



TYPE EZ-1®

Cartridge-Mounted Sealol® Metal Bellows Seal

EZ-1

- A – Insert
- B – Mating Ring
- C – O-Ring
- D – Sealol Bellows
- E – Sleeve
- F – O-Ring
- G – Centering Bushing
- H – Gland Packing
- I – Sleeve Hardware
- J – Snap Ring

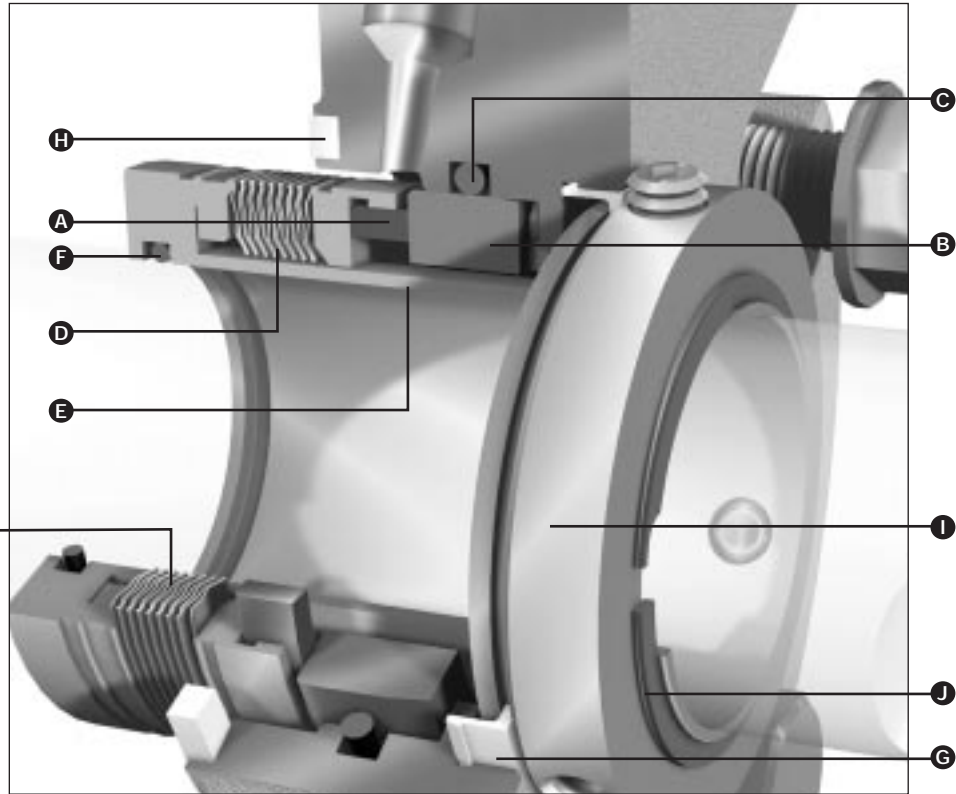

Sealol Welded Metal Bellows



Product Description

- Standard product for general-purpose applications.
- Target markets are chemicals, pulp and paper, wastewater, food processing, and power generation.
- Available with a hard-face combination for abrasive applications.
- Alloy C-276 (UNS N10276) is an optional bellows metallurgy (upon special request).

Performance Capabilities

- Temperature: -30°C to 200°C / -20°F to 400°F
- Pressure: Vacuum to 20 bar g / 300 psig
- Speed: Up to 25 m/s / 4500 fpm
- End Play/Axial Float Allowance: 0.10 mm / 0.005" F.I.M. max.
- Shaft Runout: 0.03 mm / 0.001" F.I.M. max., per inch of shaft

Design Features

- Compact and Easy to Install
- Only One Moving Part...the Bellows
- Eliminates O-Ring "Hang-Up" Problems
- Self-Cleaning Bellows Design
- No Small Springs to Clog
- Flush-Port Versatility



TYPE EZ-1

Cartridge-Mounted Seal/ Metal Bellows Seal

Piping Plans

The Type EZ-1 bellows cartridge seal provides a means of recirculating the product, flushing, or removing air from the seal chamber to extend seal life. The most popular piping plans are shown below for your reference.

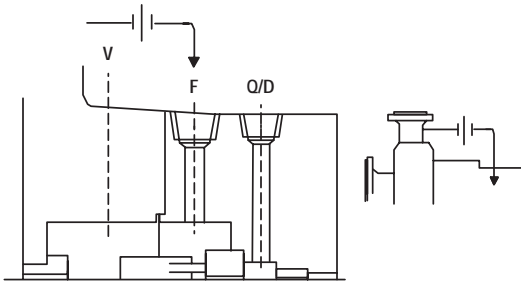

ANSI Plan 7311 (API Plan 11)

This plan requires installation of a recirculation line from the pump case discharge through an orifice to the gland flush connection. The primary purpose of this plan is to dissipate heat generated at the seal faces and/or build seal chamber pressure.

ANSI Plan 7313 (API Plan 13)

This piping plan requires the installation of a recirculation line from the gland flush connection back to the pump suction. ANSI Plan 7313 is frequently used on vertical pumps to vent vapors from the seal chamber. It is also used in applications where the seal chamber pressure is at or near discharge pressure. When utilizing this piping plan on a horizontal pump, the flush connection should be located at the top of the gland to ensure that there are no air pockets in the seal chamber.

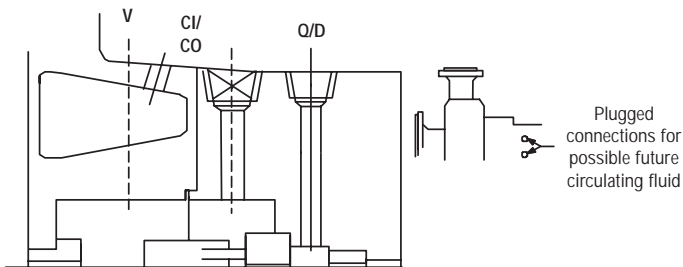
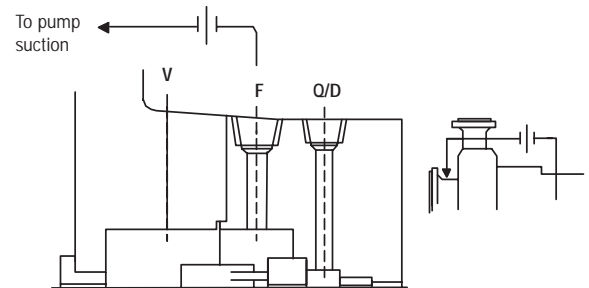

ANSI Plan 7302 (API Plan 02)

Normally specified for clean fluids, this plan calls for a dead-ended seal chamber with no circulation of flush fluid. The seal cavity may be jacketed, and a heating or cooling fluid can be circulated through the jacket. A throat bushing may be required when specified.

ANSI Plan 7332 (API Plan 32)

ANSI Plan 7332 requires the injection of a clean fluid from an external source to the seal. This flush can help to extend seal life. A close clearance throat bushing can be installed to further isolate the pumped product from the seal chamber and to minimize the amount of flush fluid required.

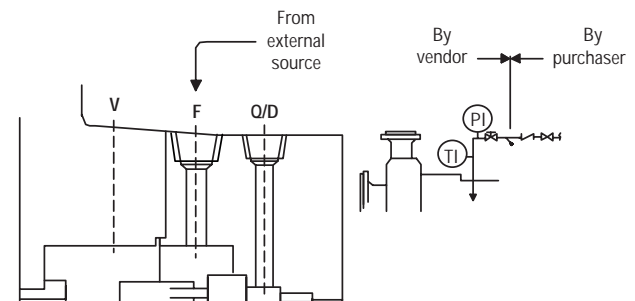

CUT LINE FOR SHORT PAGE



TYPE EZ-1

Cartridge-Mounted Sealol Metal Bellows Seal

Type EZ-1 Typical Arrangement/Dimensional Data

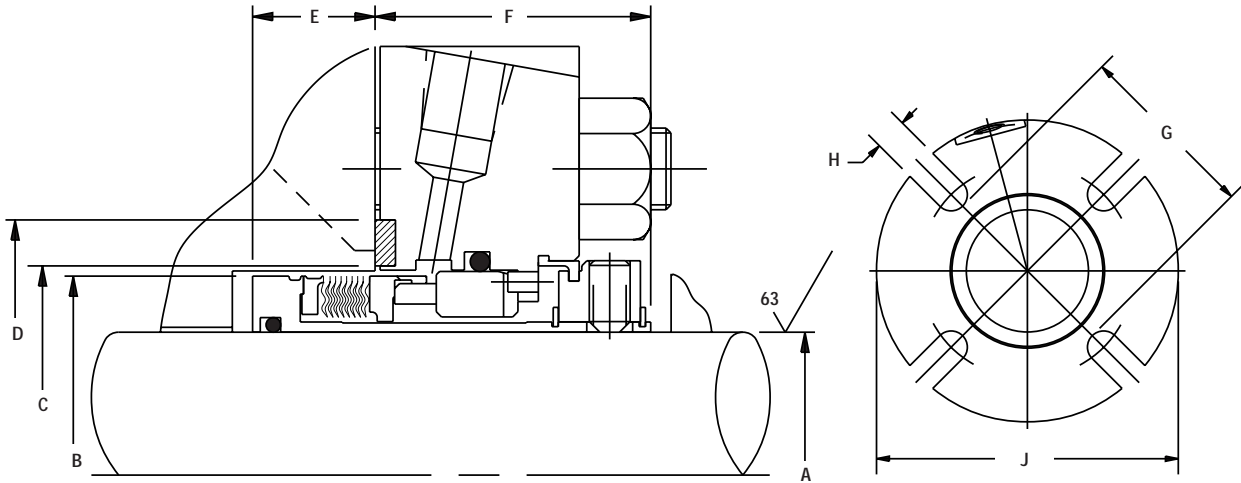

Type EZ-1 Dimensional Data (inches)

| Sealol Dash Number | Shaft Size | | | | | | | | |
|-----------------------|-------------------------------|-------|-------|-------|-------|-------|-------|-------|-------|
| | A | B | C | D | E | F | G | H | J |
| -18 | 1 ¹ / ₈ | 1.687 | 1.937 | 2.375 | 0.687 | 1.687 | 2.437 | 0.562 | 4.375 |
| -18* | 1 ¹ / ₈ | 1.687 | 1.937 | 3.250 | 0.687 | 1.687 | 3.312 | 0.437 | 4.500 |
| -22 | 1 ³ / ₈ | 1.937 | 2.062 | 2.375 | 0.687 | 1.562 | 2.437 | 0.562 | 4.375 |
| -22* | 1 ³ / ₈ | 1.937 | 2.812 | 3.250 | 0.687 | 1.562 | 3.437 | 0.500 | 5.250 |
| -24 | 1 ¹ / ₂ | 2.187 | 2.937 | 2.750 | 0.750 | 1.687 | 2.812 | 0.562 | 5.125 |
| -28 | 1 ³ / ₄ | 2.437 | 2.562 | 3.125 | 0.750 | 1.687 | 3.187 | 0.562 | 5.250 |
| -28* | 1 ³ / ₄ | 2.437 | 3.437 | 4.250 | 0.750 | 1.687 | 4.562 | 0.562 | 6.500 |
| -30 | 1 ⁷ / ₈ | 2.562 | 2.687 | 3.250 | 0.750 | 1.687 | 3.312 | 0.562 | 5.375 |
| -30* | 1 ⁷ / ₈ | 2.562 | 3.562 | 4.250 | 0.750 | 1.687 | 4.437 | 0.562 | 6.500 |
| -32 | 2 | 2.687 | 2.812 | 3.250 | 0.750 | 1.750 | 3.312 | 0.687 | 5.500 |
| -34 | 2 ¹ / ₈ | 2.812 | 2.937 | 3.500 | 0.875 | 1.687 | 3.562 | 0.687 | 5.437 |
| -40 | 2 ¹ / ₂ | 3.312 | 3.437 | 4.250 | 1.000 | 1.687 | 4.312 | 0.812 | 6.250 |
| -40* | 2 ¹ / ₂ | 3.312 | 4.375 | 5.500 | 1.000 | 1.687 | 5.625 | 0.750 | 8.000 |
| -42 | 2 ⁵ / ₈ | 3.437 | 3.562 | 4.375 | 1.187 | 1.625 | 4.437 | 0.562 | 6.500 |
| -42* | 2 ⁵ / ₈ | 3.437 | 4.375 | 5.375 | 1.187 | 1.625 | 5.437 | 0.565 | 7.000 |
| -44 | 2 ³ / ₄ | 3.625 | 3.750 | 4.500 | 1.062 | 1.625 | 4.562 | 0.750 | 7.000 |
| -48 | 3 | 3.875 | 4.000 | 4.812 | 1.125 | 1.656 | 4.875 | 0.812 | 7.750 |
| -52 | 3 ¹ / ₄ | 4.125 | 4.250 | 4.937 | 1.125 | 1.656 | 5.000 | 0.812 | 7.500 |
| -56 | 3 ¹ / ₂ | 4.375 | 4.687 | 5.625 | 1.250 | 1.656 | 5.687 | 0.812 | 8.500 |

Type EZ-1 Dimensional Data (mm)

| Sealol Dash Number | Shaft Size | | | | | | | | |
|-----------------------|------------|-------|-------|-------|------|------|-------|------|-------|
| | A | B | C | D | E | F | G | H | J |
| -028 | 28 | 42.8 | 49.2 | 60.3 | 17.4 | 42.9 | 61.9 | 14.3 | 111.1 |
| -033 | 33 | 49.2 | 52.4 | 60.3 | 17.4 | 39.7 | 61.9 | 14.3 | 106.0 |
| -035 | 35 | 49.2 | 52.4 | 60.3 | 17.4 | 39.7 | 61.9 | 14.3 | 106.0 |
| -038 | 38 | 55.5 | 58.7 | 69.8 | 19.0 | 42.9 | 71.5 | 14.3 | 130.2 |
| -040 | 40 | 58.7 | 61.9 | 71.4 | 19.1 | 42.8 | 73.0 | 14.3 | 133.4 |
| -043 | 43 | 61.9 | 65.7 | 79.4 | 19.1 | 42.9 | 81.0 | 14.3 | 133.4 |
| -045 | 45 | 61.9 | 65.1 | 79.4 | 19.1 | 42.9 | 81.0 | 14.3 | 133.4 |
| -048 | 48 | 65.1 | 68.3 | 82.6 | 19.0 | 44.5 | 84.2 | 17.4 | 139.7 |
| -050 | 50 | 68.2 | 71.4 | 82.6 | 19.0 | 44.5 | 84.2 | 17.4 | 138.0 |
| -053 | 53 | 71.4 | 74.6 | 88.9 | 22.2 | 42.9 | 90.5 | 17.4 | 138.0 |
| -055 | 55 | 71.4 | 74.6 | 88.9 | 22.2 | 42.9 | 90.5 | 17.4 | 138.0 |
| -060 | 60 | 80.9 | 84.1 | 96.8 | 25.4 | 41.3 | 98.4 | 17.4 | 158.8 |
| -065 | 65 | 87.3 | 90.5 | 109.5 | 30.2 | 41.2 | 111.1 | 17.4 | 177.8 |
| -070 | 70 | 92.1 | 95.2 | 114.3 | 27.0 | 41.2 | 115.9 | 17.5 | 190.0 |
| -075 | 75 | 98.4 | 101.6 | 122.2 | 28.5 | 42.1 | 123.8 | 20.6 | 196.9 |
| -080 | 80 | 104.8 | 108.0 | 125.4 | 28.5 | 42.1 | 127.0 | 19.1 | 190.0 |
| -085 | 85 | 108.0 | 111.1 | 125.4 | 31.7 | 42.1 | 127.0 | 19.1 | 203.2 |
| -100 | 100 | 128.6 | 131.8 | 154.0 | 34.9 | 42.1 | 155.6 | 22.2 | 228.6 |

*Enlarged seal chamber version.



TYPE EZ-1

Cartridge-Mounted Seal/ Metal Bellows Seal

Pressure Ratings

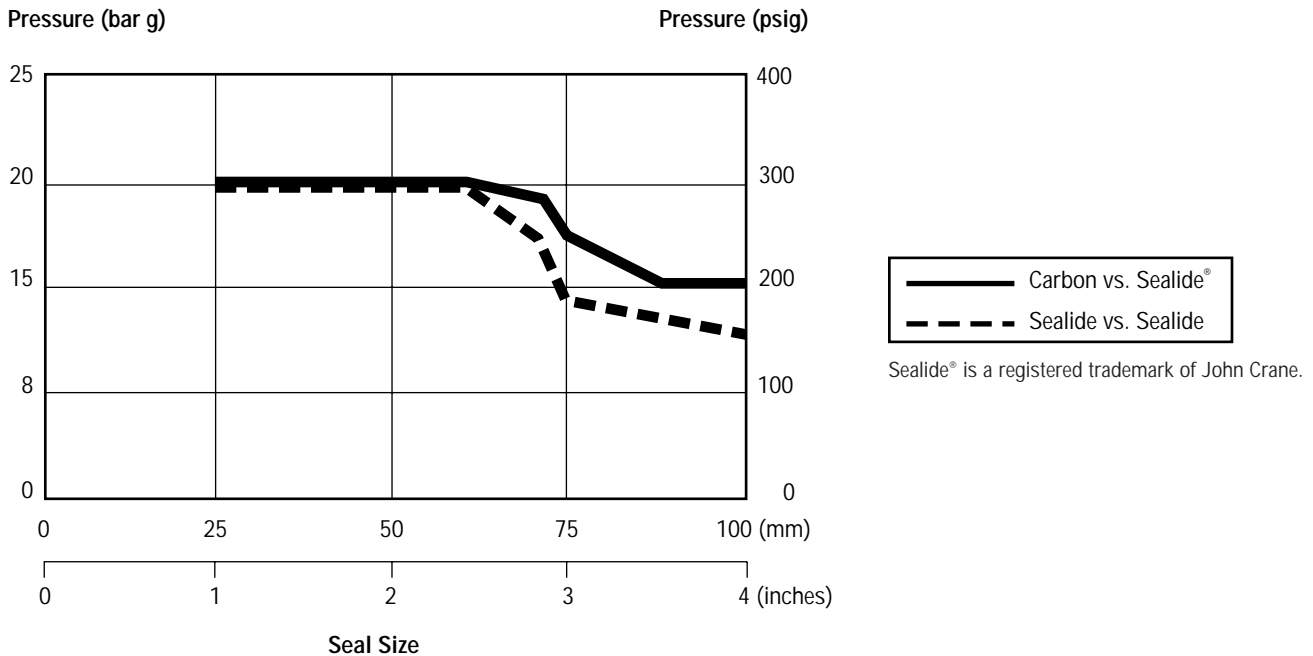

To determine the maximum pressure for the size of Type EZ-1 seal required, multiply the maximum pressure by the factors in the chart below to obtain the maximum operating pressure. Consult John Crane Engineering for applications outside these limits.

Multiplier Factors

| | Selection Considerations | Multiplier Factor | |
|---|--|----------------------------|----------------------------------|
| | | Carbon vs. SiC | SiC vs. SiC |
| Speed | Between 400 and 3600 rpm Below 400 or above 3600 rpm | x 1.00 (see Note 1) | x 1.00 (see Note 1) |
| Sealed Fluid Lubricity | Petrol/Gasoline, Kerosene, or Better Water and Aqueous Solutions (<80°C/176°F) Light Hydrocarbons (see Note 2) | x 1.00 x 0.75 x 0.60 | x 1.00 x 0.75 (see Note 3) |
| Sealed Fluid Temperature (see Note 4) | Up to 80°C/175°F Up to 150°C/300°F Up to 200°C/400°F | x 1.00 x 0.85 x 0.70 | x 1.00 x 1.00 x 1.00 |

Notes:

1. Contact John Crane Engineering for more information.
2. Specific gravity ≥ 0.6 and ratio of sealed pressure to vapor pressure > 1.5 .
3. More details regarding the fluid and the operating conditions are required.
4. Temperature at the seal faces includes effects of flush, quench, and cooling.

Example for Determining Dynamic Pressure Rating:

Seal: 50mm/2" Type EZ-1 Product: Water Face Materials: Carbon vs. Sealide
 Temperature: 21°C/70°F Speed: 3000 rpm

Find the maximum operating pressure for the applications.

$$20 \text{ bar g}/300 \text{ psig} \times 1.00 \times 0.75 \times 1.00 = 15 \text{ bar g}/225 \text{ psig.}$$

At 3000 rpm with the service conditions noted, a 50mm/2" diameter Type EZ-1 seal has a maximum operating limit of 15 bar g/225 psig.



TYPE EZ-1

Cartridge-Mounted Seal/Metal Bellows Seal

Materials of Construction

| SEAL COMPONENTS | MATERIALS | |
|--|---|------------------------------------|
| | Description | Options |
| Insert | Carbon | Sealide (Sintered Silicon Carbide) |
| Mating Ring | Sealide (Sintered Silicon Carbide) | — |
| Sleeve Sleeve Hardware Gland Centering Bushing Snap Ring Set Screws | 316 L Stainless Steel 303 Stainless Steel 316 Stainless Steel PTFE 302 Stainless Steel 316 Stainless Steel or Hardened Steel | — |
| Bellows | Alloy 20 (UNS N08020) | Alloy C-276 (UNS N10276) |
| Mating Ring O-Ring | PTFE-Encapsulated Fluorocarbon | — |
| Sleeve O-Ring | Fluorocarbon PTFE-Encapsulated Fluorocarbon Ethylene Propylene | — |

CUT LINE FOR SHORT PAGE

Seal/Welded Metal Bellows

Seal Design Features

- Optimum 45° Tilt Angle
- Three-Sweep Radius
- Nesting Ripple Plate Design
- Static Secondary Seal
- Light Spring Loads

Seal Bellows Benefits

- Uniform Plate Rigidity and Stress Distribution
- Enhanced Fatigue Strength
- Self-Cleaning Through Centrifugal Action
- Pressure Balanced by Design
- Less Heat
- Low Power Consumption

Recommended Flush Flow Rates

| SEAL SIZE | FLOW RATE |
|-----------------------|-------------------------------|
| 25 to 50mm/1" to 2" | 4 to 6 Liter/Min./1 to 1½ GPM |
| 53 to 76mm/2¼" to 3" | 6 to 8 Liter/Min./1½ to 2 GPM |
| 79 to 102mm/3⅛" to 4" | 4 to 6 Liter/Min./2 to 3 GPM |



John Crane

North and Latin Americas
Morton Grove, Illinois USA

Tel: 1-847-967-2400
Fax: 1-847-967-3915
1-800-SEALING

Europe, Middle East, Africa
Slough, UK

Tel: 44-1753-224000
Fax: 44-1753-224224

Asia Pacific
Singapore

Tel: 65-222-9161
Fax: 65-223-5035



For your nearest John Crane facility, please contact one of the locations above.

If the products featured will be used in a potentially dangerous and/or hazardous process, your John Crane representative should be consulted prior to their selection and use. In the interest of continuous development, John Crane Companies reserve the right to alter designs and specifications without prior notice. It is dangerous to smoke while handling products made from PTFE. Old and new PTFE products must not be incinerated.