



TYPE RREP

High Duty Cartridge O-Ring Seal

RREP

- A – Face/Primary Ring
- B – Seat/Mating Ring
- C – Anti-Extrusion Rings
- D – Spring
- E – Sleeve
- F – Seal Ring Carrier

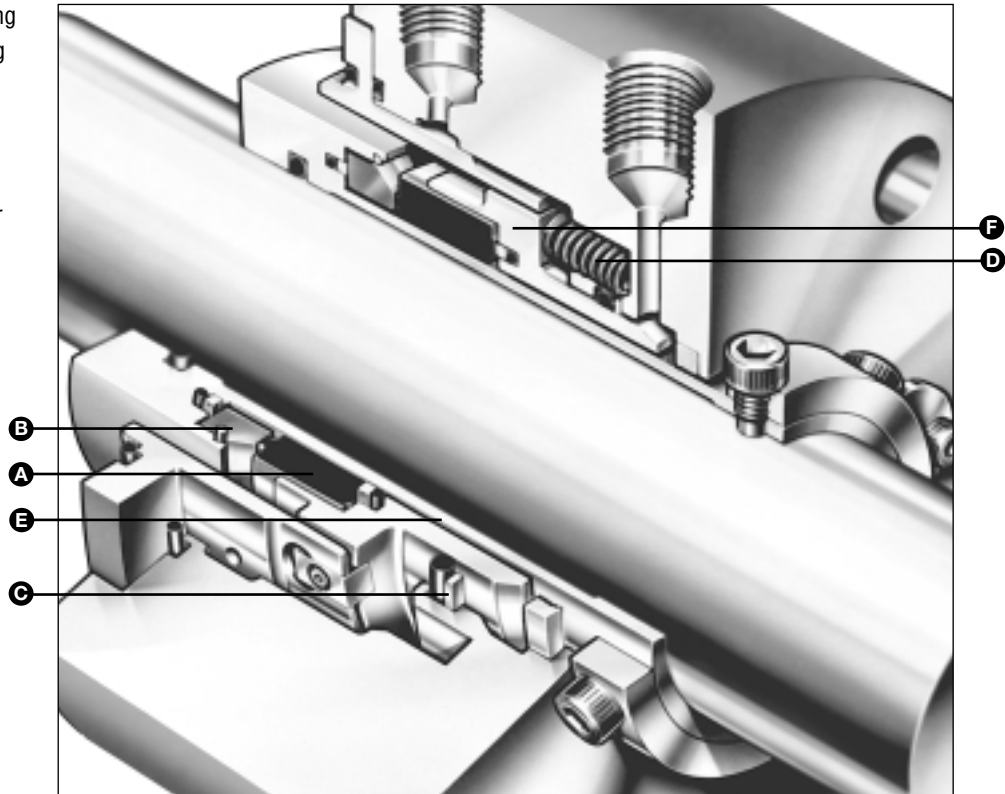

Product Description

The Type RREP Cartridge O-Ring Seal, available in single and dual arrangements, is designed for high pressure and high speed applications.

- The RREP can be used for hydrocarbons, sour gas, crude oil, boiler feed water, propane and butane services.
- It is ideally suited to use on offshore, pipeline and injection duties, and power generation plants.
- The stationary multi-spring design maintains a stable, fluid film even at extremes of speed and pressure.
- Complies with API 610 and can be supplied to meet other international standards such as NACE MR-01-075.
- The axially compact design allows for use on pumps with close bearing centers.

Design Features

- Standard Multi-Point Injection with Option of Through Spring Flush on Dirty Products
- Available in Double, Tandem and Dry Tandem Arrangements
- FEA Optimized Seal Rings
- Hard-Faced Seal Ring Carrier
- Monel® Anti-Rotation Keys or Pins
- PTFE/PEEK Anti-Extrusion Rings

Monel is a registered trademark of Inco Alloys International, Inc.

Performance Capabilities

- Temperature:
-40°C to 315°C/-40°F to 600°F
- Pressure:
Vacuum to 175 bar g/2540 psig
- Speed:
Up to 55 m/s/11,000 fpm



TYPE RREP

High Duty Cartridge O-Ring Seal

Type RREP Typical Arrangement/Dimensional Data

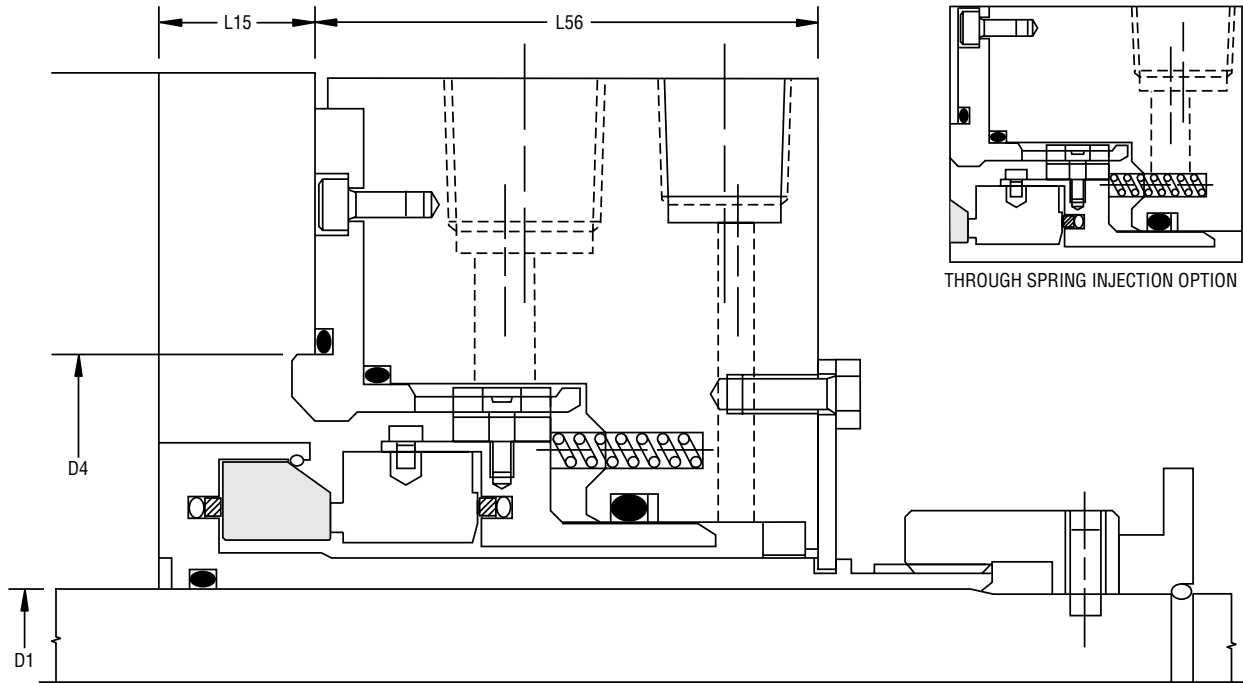

Multi-Point injection design shown.

Type RREP Dimensional Data (mm)

Seal Size Code (mm)	Max. Shaft Diameter		Multi-Point Injection		Through-Spring Circulation	
	D1	D4	L15	L56	L15	L56
0400	33.0	71.00	0	92.0	15	77.0
0450	38.0	75.50	0	92.0	15	77.0
0500	43.0	83.50	0	95.5	15	80.5
0560	49.0	88.50	0	95.5	15	80.5
0600	54.0	95.50	0	95.5	15	80.5
0630	57.0	97.50	8	97.5	23	82.5
0670	61.0	102.00	8	97.5	23	82.5
0700	64.0	107.00	8	97.5	23	82.5
0750	68.0	111.50	11	97.5	26	82.5
0800	74.0	116.50	11	97.5	26	82.5
0850	77.0	123.00	10	98.5	26	82.5
0900	83.0	127.50	10	98.5	26	82.5
0950	87.0	133.50	10	98.5	26	82.5
1000	92.0	140.50	10	98.5	26	82.5
1050	98.0	144.50	10	98.5	26	82.5
1100	102.0	152.50	10	98.5	26	82.5
1150	108.0	159.00	10	98.5	26	82.5
1200	111.0	162.50	10	98.5	26	82.5
1250	120.0	173.00	10	98.5	26	85.5
1300	123.0	176.00	15	106.5	36	85.5
1350	128.0	180.50	15	106.5	36	85.5
1400	133.0	186.00	15	106.5	36	85.5
1450	138.0	193.00	15	106.5	36	85.5
1500	145.0	206.50	15	106.5	36	85.5
1600	156.0	216.50	15	106.5	36	85.5
1700	165.0	226.50	15	106.5	36	85.5
1800	175.0	240.50	15	106.5	36	85.5
1900	186.0	247.50	15	111.5	31	85.5
2000	197.0	261.35	10	111.5	31	90.5

Type RREP Dimensional Data (inches)

Seal Size Code (mm)	Max. Shaft Diameter		Multi-Point Injection		Through-Spring Circulation	
	D1	D4	L15	L56	L15	L56
0400	1.29	2.79	0.00	3.62	0.59	3.03
0450	1.50	2.97	0.00	3.62	0.59	3.03
0500	1.69	3.28	0.00	3.75	0.59	3.16
0560	1.92	3.48	0.00	3.75	0.59	3.16
0600	2.12	3.76	0.00	3.75	0.59	3.16
0630	2.24	3.84	0.31	3.83	0.91	3.24
0670	2.40	4.00	0.31	3.83	0.91	3.24
0700	2.51	4.21	0.31	3.83	0.91	3.24
0750	2.68	4.39	0.43	3.83	1.02	3.24
0800	2.91	4.59	0.43	3.83	1.02	3.24
0850	3.03	4.84	0.39	3.88	1.02	3.24
0900	3.26	5.02	0.39	3.88	1.02	3.24
0950	3.43	5.25	0.39	3.88	1.02	3.24
1000	3.62	5.53	0.39	3.88	1.02	3.24
1050	3.86	5.69	0.39	3.88	1.02	3.24
1100	4.01	6.00	0.39	3.88	1.02	3.24
1150	4.25	6.25	0.39	3.88	1.02	3.24
1200	4.37	6.39	0.39	3.88	1.02	3.24
1250	4.72	6.81	0.39	3.88	1.02	3.37
1300	4.84	6.93	0.59	4.19	1.41	3.37
1350	5.03	7.11	0.59	4.19	1.41	3.37
1400	5.23	7.32	0.59	4.19	1.41	3.37
1450	5.43	7.60	0.59	4.19	1.41	3.37
1500	5.71	8.12	0.59	4.19	1.41	3.37
1600	6.14	8.52	0.59	4.19	1.41	3.37
1700	6.49	8.92	0.59	4.19	1.41	3.37
1800	6.89	9.46	0.59	4.19	1.41	3.37
1900	7.32	9.74	0.59	4.38	1.22	3.37
2000	7.76	10.29	0.39	4.38	1.22	3.56



TYPE RREP

High Duty Cartridge O-Ring Seal

Type R RTP Typical Arrangement

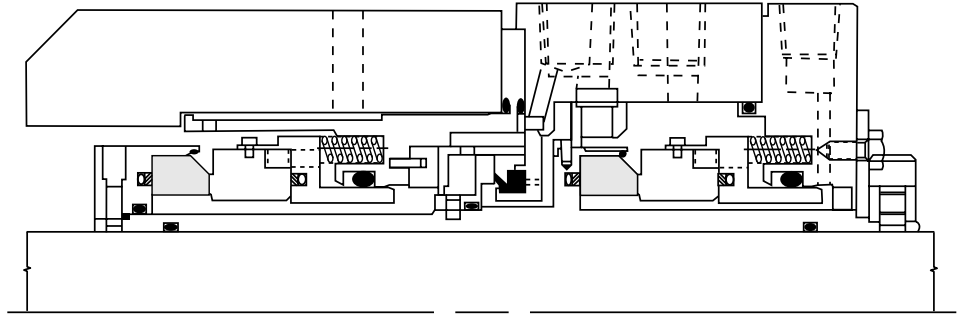

The dual, unpressurized (tandem) arrangement consists of two seals in series. The inner seal operates on pumped fluid and the outer seal normally operates on a low pressure buffer liquid. The outer seal is designed to provide a full-duty backup service.

Type R RCP Typical Arrangement

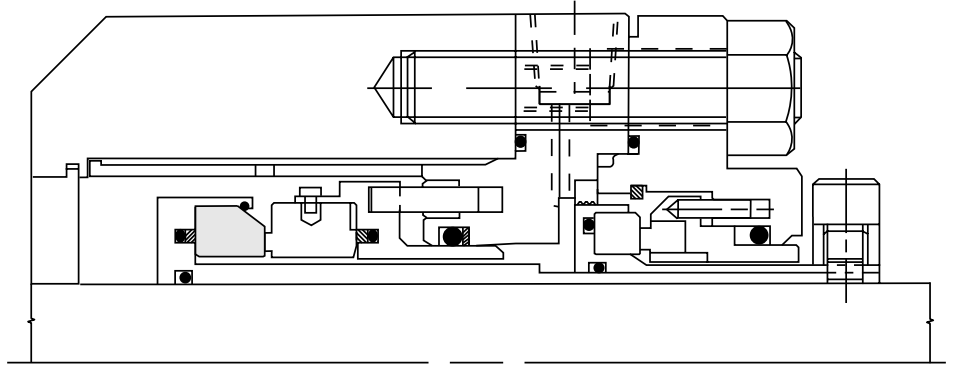

The dry tandem arrangement uses the high duty version of the SBOP backup seal to provide operational security without the expense of a liquid buffer system. In the event of failure of the inner seal, the SBOP will prevent loss of the pumped fluid to the atmosphere. This can be detected by use of a pressure switch.

Type R RDP Typical Arrangement

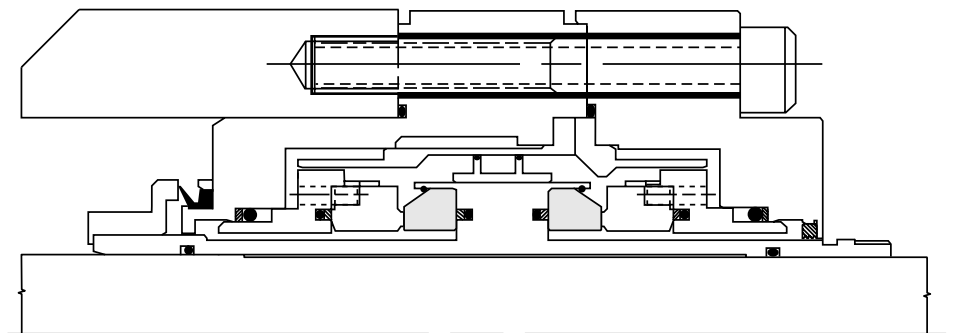

This dual pressurized (double) arrangement consists of two seals face to face and operating on a barrier liquid. Any leakage from the inner seal will be of barrier fluid into the pumped product. The inner seal includes a double balance line for reverse pressure protection.

NOTE: The above seals are normally designed to suit a particular machine or application. For approximate installation dimensions, consult John Crane.



TYPE RREP

High Duty Cartridge O-Ring Seal

Multiplier Factors

	Selection Considerations	Multiplier Factor
Sealed Fluid Lubricity	Petrol/Gasoline, Kerosene, or Better Flashing Hydrocarbons* (Specific Gravity ≤ 0.65)	x 1.00 x 0.60
Sealed Fluid Temperature (for carbon only)	Up to 80°C/175°F From 80°C to 120°C/175°F to 250°F From 120°C to 180°C/250°F to 355°F Above 180°C/350°F	x 1.00 x 0.90 x 0.80 x 0.65
Speed	Up to 3600 rpm Above 3600 rpm**	x 1.00 x 3600/ new speed

* The ratio of sealed pressure to vapor pressure must be greater than 1.5, otherwise consult John Crane. If the specific gravity is less than 0.60, consult John Crane.

** Up to maximum speed of 55 m/s (11,000 fpm).

Example for Determining Pressure Rating Limits:

Seal: 76.2mm/3" diameter Type RREP

Product: Crude Oil

Face Materials: Silicon Carbide vs. Tungsten Carbide

Operating Temperature: 90°C/194°F

Pressure: 80 bar g/1160 psig

Speed: 4500 rev./min.

Using the Pressure Rating Limits graph, the maximum pressure would be 175 bar g/2540 psig.

From the Multiplier Factors chart, apply the multipliers for the specific service requirements to determine the maximum operating pressure for the application.

$$175 \text{ bar}/2540 \text{ psi} \times 1.00 \times 3600/4500 = 140 \text{ bar}/2030 \text{ psi}$$

The maximum operating pressure for this 76.2mm/3" Type RREP is 140 bar/2030 psi.

Basic Pressure Rating (Hydrocarbons)

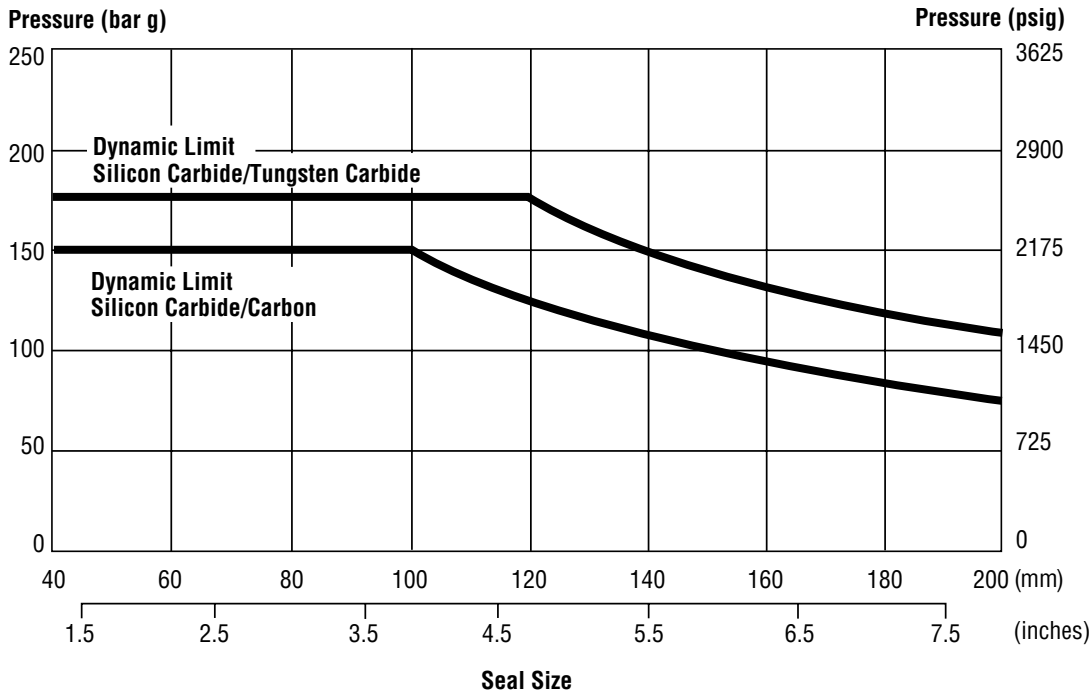

The Basic Pressure Rating is for a standard seal, as shown in the typical arrangement, when installed according to the criteria given in this data sheet and generally accepted industrial practices.

The Basic Pressure Rating assumes stable operation at 3600 rpm in a clean, cool, lubricating, non-volatile liquid with an adequate flush rate. When used with the multiplier factors, the Basic Pressure Rating can be adjusted to provide a conservative estimate of the dynamic pressure rating. For process services outside this range or a more accurate assessment of the dynamic pressure rating, contact John Crane for more information.

CUT LINE FOR SHORT PAGE



TYPE RREP

High Duty Cartridge O-Ring Seal

Multiplier Factors (Aqueous Solutions)

	Selection Considerations	Multiplier Factor
Sealed Fluid Temperature (for carbon only)	Up to 80°C/175°F	x 1.00
	From 80°C to 120°C/175°F to 250°F	x 0.90
	From 120°C to 180°C/250°F to 355°F	x 0.80
	Above 180°C/350°F	x 0.65
Speed	Up to 3600 rpm Above 3600 rpm*	x 1.00 x 3600/ new speed

*Up to maximum speed of 55 m/s (11,000 fpm).

Basic Pressure Rating (Water and Aqueous Solutions)

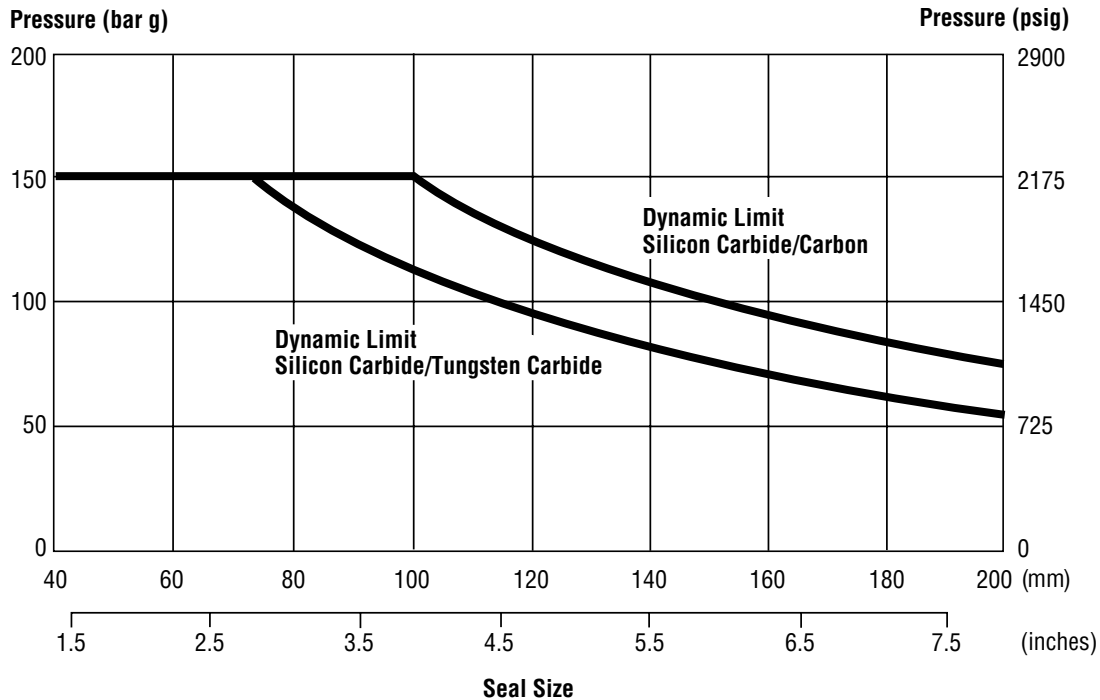

The Basic Pressure Rating is for a standard seal, as shown in the typical arrangement, when installed according to the criteria given in this data sheet and generally accepted industrial practices.

The Basic Pressure Rating assumes stable operation at 3600 rpm in a clean, cool, lubricating, non-volatile liquid with an adequate flush rate. When used with the multiplier factors, the Basic Pressure Rating can be adjusted to provide a conservative estimate of the dynamic pressure rating. For process services outside this range or a more accurate assessment of the dynamic pressure rating, contact John Crane for more information.

CUT LINE FOR SHORT PAGE



TYPE RREP

High Duty Cartridge O-Ring Seal

Materials of Construction

SEAL COMPONENTS	MATERIALS	
	Description	Options
Face/Primary Ring	Carbon Graphite	Nickel Bound Tungsten Carbide Silicon/Graphite Composite
Seat/Mating Ring	Silicon Carbide	—
Secondary O-Rings	Ethylene Propylene Fluorocarbon Nitrile Perfluoroelastomer	PTFE/Spring Energized PTFE* High Temperature Polymer*
Anti-Extrusion Ring	PTFE/PEEK	—
Springs	Inconel®	Alloy C-276
Metal Components	316 Stainless Steel	Duplex Stainless Steel (UNS S31803) Materials to NACE MR-01-75

*Refer to John Crane
Inconel is a registered trademark of Inco Alloys International, Inc.

Hydrostatic/Static Pressure Limits

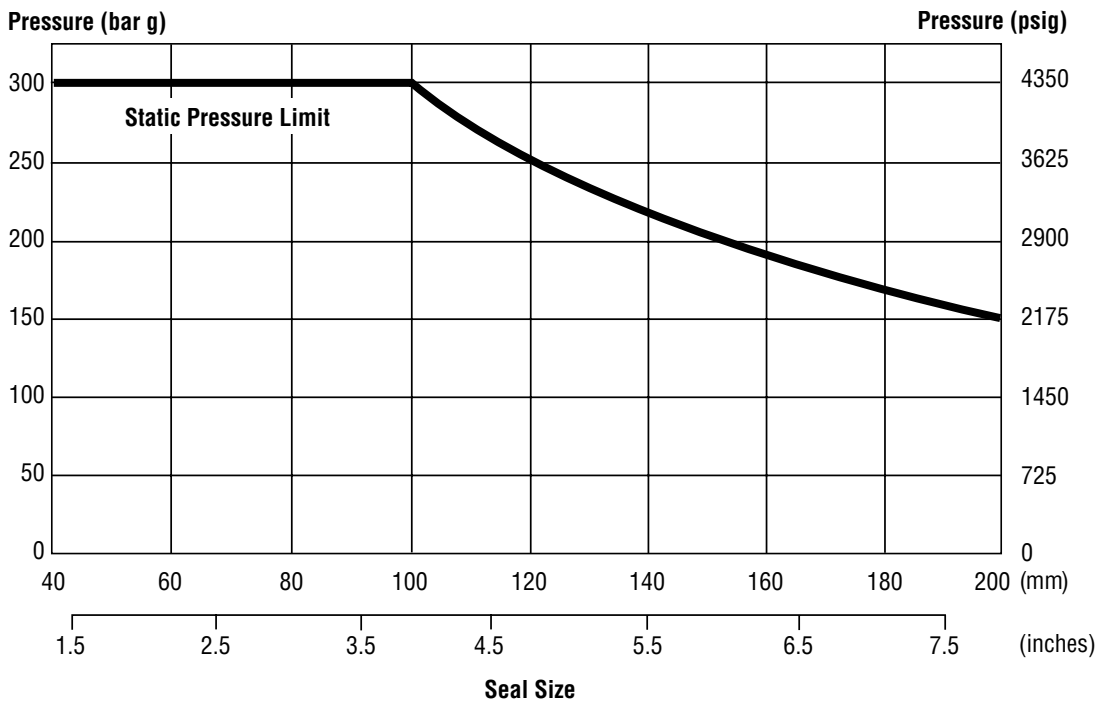

North America
Morton Grove, Illinois USA

Tel: 1-847-967-2400
Fax: 1-847-967-3915

1-800-SEALING

Europe, Middle East, Africa
Slough, UK

Tel: 44-1753-224000
Fax: 44-1753-224224

Latin America
São Paulo, Brazil

Tel: 55-11-3049-9900
Fax: 55-11-3849-8270

Asia Pacific
Singapore

Tel: 65-222-9161
Fax: 65-223-5035



For your nearest John Crane facility, please contact one of the locations above.

If the products featured will be used in a potentially dangerous and/or hazardous process, your John Crane representative should be consulted prior to their selection and use. In the interest of continuous development, John Crane Companies reserve the right to alter designs and specifications without prior notice. It is dangerous to smoke while handling products made from PTFE. Old and new PTFE products must not be incinerated.