

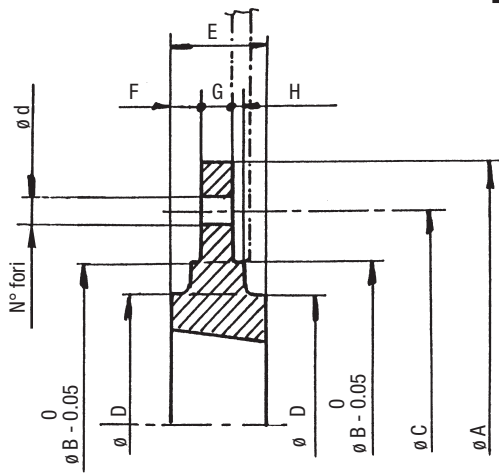

MOZZI SMONTABILI PER BUSSOLA CONICA



GHISA											
TIPO	BUSSOLA	ØA	ØB	ØC	ØD	E	F	G	H	N. FORI	Ød
MSM T.L. Ø 120	1210	120	80	100	70	25	9	7.5	2.5	6	7.5
MSM T.L. Ø 130	1610	130	90	110	80	25	9	7.5	2.5	6	7.5
MSM T.L. Ø 145	2012	145	115	125	95	32	12	9.5	2.5	6	9.5
MSM T.L. Ø 185	2517	185	130	155	115	45	19	12.5	2.5	6	11.5
MSM T.L. Ø 220	3020	220	165	190	145	51	19	12.5	2.5	6	13.5

GHISA - (*) Acciaio											
TIPO	BUSSOLA	ØA	ØB	ØC	ØD	E	F	G	H	N. FORI	Ød
MSM T.L. Ø 180	1210	180	90	135	75	25	9.25	6.5	2.5	6	7.5
MSM T.L. Ø 200	1615	200	110	150	85	38	15.3	7.5	2.5	6	7.5
MSM T.L. Ø 270	2012	270	140	190	110	32	11.8	8.5	2.5	6	9.5
MSM T.L. Ø 340	2517	340	170	240	125	45	17.8	9.5	2.5	8	11.5
MSM T.L. Ø 430	3020	430	220	300	160	51	18.8	13.5	2.5	8	13.5
(*)MSM T.L. Ø 485	3020	485	250	340	160	51	18.8	13.5	2.5	8	13.5