

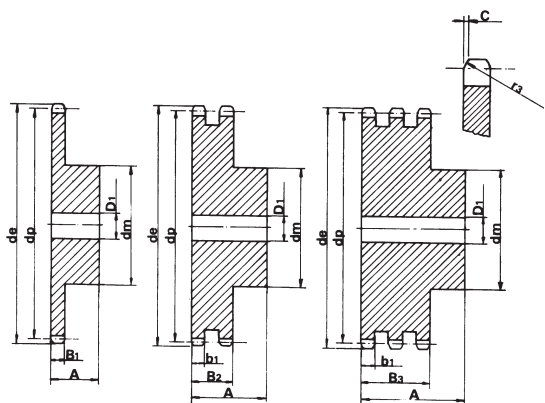

Passo 3/8" x 3/16"

per catene a rulli secondo
DIN 8188 - ISO/R 606 - ANSI B 29.1



PIGNONE

RAGGIO DENTE r_3	10	mm
LARGHEZZA RAGGIO C	1.2	mm
LARGHEZZA DENTE B_1	4.4	mm
LARGHEZZA DENTE b_1	4.3	mm
LARGHEZZA DENTE B_2	14.4	mm

CATENA

PASSO	9.525	mm
LARGHEZZA INTERNA	4.77	mm
RULLO \emptyset	5.08	mm

MATERIALE: C 45 UNI 7845 PIGNONI

PIGNONI ASA 35

PIGNONI SEMPLICI DOPPI

Z	d_e	d_p	d_m	D_1	A	d_m	D_1	A
10	35.70	30.82	20	8	22			
11	38.69	33.80	22	8	25			
12	41.68	36.80	25	8	25			
13	44.68	39.80	28	10	25	28	10	25
14	47.68	42.80	31	10	25	31	10	25
15	50.69	45.81	34	10	25	34	10	25
16	53.70	48.82	37	10	28	37	12	30
17	56.72	51.83	38	10	28	40	12	30
18	59.73	54.85	38	10	28	43	12	30
19	62.75	57.87	46	10	28	46	12	30
20	65.77	60.89	46	10	28	49	12	30
21	68.79	63.91	46	10	28	52	12	30
22	71.81	66.93	52	12	28	55	12	30
23	74.83	69.95	52	12	28	58	12	30
24	77.85	72.97	52	12	28	61	12	30
25	80.88	76.00	58	12	28	64	12	30
26	83.90	79.02	58	12	28	67	12	30
27	86.93	82.04	58	12	28	70	12	30
28	89.95	85.07	60	12	28	73	12	30
30	96.00	91.12	60	12	28			

Passo 1/2" x 5/16"

per catene a rulli secondo
DIN 8188 - ISO/R 606 - ANSI B 29.1

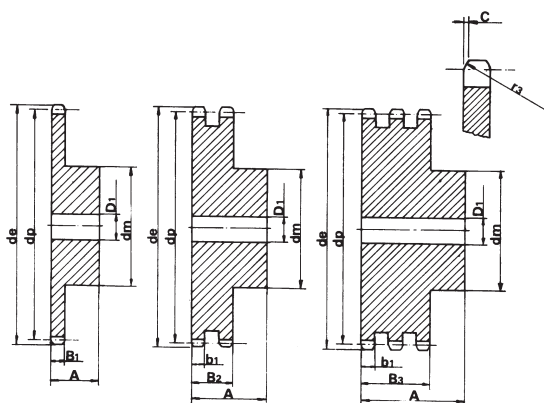

PIGNONE

RAGGIO DENTE r_3	13.5	mm
LARGHEZZA RAGGIO C	1.6	mm
LARGHEZZA DENTE B_1	7.4	mm
LARGHEZZA DENTE b_1	7.2	mm
LARGHEZZA DENTE B_2	21.6	mm
LARGHEZZA DENTE B_3	36	mm

CATENA

PASSO	12.7	mm
LARGHEZZA INTERNA	7.94	mm
RULLO \emptyset	7.94	mm

PIGNONI ASA 40

PIGNONI SEMPLICI DOPPI TRIPLI

Z	d_e	d_p	d_m	D_1	A	d_m	D_1	A	d_m	D_1	A
10	47.66	41.10	26	10	25						
11	51.64	45.08	29	10	25						
12	55.63	49.07	35	10	28				35	14	50
13	59.63	53.07	35	10	28	38	12	35	38	14	50
14	63.63	57.07	35	10	28	42	12	35	42	14	50
15	67.64	61.08	46	10	28	46	12	35	46	14	50
16	71.66	65.10	48	10	28	50	14	35	50	16	50
17	75.68	69.12	48	10	28	54	14	35	54	16	50
18	79.70	73.14	58	12	28	58	14	35	58	16	50
19	83.72	77.16	60	12	28	62	14	35	62	16	50
20	87.74	81.18	60	12	28	66	14	35	66	16	50
21	91.77	85.21	65	12	28	70	16	40	70	20	55
22	95.80	89.24	65	12	28	70	16	40	70	20	55
23	99.83	93.27	65	12	28	70	16	40	70	20	55
24	103.86	97.30	70	14	28	75	16	40	75	20	55
25	107.89	101.33	70	14	28	80	16	40	80	20	55
26	111.92	105.36	70	14	28	85	20	40	85	20	55
27	115.96	109.40	70	16	30	85	20	40	85	20	55
28	119.99	113.43	70	16	30	90	20	40	90	20	55
30	128.06	121.50	80	16	30	100	20	40			
32	136.13	129.57	80	16	30						
35	148.24	141.68	90	16	30						
36	152.28	145.72	90	16	30						
38	160.35	153.79	90	16	35						
40	168.43	161.87	90	16	35						



Passo 5/8" x 3/8"

per catene a rulli secondo
DIN 8188 - ISO/R 606 - ANSI B 29.1

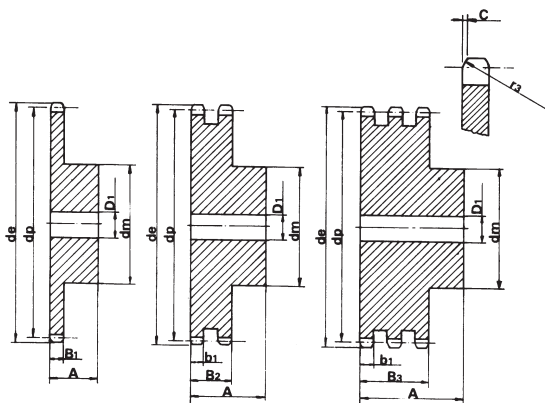

PIGNONE

RAGGIO DENTE r_3	17	mm
LARGHEZZA RAGGIO C	2	mm
LARGHEZZA DENTE B_1	9	mm
LARGHEZZA DENTE b_1	8.8	mm
LARGHEZZA DENTE B_2	26.9	mm
LARGHEZZA DENTE B_3	45	mm

CATENA

PASSO	15.875	mm
LARGHEZZA INTERNA	9.52	mm
RULLO \emptyset	10.16	mm

MATERIALE: C 45 UNI 7845

PIGNONI ASA 50

Z	SEMPLICI			DOPPI			TRIPLI		
	d_e	d_p	d_m D ₁ A	d_m D ₁ A	d_m D ₁ A				
8	47.0	41.48	25 10 25						
9	52.6	46.42	30 10 25						
10	57.5	51.37	35 10 25						
11	63.0	56.34	37 12 30						
12	68.0	61.34	42 12 30			44 16 55			
13	73.0	66.32	47 12 30	49 14 40		49 16 55			
14	78.0	71.34	52 12 30	54 14 40		54 16 55			
15	83.0	76.36	57 12 30	59 14 40		59 16 55			
16	88.0	81.37	60 12 30	64 16 45		64 16 60			
17	93.0	86.39	60 12 30	69 16 45		69 16 60			
18	98.3	91.42	70 14 30	74 16 45		74 16 60			
19	103.3	96.45	70 14 30	79 16 45		79 16 60			
20	108.4	101.49	75 14 30	84 16 45		84 16 60			
21	113.4	106.52	75 16 30	85 16 45		85 20 60			
22	118.0	111.55	80 16 30	90 16 45		90 20 60			
23	123.4	116.58	80 16 30	95 16 45		95 20 60			
24	128.3	121.62	80 16 30	100 16 45		100 20 60			
25	134.0	126.66	80 16 30	105 16 45		105 20 60			
26	139.0	131.70	85 20 35			110 20 60			
27	144.0	136.75	85 20 35			110 20 60			
28	148.7	141.78	90 20 35			115 20 60			
29	153.8	146.83	90 20 35						
30	158.8	151.87	90 20 35						
31	163.9	156.92	95 20 35						
32	168.9	161.95	95 20 35						
33	174.5	167.00	95 20 35						
34	179.0	172.05	95 20 35						
35	184.1	177.10	95 20 35						
36	189.1	182.15	100 20 35						
37	194.2	187.20	100 20 35						
38	199.2	192.24	100 20 35						
39	204.2	197.29	100 20 35						
40	209.3	202.34	100 20 35						

Passo 3/4" x 1/2"

per catene a rulli secondo
DIN 8188 - ISO/R 606 - ANSI B 29.1

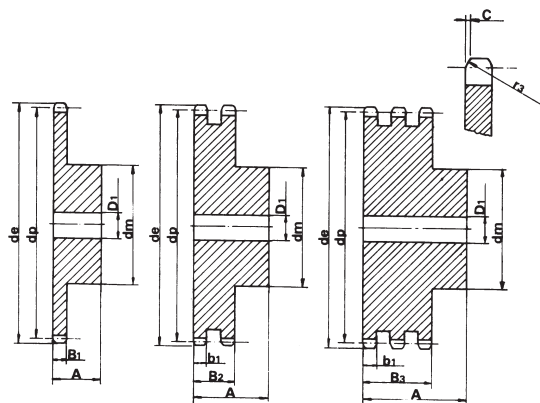

PIGNONE

RAGGIO DENTE r_3	20	mm
LARGHEZZA RAGGIO C	2.4	mm
LARGHEZZA DENTE B_1	12.0	mm
LARGHEZZA DENTE b_1	11.8	mm
LARGHEZZA DENTE B_2	34.6	mm
LARGHEZZA DENTE B_3	57.4	mm

CATENA

PASSO	19.05	mm
LARGHEZZA INTERNA	12.7	mm
RULLO \emptyset	11.91	mm

MATERIALE: C 45 UNI 7845

PIGNONI ASA 60

Z	SEMPLICI			DOPPI			TRIPLI		
	d_e	d_p	d_m D ₁ A	d_m D ₁ A	d_m D ₁ A				
10	71.54	61.64	42 12 30	42 12 45					
11	77.51	67.61	45 12 30	47 16 50					
12	83.49	73.61	45 12 30	53 16 50	53 20 70				
13	89.49	79.59	60 14 35	59 16 50	59 20 70				
14	95.50	85.61	60 14 35	65 16 50	65 20 70				
15	101.52	91.63	60 14 35	71 16 50	71 20 70				
16	107.54	97.65	75 16 35	77 20 50	77 20 70				
17	113.56	103.67	75 16 35	83 20 50	83 20 70				
18	119.59	109.71	75 16 35	89 20 50	89 20 70				
19	125.63	115.75	80 16 35	95 20 50	95 20 70				
20	131.67	121.78	80 16 35	100 20 50	100 20 70				
21	137.71	127.82	80 16 35	100 20 50	100 20 70				
22	143.75	133.86	90 20 40	100 20 50	100 20 70				
23	149.79	139.90	90 20 40	110 20 50	110 20 70				
24	155.84	145.94	90 20 40	110 20 50	110 20 70				
25	161.88	152.00	90 20 40	120 20 50	120 20 70				
26	167.93	158.04	90 20 40	120 20 50					
27	173.98	164.09	90 20 40	120 20 50					
28	180.03	170.13	95 20 40	120 20 50					
30	192.14	182.25	95 20 40	120 20 50					



Passo 1" x 5/8"

per catene a rulli secondo
DIN 8188 - ISO/R 606 - ANSI B 29.1

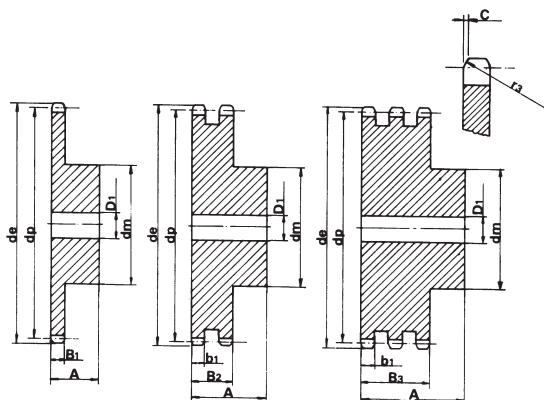

PIGNONE

RAGGIO DENTE r_3	27	mm
LARGHEZZA RAGGIO C	3.2	mm
LARGHEZZA DENTE B_1	15.0	mm
LARGHEZZA DENTE b_1	14.7	mm
LARGHEZZA DENTE B_2	44.0	mm
LARGHEZZA DENTE B_3	73.3	mm

CATENA

PASSO	25.4	mm
LARGHEZZA INTERNA	15.88	mm
RULLO \emptyset	15.88	mm

MATERIALE: C 45 UNI 7845

PIGNONI ASA 80

Z	SEMPLICI			DOPPI			TRIPLI		
	d_e	d_p	d_m D ₁ A	d_m D ₁ A	d_m D ₁ A				
8	79.49	66.37	42 16 35						
9	87.38	74.27	50 16 35						
10	95.32	82.19	55 16 35						
11	103.28	90.14	61 16 40						
12	111.26	98.14	69 16 40	72 20 70	72 25 100				
13	119.26	106.12	78 16 40	78 20 70	78 25 100				
14	127.27	114.15	84 16 40	86 20 70	86 25 100				
15	135.29	122.17	92 16 40	94 20 70	94 25 100				
16	143.32	130.20	100 20 45	102 20 70	102 30 100				
17	151.35	138.22	100 20 45	110 20 70	110 30 100				
18	159.39	146.28	100 20 45	118 20 70	118 30 100				
19	167.44	154.33	100 20 45	126 20 70	126 30 100				
20	175.49	162.38	100 20 45	130 20 70	130 30 100				
21	183.54	170.43	110 20 50	130 25 70					
22	191.60	178.48	110 20 50						
23	199.66	186.53	110 20 50						
24	207.72	194.59	110 20 50						
25	215.78	202.66	110 20 50						
26	223.84	210.72	120 20 50						
27	231.91	218.79	120 20 50						
28	239.98	226.85	120 20 50						
29	248.05	234.92	120 20 50						
30	256.12	243.00	120 20 50						

Passo 1" 1/4 x 3/4"

per catene a rulli secondo
DIN 8188 - ISO/R 606 - ANSI B 29.1

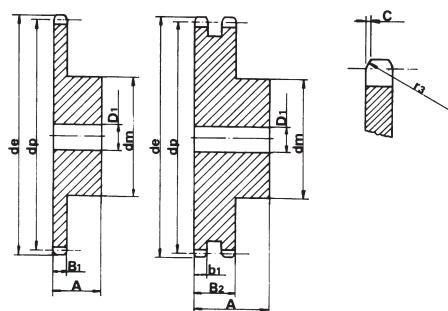

PIGNONE

RAGGIO DENTE r_3	33.5	mm
LARGHEZZA RAGGIO C	4	mm
LARGHEZZA DENTE B_1	18.0	mm
LARGHEZZA DENTE b_1	17.7	mm
LARGHEZZA DENTE B_2	53.5	mm
LARGHEZZA DENTE B_3	89.2	mm

CATENA

PASSO	31.75	mm
LARGHEZZA INTERNA	19.05	mm
RULLO \emptyset	19.05	mm

MATERIALE: C 45 UNI 7845

PIGNONI ASA 100

Z	SEMPLICI			DOPPI		
	d_e	d_p	d_m D ₁ A	d_m D ₁ A	d_m D ₁ A	
8	98.1	82.96	53 20 40			
9	108.0	92.84	63 20 40			
10	117.9	102.74	70 20 40			
11	127.8	112.68	77 20 45			
12	137.8	122.68	88 20 45	90 20 80		
13	147.8	132.65	98 20 45	100 20 80		
14	157.8	142.68	108 20 45	110 20 80		
15	167.9	152.72	118 20 45	120 20 80		
16	177.9	162.75	120 25 50	120 25 80		
17	187.9	172.78	120 25 50	120 25 80		
18	198.0	182.85	120 25 50			
19	208.1	192.91	120 25 50			
20	218.1	202.98	120 25 50			
21	228.2	213.04	140 25 55			
22	238.3	223.11	140 25 55			
23	248.3	233.17	140 25 55			
24	258.4	243.23	140 25 55			
25	268.5	253.33	140 25 55			



Passo 1" 1/2 x 1"

per catene a rulli secondo
DIN 8188 - ISO/R 606 - ANSI B 29.1

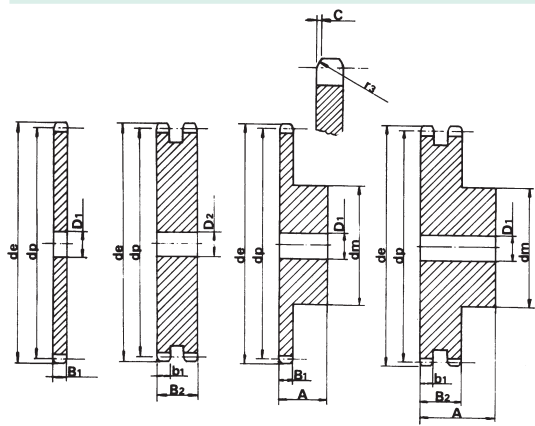

PIGNONI ASA 120

Z	SEMPLICI			DOPPI				
	d_e	d_p	d_m	D_1	A	d_m	D_1	A
8	119.04	99.55	58	20	45			
9	130.88	111.4	70	20	45			
10	142.77	123.29	80	20	45			
11	154.71	135.21	90	25	50			
12	166.69	147.22	102	25	50	102	25	100
13	178.68	159.18	114	25	50	114	25	100
14	190.7	171.22	128	25	50	128	25	100
15	202.73	183.26	140	25	50	140	25	100

PIGNONE

RAGGIO DENTE r_3	40.5	mm
LARGHEZZA RAGGIO C	4.8	mm
LARGHEZZA DENTE B_1	24.1	mm
LARGHEZZA DENTE b_1	23.6	mm
LARGHEZZA DENTE B_2	69	mm

CATENA

PASSO	38.1	mm
LARGHEZZA INTERNA	25.4	mm
RULLO \emptyset	22.22	mm

MATERIALE: C 45 UNI 7845 PIGNONI

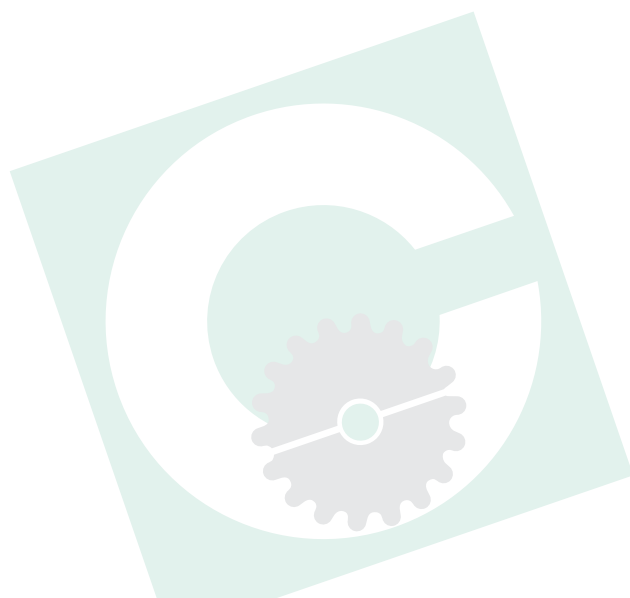

Tutte le dentature eliminate sono disponibili fino ad esaurimento.

A richiesta della Spett. Clientela possiamo eseguire dentature e passi nei profili ASA non indicati nel presente Catalogo in base a consuntivo.