









Pos.	Descrizione	Description	Benennung	Description	Descripción
1	Disco portasatelliti	Planet disc carrier	Planetenträgerscheibe	Porte satellite	Disco portasatelites
2	Albero disco	Shaft	Welle	Arbre de liaison	Eje disco
3	Coperchio collegamento	Connecting flange	Verbindungsflansch	Couvercle de liaison	Brida de union
4	Pignone	Pinion gear	Ritzel	Pignon	Piñon
5	Corona	Gear	Zahnrad	Couronne	Corona
6	Distanziale	Spacer ring	Distanzring	Entretoise	Distanciadore
7	Albero uscita	Output shaft	Abtriebswelle	Arbre de sortie	Eje de salida
8	Cassa riduzione "R"	Gear case	Gehäuse Vorstufe "R"	Carter R	Caja reccion R
9	Flangia uscita	Mounting flange	Befestigungsflansch	Bride F	Brida de salida
11	Spina	Dowel pin	Passtift	Goupille cylindrique	Pasador
20	Spina	Dowel pin	Passtift	Goupille cylindrique	Pasador
27	Guarnizione	Gasket	Dichtung	Joint plat	Junta
2014	Guarnizione	Gasket	Dichtung	Joint plat	Junta





									
	10	13	15	22	26	19	28	30	OR 7012
	[mm]	serie				[mm]			
VR 3	M6x18	6210	3208	6305	6306	M12x25	M6x22	M10x20	4462
VR 5.5	M6x18	6210	3208	6305	6306	M12x25	M6x22	M10x20	4462
VR 10	M6x14	6211	6309	6308	6310	M8x30	M8x30	M14x50	—

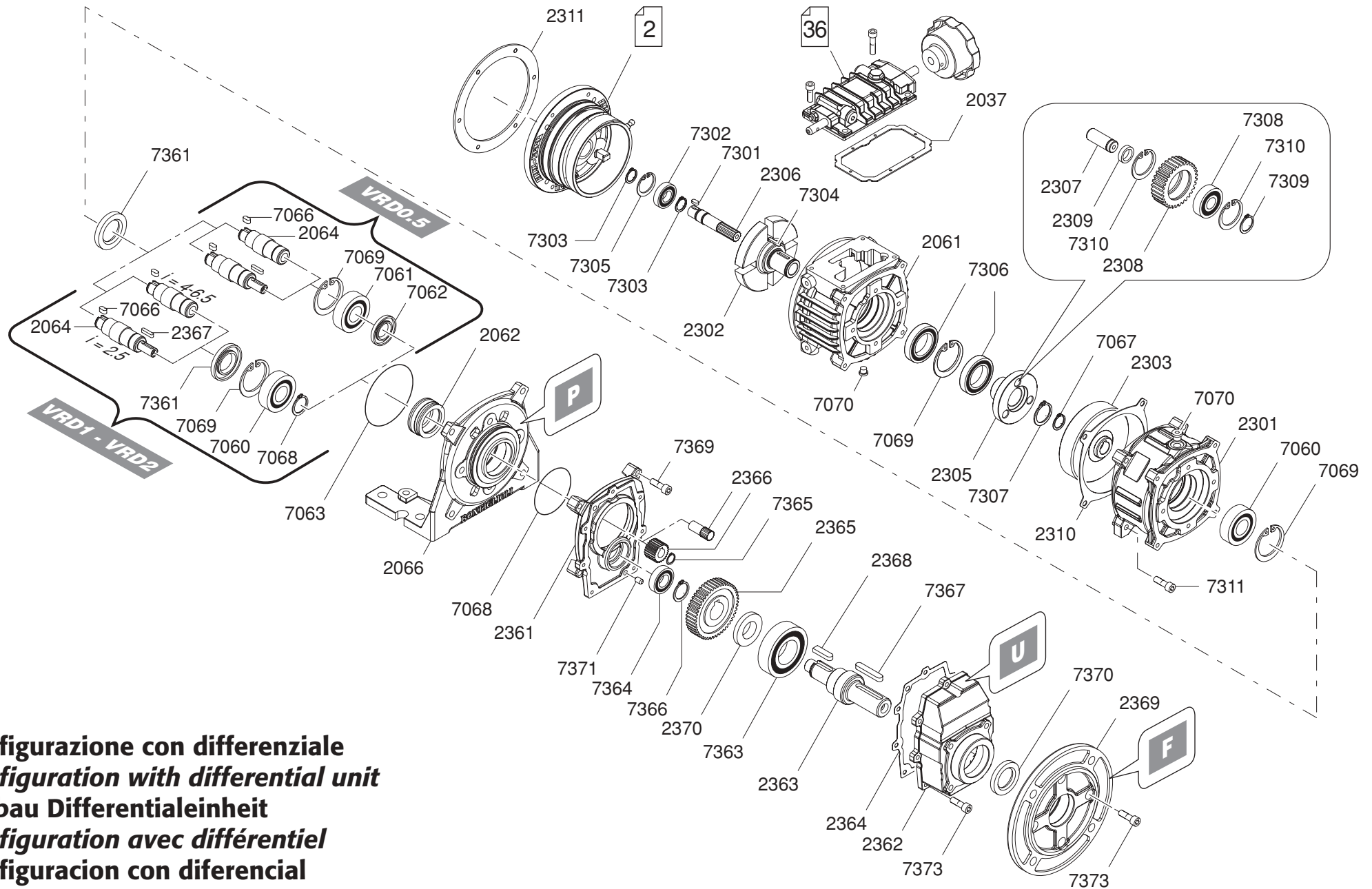



											
	12	25	14	18	21	23	16	29	55	17	24
	[mm]		De [mm]				[mm]			Di [mm]	
VR 3	6x5.3x26	8x7x25	50	40	18	28	40x72x7	45x65x8	10x8x70	90	72
VR 5.5	6x5.3x26	8x7x25	50	40	18	28	40x72x7	45x65x8	10x8x70	90	72
VR 10	8x7x40	14x9x40	55	45	28	40	45x80x10	60x90x10	14x9x90	100	110



Configurazione con differenziale
Configuration with differential unit
Aufbau Differentialeinheit
Configuration avec différentiel
Configuración con diferencial

Pos.	Descrizione	Description	Benennung	Description	Descripción
2037	Guarnizione	Gasket	Dichtung	Joint plat	Junta
2061	Cassa variatore	Variator housing	Variatorgehäuse	Carter U	Caja variador
2062	Supporto per cuscinetto	Bearing sleeve	Lagerbuchse	Support de roulement	Soporte para rodamiento
2064	Albero	Shaft	Welle	Arbre de liaison	Eje
2301	Cassa differenziale	Differential housing	Differentialgehäuse	Carter de différentiel	Caja Diferencial
2302	Disco portasatelliti	Planet disc carrier	Planetenträgerscheibe	Porte satellite	Disco portasatelites
2303	Corona differenziale	Differential ring gear	Ringrad Differential	Couronne différentiel	Corona diferencial
2305	Albero porta ingranaggio	Planet gear carrier	Planetenradträger	Porte planétaire	Eje portaengranajes
2306	Albero con pignone	Pinionshaft	Ritzelwelle	Pignon arbré	Eje con piñon
2307	Perno porta satellite	Roller	Zapfen für Zahnrad	Axe de planétaire	Perno porta satellite
2308	Ingranaggio satellite	Planet gear	Planetenrad	Engrenage planétaire	Engranaje satellite
2309	Distanziale	Spacer ring	Distanzring	Entretoise	Distanciador
2310	Guarnizione cassa differenziale	Gasket	Gehäusedichtung	Joint plat	Junta caja diferencial
2311	Guarnizione	Gasket	Dichtung	Joint plat	Junta
2361	Coperchio collegamento	Connecting flange	Verbindungsflansch	Couvercle de liaison	Brida de union
2362	Cassa riduzione addizionale	Gear case	Getriebegehäuse	Carter R	Caja reduccion adicional
2363	Albero uscita	Output shaft	Abtriebswelle	Arbre de sortie	Eje de salida
2364	Guarnizione	Gasket	Dichtung	Joint plat	Junta
2365	Corona	Gear	Zahnrad	Couronne	Corona
2366	Pignone	Pinion gear	Ritzel	Pignon	Piñon
2369	Flangia uscita	Output flange	Abtriebsflansch	Bride F	Brida de salida
2370	Distanziale	Spacer ring	Distanzring	Entretoise	Distanciador
7311	Vite di collegamento	Connecting bolt	Verbindungsschraube	Vis	Tornillo de fijacion
7369	Vite di collegamento	Connecting bolt	Verbindungsschraube	Vis	Tornillo de fijacion
7373	Vite di collegamento	Connecting bolt	Verbindungsschraube	Vis	Tornillo de fijacion



												
	7060	7061	7302	7306	7308	7363	7364	OR 7063	7070	7304	7066	7371
VRD 0.5	6204	6204	16002	61906	6000	6005	6201	3256	1/8" GAS	4x4x20	5x5x10	6x10
VRD 1	6206	—	16004	61908	6000	6005	6202	3300	1/4" GAS	5x5x25	8x7x14	6x10
VRD 2	6207	—	16005	61910	6202	6206	6204	3375	1/4" GAS	5x5x25	8x7x18	6x10

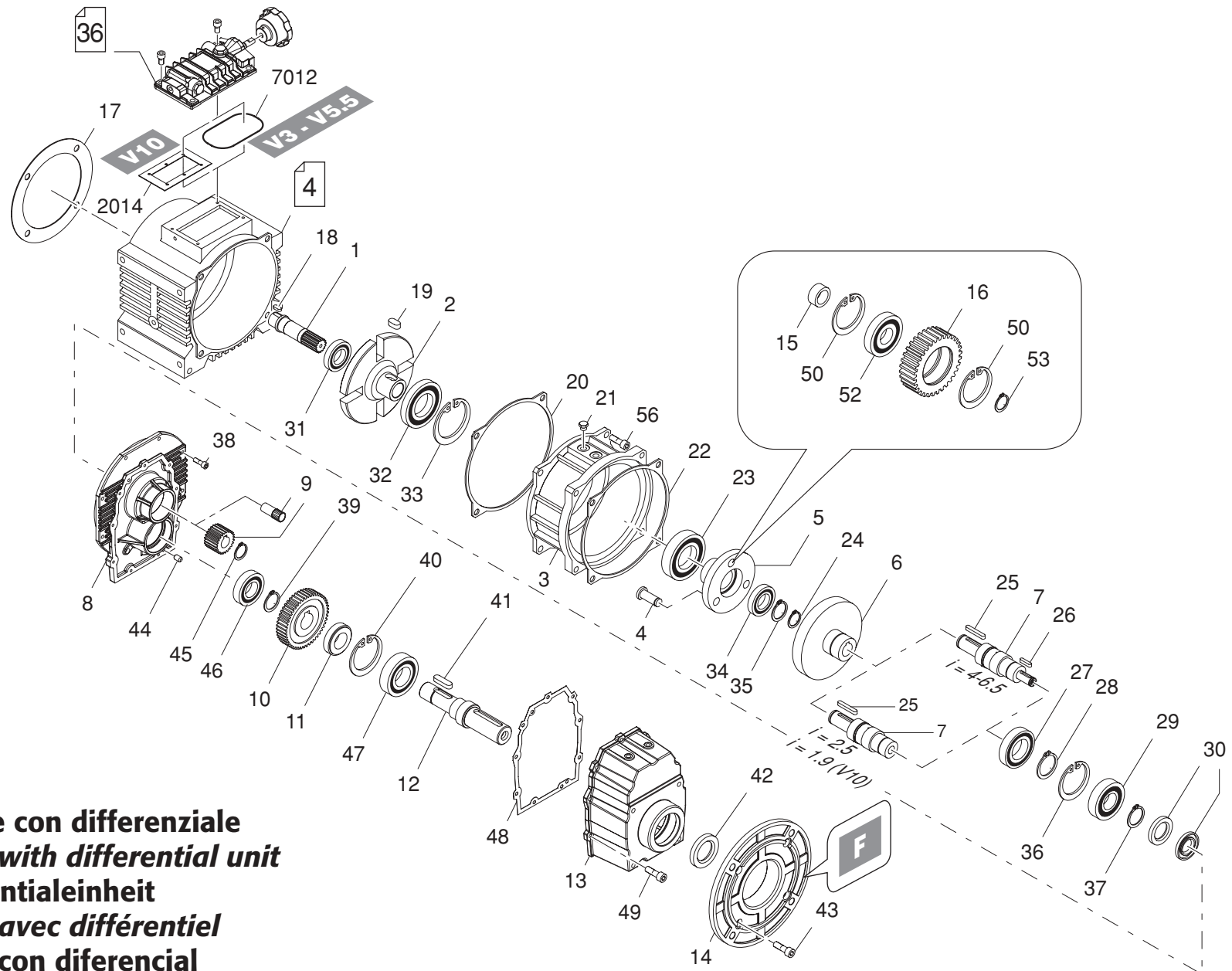

																	
	2367	2368	7066	7301	7367	7067	7068	7303	7307	7309	7366	7069	7305	7310	7062	7361	7370
VRD 0.5	4x4x16	6x6x15	5x5x10	5x4.5x10	6x6x35	16	20	15	24	10	17	47	32	26	25x35x7	25x47x7	30x42x7
VRD 1	5x5x17.8	6x6x16	8x7x14	6x5.5x12	8x7x45	24	30	20	29	10	19	62	42	26	—	35x62x7	30x42x7
VRD 2	6x6x20	8x7x19	8x7x18	8x6.5x13	8x7x50	28	35	25	35	15	24	72	47	35	—	40x72x7	35x52x7



Configurazione con differenziale
Configuration with differential unit
Aufbau Differentialeinheit
Configuration avec différentiel
Configuración con diferencial





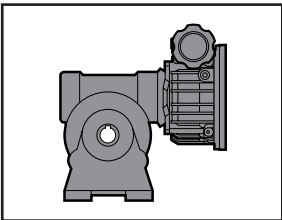
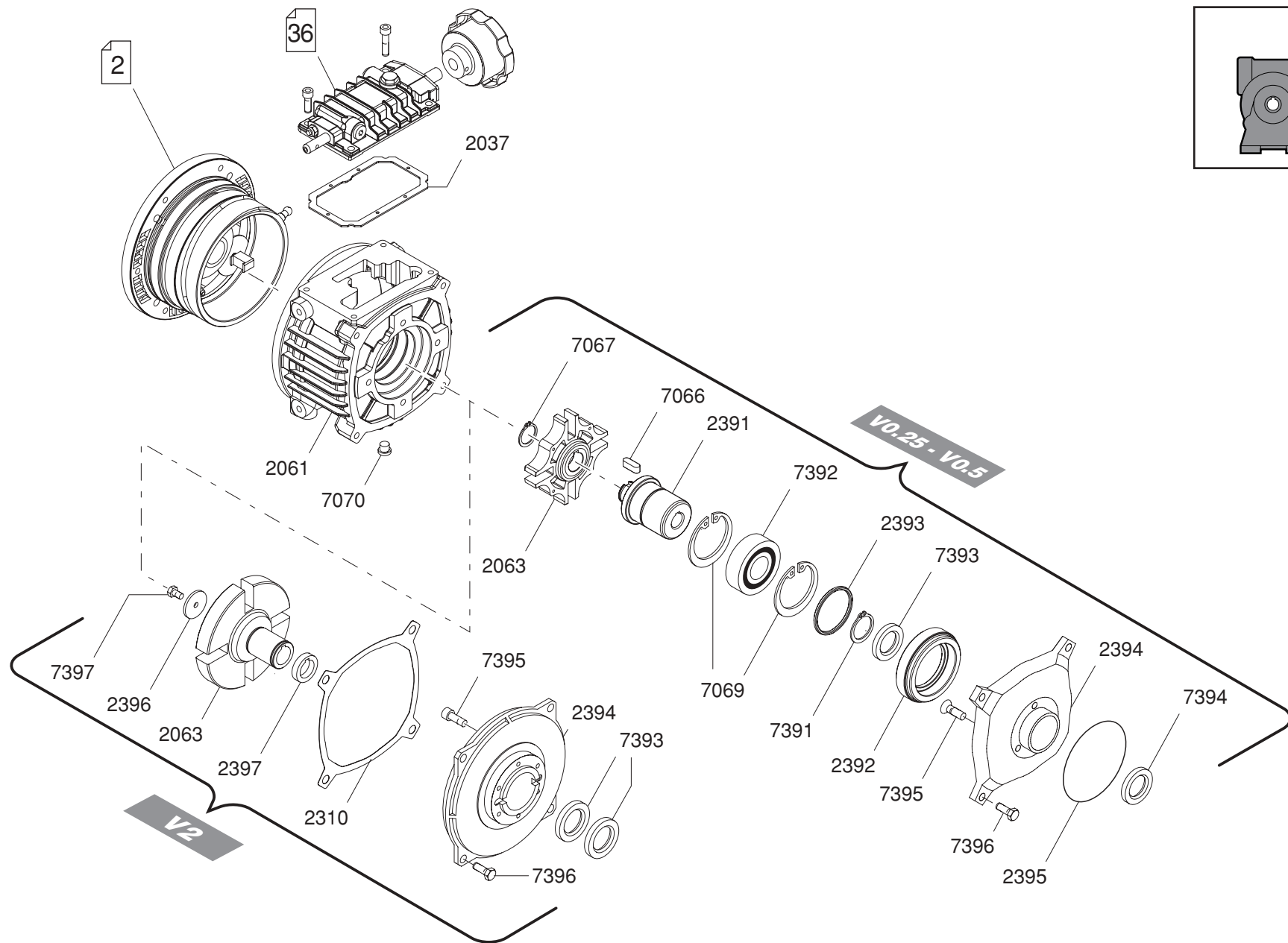

Pos.	Descrizione	Description	Benennung	Description	Descripción
1	Albero	Shaft	Welle	Pignon arbré	Eje
2	Disco portasatelliti	Planet disc carrier	Planetenträgerscheibe	Porte satellite	Disco portasatelites
3	Cassa differenziale	Differential housing	Differentialgehäuse	Carter de différentiel	Caja diferencial
4	Perno satelliti differenziale	Planet gear roller	Zapfen für Planetenrad	Axe de planétaire	Perno satelites diferencial
5	Disco motore	Tapered sun disc	Antriebscheibe	Porte planétaire	Disco motor
6	Corona differenziale	Differential ring gear	Ringrad Differential	Couronne différentiel	Corona diferencial
7	Albero	Shaft	Welle	Arbre de liaison	Eje
8	Coperchio di collegamento	Connecting flange	Verbindungsflansch	Couvercle de liaison	Brida de union
9	Pignone	Pinion gear	Ritzelwelle	Pignon	Piñon
10	Corona	Gear	Zahnrad	Couronne différentiel	Corona
11	Anello distanziale	Spacer ring	Distanzring	Entretoise	Anillo distanciadador
12	Albero uscita	Output shaft	Abtriebswelle	Arbre de sortie	Eje de salida
13	Scatola riduzione aggiuntiva	Gear case	Getriebegehäuse	Carter R	Caja de reduccion postiza
14	Flangia di fissaggio	Mounting flange	Befestigungsflansch	Bride F	Brida de fijacion
15	Anello distanziale	Spacer ring	Distanzring	Entretoise	Anillo distanciadador
16	Ingranaggio differenziale	Planet gear	Planetenrad	Engrenage planétaire	Engranaje diferencial
17	Guarnizione	Gasket	Dichtung	Joint plat	Junta
18	Linguetta	Key	Passfeder	Clavette	Chaveta
19	Linguetta	Key	Passfeder	Clavette	Chaveta
20	Guarnizione	Gasket	Dichtung	Joint plat	Junta
21	Tappo	Plug	Verschluß	Bouchon	Tapon
22	Guarnizione	Gasket	Dichtung	Joint plat	Junta
44	Spina	Dowel pin	Passtift	Goupille cylindrique	Pasador
48	Guarnizione	Gasket	Dichtung	Joint plat	Junta
2014	Guarnizione	Gasket	Dichtung	Joint plat	Junta
7012	O-ring	O-ring	O-Ring	Joint torique	Junta torica

																	
	23	27	29	31	32	34	46	47	52	30	42	38	43	49	55	56	
VRD 3	6011	6210	3208	6006	16011	6206	6305	6306	6303	40x72x7	45x65x8	M12x25	M10x20	M6x22	10x8x70	M12x25	
VRD 5.5	6011	6210	3208	6006	16011	6206	6305	6306	6303	40x72x7	45x65x8	M12x25	M10x20	M6x22	10x8x70	M12x25	
VRD 10	6011	6211	6309	6206	6011	6206	6308	6310	6303	45x80x10	60x90x10	M8x30	M14x50	M8x30	14x9x90	M8x30	

																	
	18	19	25	26	41	24	28	35	37	39	45	53	33	36	40	50	
VRD 3	8x6.5x18	6x6x30	8x7x50	6x5.3x26	8x7x25	28	50	30	40	28	18	17	90	90	72	47	
VRD 5.5	8x6.5x18	6x6x30	8x7x50	6x5.3x26	8x7x25	28	50	30	40	28	18	17	90	90	72	47	
VRD 10	10x7.5x20	6x6x30	10x8x65	8x7x40	14x9x40	35	55	30	45	40	28	17	90	100	110	47	



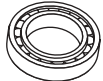

Pos.	Descrizione	Description	Benennung	Description	Descripción
2037	Guarnizione	Gasket	Dichtung	Joint plat	Junta
2061	Cassa	Housing	Gehäuse	Carter	Caja
2063	Disco portasatelliti	Planet disc carrier	Planetenträgerscheibe	Porte satellite	Disco portasatelites
2310	Guarnizione cassa	Gasket	Gehäusedichtung	Joint plat	Junta
2391	Albero uscita	Output shaft	Abtriebswelle	Arbre de sortie	Eje de salida
2392	Supporto uscita	Support sleeve	Halterung	Support	Casquillo soporte
2393	Distanziale	Spacer ring	Distanzring	Entretoise	Distanciador
2394	Flangia di collegamento	Connecting flange	Verbindungsflansch	Bride de liaison	Brida de fijacion
2395	Guarnizione OR	O-ring	O-Ring	Joint torique	Junta torica
2396	Rondella	Washer	Scheibe	Rondelle	Arandela
2397	Distanziale	Spacer ring	Distanzring	Entretoise	Distanciador
7395	Vite di collegamento	Connecting bolt	Verbindungsschraube	Vis	Tornillo de fijacion
7396	Vite di collegamento	Connecting bolt	Verbindungsschraube	Vis	Tornillo de fijacion

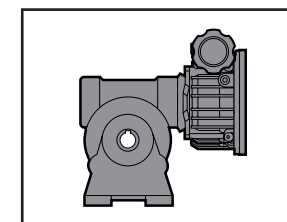
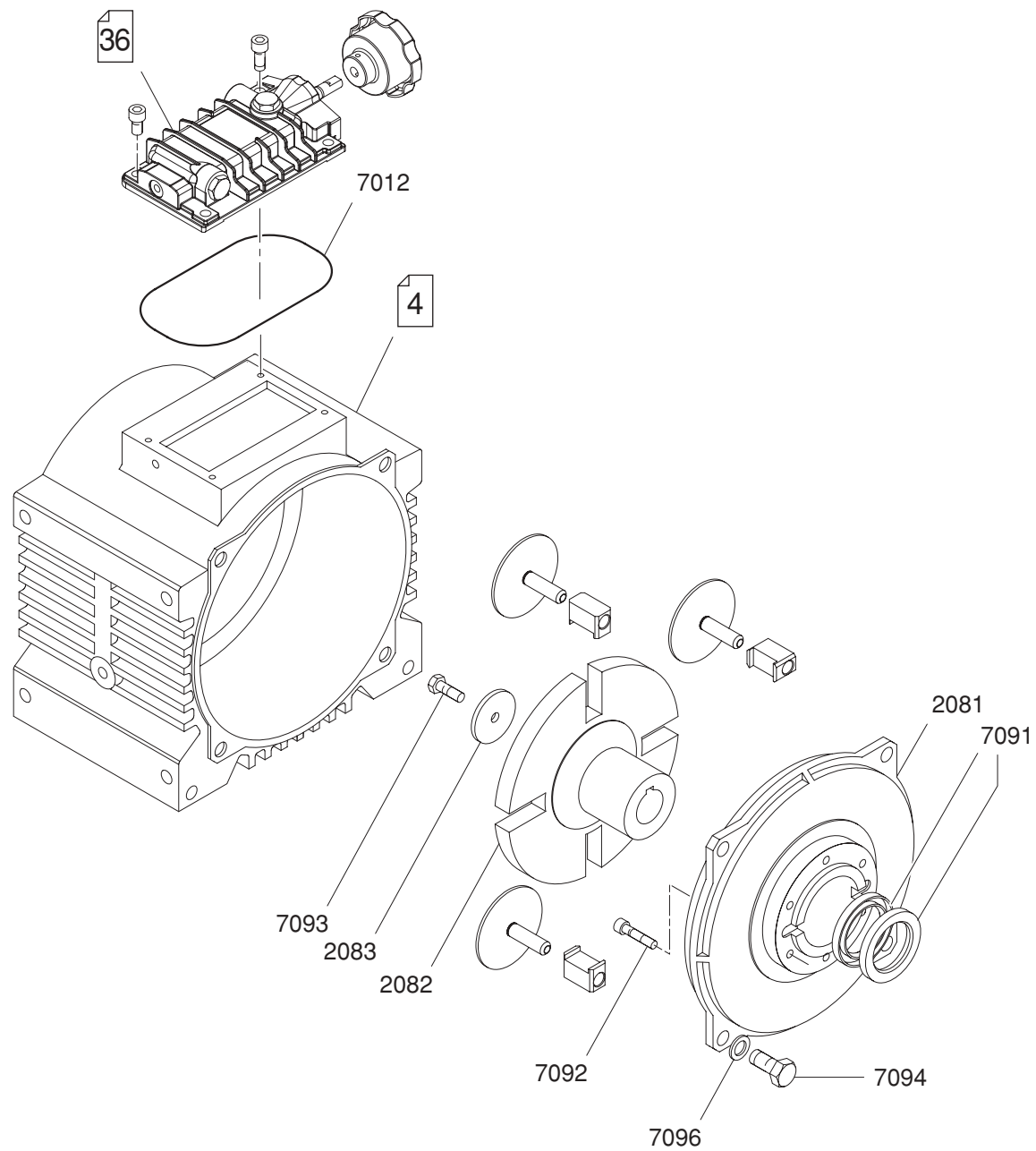
									
	7066	7069	7070	7391	7067	7392	7393	7394	7397
	[mm]	Di [mm]		De [mm]		serie	[mm]		[mm]
V 0.25 C	5x5x10	47	1/8" GAS	30	16	61906	30x47x7	15x30x4.5	—
V 0.5 C	5x5x10	47	1/8" GAS	30	16	61906	30x47x7	20x30x7	—
V 2 C	—	—	1/4" GAS	—	—	—	35x67x7	—	M8x25







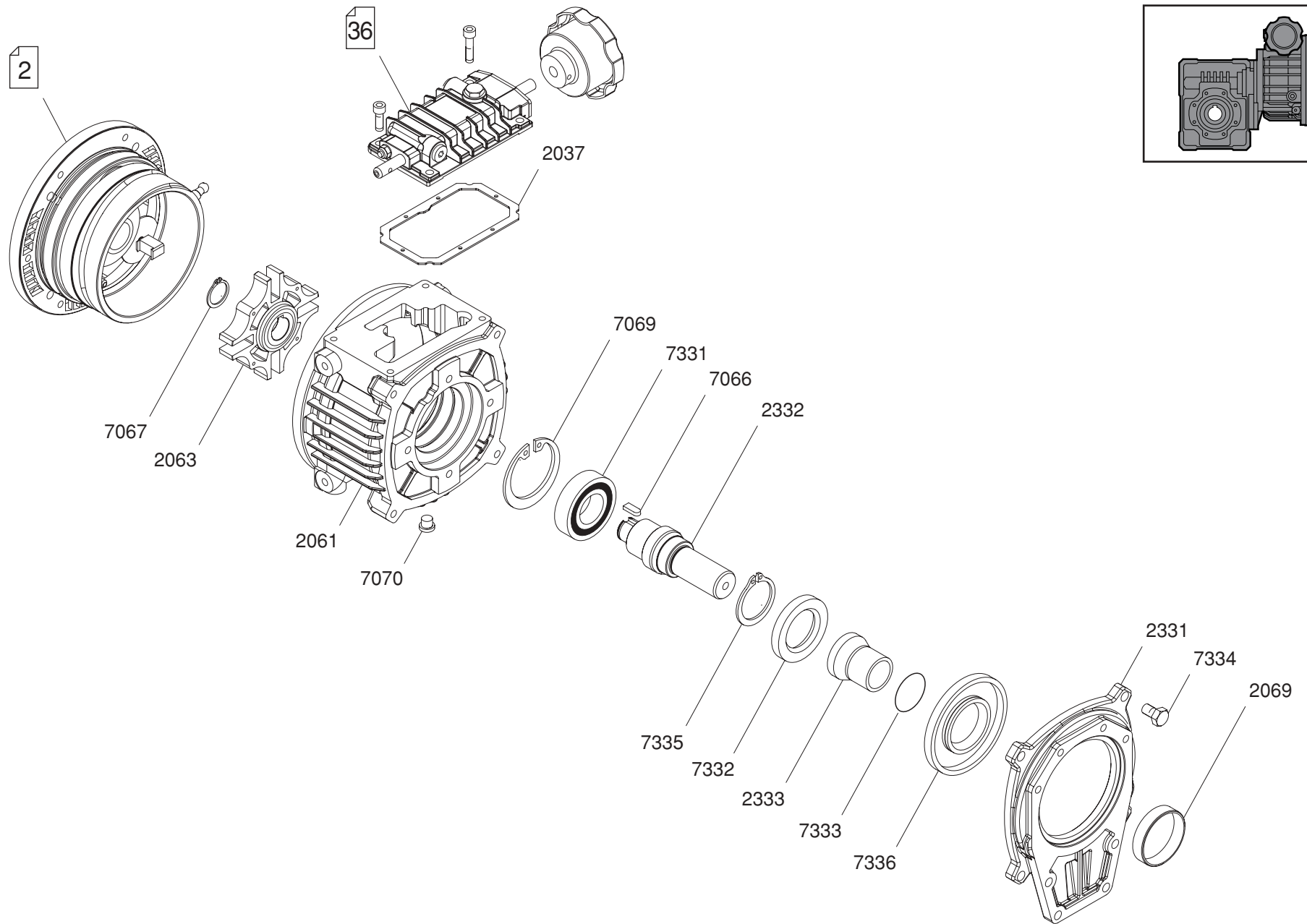

Pos.	Descrizione	Description	Benennung	Description	Descripción
2081	Coperchio di collegamento	Connecting flange	Verbindungsflansch	Bride de liaison	Brida de union
2082	Disco uscita portasatelliti	Planet disc carrier	Planetenträgerscheibe	Porte satellite	Disco portasatelites a la salida
2083	Rondella	Washer	Scheibe	Rondelle	Arandela
7092	Vite di collegamento	Connecting bolt	Verbindungsschraube	Vis	Tornillo de fijacion
7094	Vite di collegamento	Connecting bolt	Verbindungsschraube	Vis	Tornillo de fijacion
7096	Rosetta	Washer	Scheibe	Rondelle	Arandela

	 OR	 7091			
	7012	VF 110	VF 130	VF 150	7093
		[mm]			[mm]
V 3 C	4462	30x62x7	35x62x7	40x72x7	M8x22
V 5.5 C	4462	30x62x7	35x62x7	40x72x7	M8x22



Pos.	Descrizione	Description	Benennung	Description	Descripción
2037	Guarnizione	Gasket	Dichtung	Joint plat	Junta
2061	Cassa	Housing	Gehäuse	Carter	Caja
2063	Disco portasatelliti	Planet disc carrier	Planetenträgerscheibe	Porte satellite	Disco portasatelites
2069	Distanziale	Spacer ring	Distanzring	Entretoise	Distanciador
2331	Coperchio di collegamento	Connecting flange	Verbindungsflansch	Bride de liaison	Tapa de union
2332	Albero uscita	Output shaft	Abtriebswelle	Arbre de sortie	Eje de salida
2333	Boccola	Bushing	Buchse	Bague	Casquillo
7334	Vite di collegamento	Connecting bolt	Verbindungsschraube	Vis	Tornillo de fijacion

	 7066 [mm]	 7067	7335	 7069 Di [mm]	 7070	 7331 serie	 7332	7336 [mm]	 OR 7333
V 0.5 C	5x5x10	16	—	47	1/8" GAS	6005	30x47x7	—	4134
V 1 C	8x7x14	24	—	62	1/4" GAS	6007	40x62x7	—	4131
V 2 C	8x7x18	28	50	72	1/4" GAS	61910	50x72x8	50x80x8	4150

V 0.25 C

V 0.5 C

V 1 C



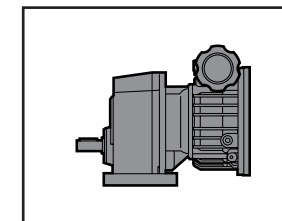
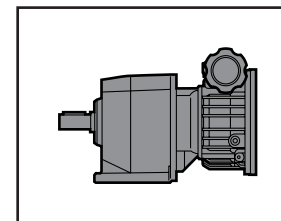
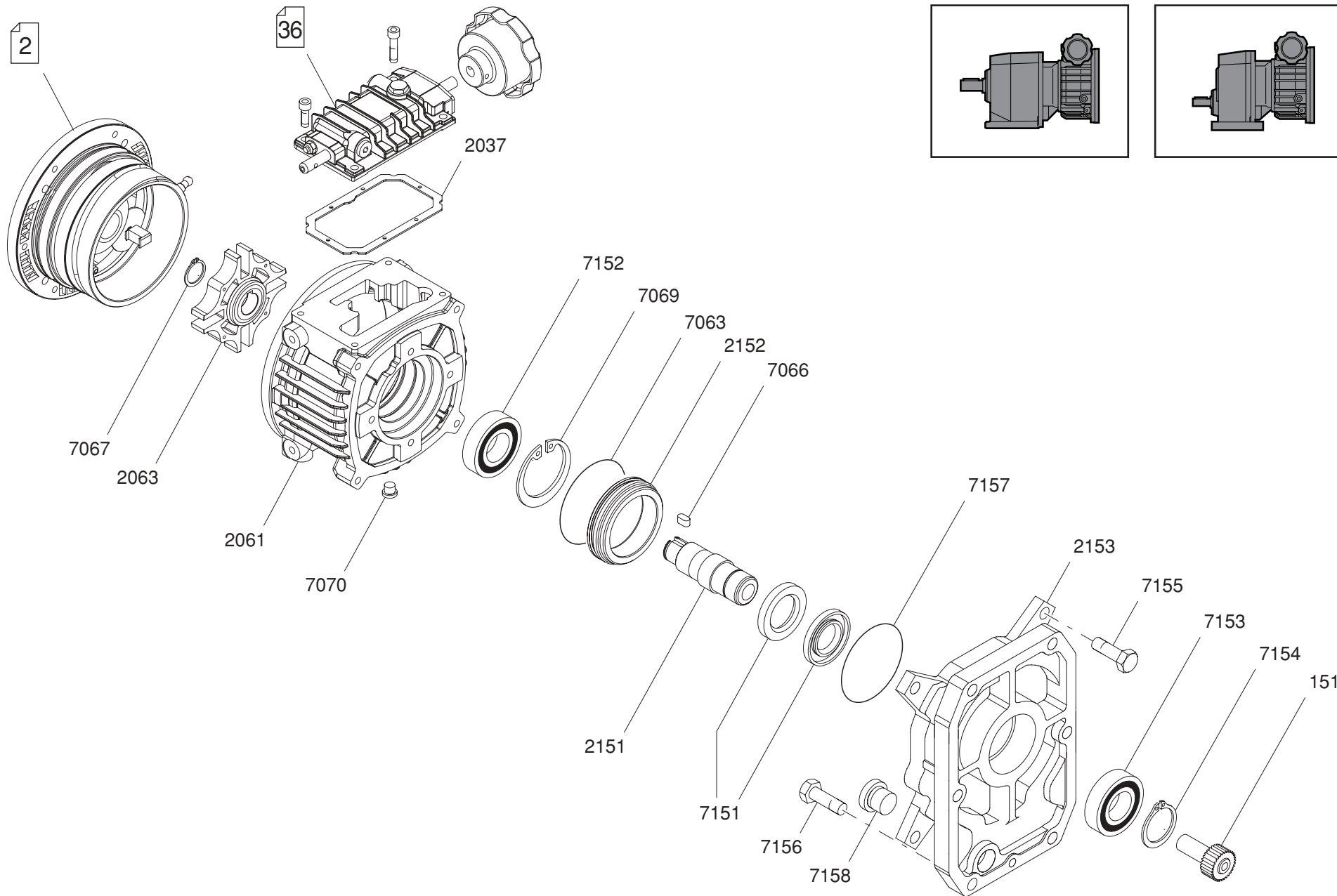

V 2 C

C+V

S+V

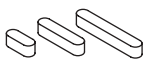

Pos.	Descrizione	Description	Benennung	Description	Descripción
151	Pignone elicoidale	Helical pinion gear	Ritzel	Pignon hélicoïdal	Piñon helicoidal
2037	Guarnizione	Gasket	Dichtung	Joint plat	Junta
2061	Cassa	Housing	Gehäuse	Carter	Caja
2063	Disco portasatelliti	Planet disc carrier	Planetenträgerscheibe	Porte satellite	Disco porta satelites
2151	Albero di collegamento	Connecting shaft	Kupplungswelle	Arbre de liaison	Eje de union
2152	Supporto uscita	Support sleeve	Halterung	Support	Soporte de salida
2153	Coperchio di collegamento	Connecting flange	Verbindungsflansch	Bride de liaison	Tapa de union
7155	Vite di collegamento	Connecting bolt	Verbindungsschraube	Vis	Tornillo de fijacion
7156	Vite di collegamento	Connecting bolt	Verbindungsschraube	Vis	Tornillo de fijacion

	 OR											
	7063	7157	7066	7067	7154	7069	7070	7158	7151	7152	7153	
			[mm]	De [mm]		Di [mm]			[mm]	serie		
V 0.25 C	3225	2175	5x5x10	16	17	47	1/8" GAS	1/4" GAS	20x35x7	6204	6203	
V 0.5 C	3256	2175	5x5x10	16	17	47	1/8" GAS	1/4" GAS	20x35x7	6204	6203	
V 1 C	3300	—	8x7x14	24	30	62	1/4" GAS	1/4" GAS	35x52x7	6206	6206	
V 2 C	3375	—	8x7x18	28	35	72	1/4" GAS	1/4" GAS	40x62x7	6207	6207	

V 3 C

V 5.5 C





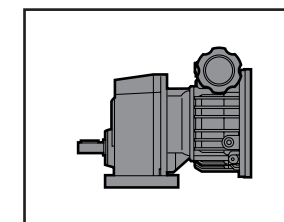
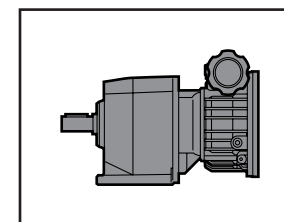
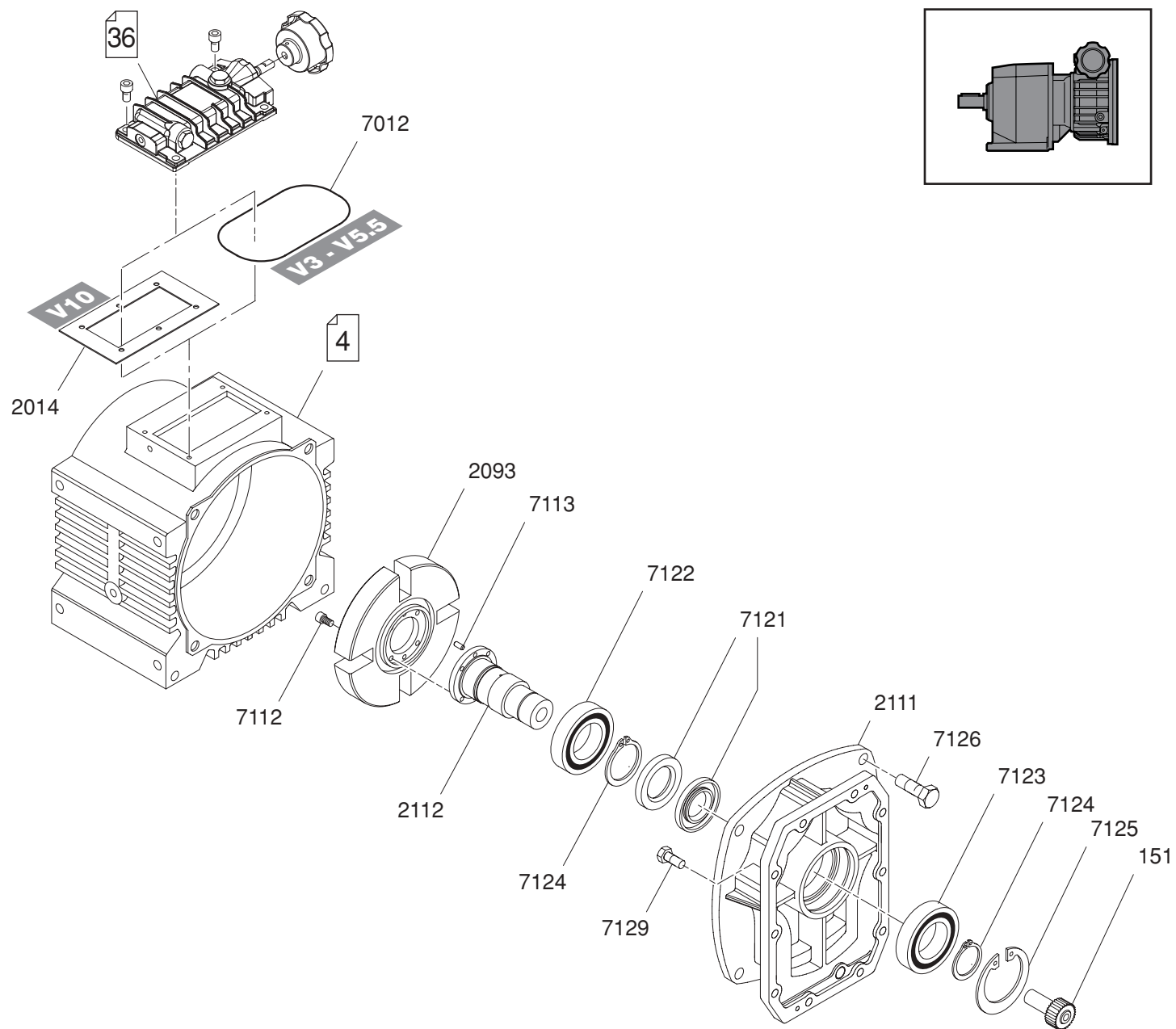

V 10 C

C+V

S+V

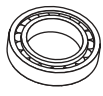

Pos.	Descrizione	Description	Benennung	Description	Descripción
151	Pignone elicoidale	Helical pinion gear	Ritzel	Pignon hélicoïdal	Piñon helicoidal
2014	Guarnizione	Gasket	Dichtung	Joint plat	Junta
2093	Disco portasatelliti	Planet disc carrier	Planetenträgerscheibe	Porte satellite	Disco portasatelites
2111	Coperchio di collegamento	Connecting flange	Verbindungsflansch	Bride de liaison	Tapa de union
2112	Albero di collegamento	Connecting shaft	Verbindungswelle	Arbre de liaison	Eje de union
7126	Vite di collegamento	Connecting bolt	Verbindungsschraube	Vis	Tornillo de fijacion
7129	Vite di collegamento	Connecting bolt	Verbindungsschraube	Vis	Tornillo de fijacion

	 OR 7012	 7112 [mm]	 7113 [mm]	 7121 [mm]	 7122 7123 serie	 7124 De [mm]	 7125 Di [mm]
V 3 C	4462	M6x12	6x16	50x72x8	6210 6308	40	90
V 5.5 C	4462	M6x12	6x16	50x72x8	6210 6308	40	90
V 10 C	—	M8x14	8x16	55x80x8	6211 6309	45	—

V 0.25

V 0.5

V 1

V 2

V 3

V 5.5



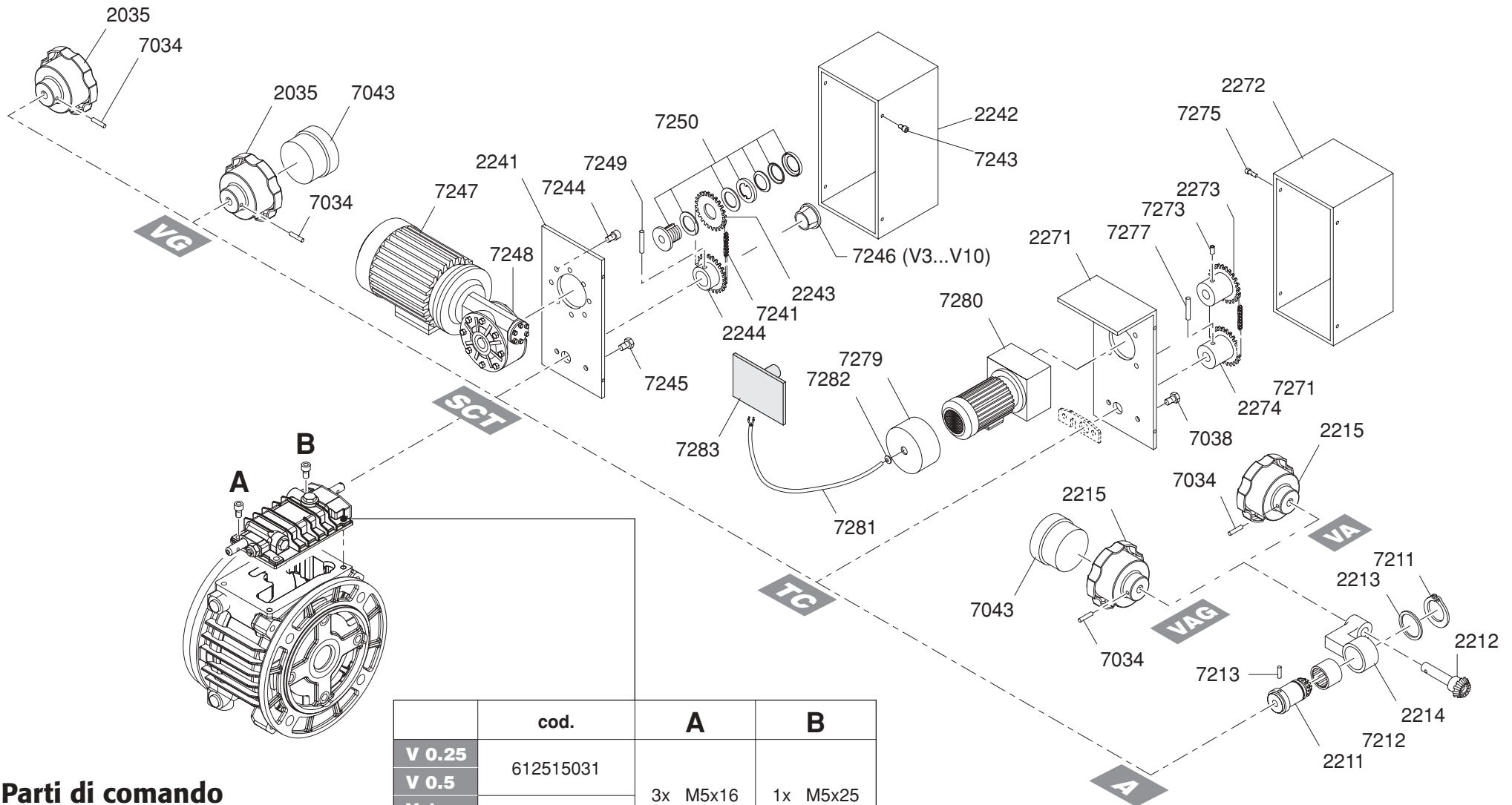





V 10



Parti di comando
Speed adjusting parts
Einzelteile Verstelleinrichtung
Accessoires de commande
Partes del mando

	cod.	A	B
V 0.25	612515031	3x M5x16	1x M5x25
V 0.5			
V 1	612515029		
V 2			
V 3	612515026	4x M6x18	
V 5.5			
V 10	612515019	6x M6x25	



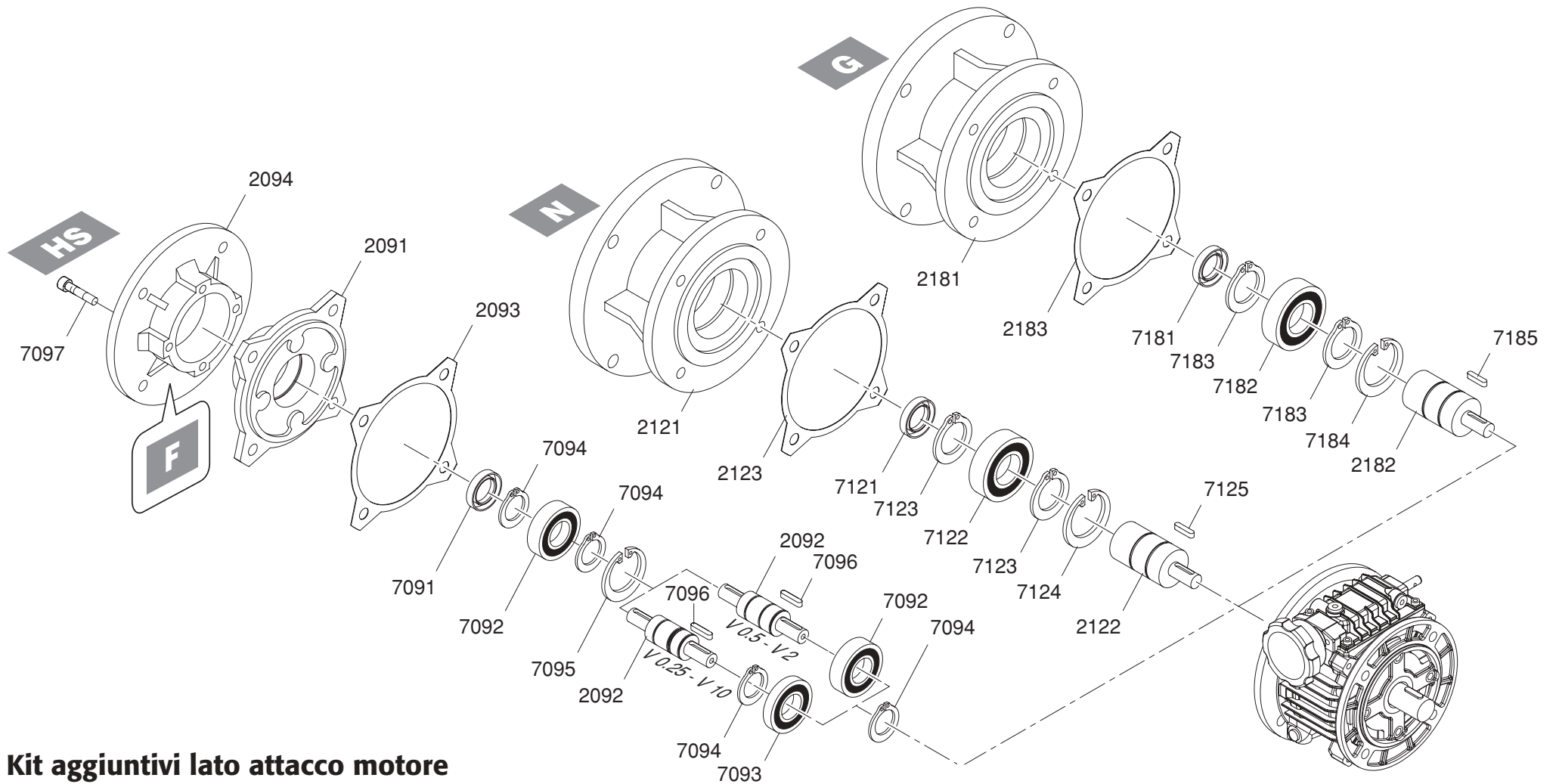

Pos.	Descrizione	Description	Benennung	Description	Descripción
2035	Volantino di comando	Handwheel	Handrad	Volant de commande	Volante de regulacion
2211	Pignone condotto	Driven pinion	Abtriebsritzel	Pignon conduit	Piñon conducido
2212	Pignone conduttore	Drive pinion	Antriebsritzel	Pignon menant	Piñon conductor
2213	Distanziale	Spacer	Distanzring	Entretoise	Distanciador
2214	Corpo	Support	Aufnahme	Support	Cuerpo
2215	Volantino di comando	Handwheel	Handrad	Volant de commande	Volante de regulacion
2241	Staffa di supporto	Bracket	Montageplatte	Platine	Cartela de soporte
2242	Coperchio	Safety cover	Schutzhaube	Couvercle	Tapa
2243	Pignone conduttore	Drive pinion	Antriebsritzel	Pignon conduit	Piñon conductor
2244	Pignone condotto	Driven pinion	Abtriebsritzel	Pignon menant	Piñon conducido
2271	Staffa di supporto	Bracket	Montageplatte	Platine	Cartela de soporte
2272	Coperchio di chiusura	Safety cover	Schutzhaube	Couvercle	Tapa de cierre
2273	Pignone conduttore	Drive pinion	Antriebsritzel	Pignon conduit	Piñon conductor
2274	Pignone condotto	Driven pinion	Abtriebsritzel	Pignon menant	Piñon conducido
7038	Vite di fissaggio	Screw	Schraube	Vis	Tornillo de fijacion
7043	Indicatore di giri	Turns indicator	Schleppanzeige	Indicateur gravitationel	Indicador de vueltas
7241	Catena	Chain	Kette	Chaîne	Cadena
7243	Vite di fissaggio	Screw	Schraube	Vis	Tornillo de fijacion
7244	Vite di fissaggio	Screw	Schraube	Vis	Tornillo de fijacion
7245	Vite di fissaggio	Screw	Schraube	Vis	Tornillo de fijacion
7246	Calettatore	Cone clamping	Spannbüchse	Moyeu de serrage	Aro conico de apriete
7247	Motore	Motor	Motor	Moteur	Motor
7248	Riduttore	Gear unit	Getriebe	Réducteur	Reductor
7250	Limitatore di coppia	Torque limiter	Rutschkupplung	Limiteur de couple	Limitador de par
7271	Catena	Chain	Kette	Chaîne	Cadena
7275	Vite di fissaggio	Screw	Schraube	Vis	Tornillo de fijacion
7279	Tappo di plastica	Plastic cover	Kunststoffhaube	Bouchon plastique	Tapon de plastico
7280	Motore	Motor	Motor	Moteur	Motor
7281	Guaina	Sheath	Ummantelung	Gaine	Proteccion
7282	Pressacavo	Cable gland	Kabelverschraubung	Presse étoupe	Prensaestopas
7283	Scheda elettronica	Electronic board	Elektronikkarte	Carte électronique	Tarjeta electronica

															
	7034	7213	7249	7277	7211	7212	7273		7034	7213	7249	7277	7211	7212	7273
V 0.25								V 3							
V 0.5								V 5.5							
V 1	4x30	4x30	4x30	4x26	Di= 26	20x30x17	M4x5	V 10	4x30	4x30	4x30	4x26	Di= 26	20x30x17	M4x5
V 2															

V 0.25**V 0.5****V 1****V 2****V 3****V 5.5****V 10**

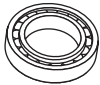
Kit aggiuntivi lato attacco motore
Add-on input parts
Zusätzliche Eingangsbaugruppen
Kits d'entrée
Kit a añadir en el lado fijacion motor

Pos.	Descrizione	Description	Benennung	Description	Descripción
2091	Coperchio entrata	Front cover	Frontdeckel	Couvercle d'entrée	Tapa de entrada
2092	Albero entrata	Input shaft	Eingangswelle	Arbre d'entrée	Eje de entrada
2093	Guarnizione entrata	Gasket	Dichtung	Joint plat	Junta de entrada
2094	Flangia	Flange	Flansch	Bride	Brida
2121	Flangia attacco motore	Motor mounting flange	Motorbefestigungsflansch	Bride moteur	Brida fijacion motor
2122	Albero entrata cavo	Hollow input shaft	Eingangshohlwelle	Arbre d'entrée creux	Eje de entrada hueco
2123	Guarnizione entrata	Gasket	Dichtung	Joint plat	Junta de entrada
2181	Flangia attacco motore	Motor mounting flange	Motorbefestigungsflansch	Bride moteur	Brida fijacion motor
2182	Albero entrata cavo	Hollow input shaft	Eingangshohlwelle	Arbre d'entrée creux	Eje de entrada hueco
2183	Guarnizione entrata	Gasket	Dichtung	Joint plat	Junta de entrada
7097	Vite di collegamento	Connecting bolt	Verbindungsschraube	Vis	Tornillo de fijacion

																
	7091	7121	7181	7092	7093	7122	7182	7094	7123	7183	7095	7124	7184	7096	7125	7185
	[mm]			serie				De [mm]			Di [mm]			[mm]		
V 0.25	20x30x7	30x40x7	20x40x7	16004	6004	6006	6005	20	30	25	42	55	47	4x4x20	4x4x20	4x4x20
V 0.5	30x42x7	30x42x7	35x52x7	—	16006	6006	6007	30	30	35	55	55	62	5x5x25	5x5x25	5x5x25
V 1	35x52x7	35x52x7	40x62x7	6007	16007	6007	6208	35	35	40	62	62	80	6x6x20	6x6x30	6x6x30
V 2	40x62x7	40x62x7	45x72x8	6208	—	6208	6209	40	40	45	80	80	85	8x7x40	6x6x30	8x7x40
V 3	45x72x8	45x72x8	55x80x8	6209	6209	6209	6211	45	45	55	85	85	100	8x7x50	8x7x50	8x7x50
V 5.5	45x72x8	45x72x8	55x80x8	6209	6209	6209	6211	45	45	55	85	85	100	8x7x50	8x7x50	8x7x50
V 10	45x80x10	55x80x8	60x90x10	6309	6309	6211	6212	45	55	60	100	100	110	10x8x70	10x8x70	10x8x70

R0					
	Descrizione	Description	Benennung	Description	Descripción

Questa pubblicazione annulla e sostituisce ogni precedente edizione o revisione. Ci riserviamo il diritto di apportare modifiche senza preavviso. E' vietata la riproduzione anche parziale senza autorizzazione.

This publication cancels and replaces any previous edition and revision. We reserve the right to implement modifications without notice. This catalogue cannot be reproduced, even partially, without prior consent.

Diese Veröffentlichung annulliert und ersetzt jeder hergehende Edition oder Revision. BONFIGLIOLI behält sich das Recht vor, Änderungen ohne vorherige Informationen durchzuführen.

Cette publication annule et remplace toutes les autres précédentes. Nous nous réservons le droit d'apporter toutes modifications à nos produits. La reproduction et la publication partielle ou totale de ce catalogue est interdite sans a autorisation.

Esta publicación anula y sustituye toda anterior edición o revisión. Nos reservamos el derecho de aportar modificaciones sin previo aviso. Se prohíbe la reproducción incluso parcial sin autorización.

Bonfiglioli Worldwide & BEST Partners

AUSTRALIA

BONFIGLIOLI TRANSMISSION (Aust) Pty Ltd.
48-50 Adderley St. (East) Auburn (Sydney) N.S.W. 2144
Tel. (+61) 2 8748 4400 - Fax (+61) 2 9748 8740
P.o. Box 6705 Silverwater NSW 1811
www.bonfiglioli.com.au - sales@bonfiglioli.com.au

AUSTRIA 

MOLL MOTOR GmbH
Industriestrasse 8 - 2000 Stockerau
Tel. (+43) 2266 63421+DW - Fax (+43) 6342 180
www.mollmotor.at - office@mollmotor.at

BELGIUM 

N.V. ESCO TRANSMISSION S.A.
Culliganlaan 3 - 1831 Machelem Diegem
Tel. 0032 2 7204880 - Fax 0032 2 7212827 - Tlx 21930 Escopo B
www.escotrans.be - info@escotrans.be

BRASIL 

ATI BRASIL
Rua Omílio Monteiro Soares, 260 - Vila Fanny - 81030-000
Tel. (+41) 334 2091 - Fax (+41) 332 8669
www.atibrasil.com.br - vendas@atibrasil.com.br

CANADA

BONFIGLIOLI CANADA INC.
2-7941 Jane Street - Concord, ONTARIO L4K 4L6
Tel. (+1) 905 7384466 - Fax (+1) 905 7389833
www.bonfigliolicanada.com - sales@bonfigliolicanada.com

CHINA

BONFIGLIOLI DRIVES (SHANGHAI) CO. LTD.
No. 8 Building, 98 Tian Ying Road - Qingpu District, Shanghai, PRC 201700
Tel. +86 21 69225500 - Fax +86 21 69225511
www.bonfiglioli.cn - linkn@bonfiglioli.com.cn

FRANCE

BONFIGLIOLI TRANSMISSIONS S.A.
14 Rue Eugène Pottier BP 19
Zone Industrielle de Moiront II - 95670 Marly la Ville
Tel. (+33) 1 34474510 - Fax (+33) 1 34688800
www.bonfiglioli.fr - btf@bonfiglioli.fr

GERMANY

BONFIGLIOLI DEUTSCHLAND GmbH
Hamburger Straße 18 - 41540 Dormagen
Tel. (+49) 2133 50260 - Fax (+49) 2133 502610
www.bonfiglioli.de - info@bonfiglioli.de

GRAT BRITAIN

BONFIGLIOLI UK Ltd
Unit 3 Colemeadow Road - North Moons Moat
Redditch, Worcestershire B98 9PB
Tel. (+44) 1527 65022 - Fax (+44) 1527 61995
www.bonfiglioli.co.uk - marwaha@bonfiglioli.com

BONFIGLIOLI (UK) LIMITED
5 Grosvenor Grange - Woolston - Warrington, Cheshire WA1 4SF
Tel. (+44) 1925 852667 - Fax (+44) 1925 852668
www.bonfiglioliuk.co.uk - sales@bonfiglioliuk.co.uk

GREECE

BONFIGLIOLI HELLAS S.A.
O.T. 48A T.O. 230 - C.P. 570 22 Industrial Area - Thessaloniki
Tel. (+30) 2310 796456 - Fax (+30) 2310 795903
www.bonfiglioli.gr - info@bonfiglioli.gr

HOLLAND 

ELSTO AANDRIJFTECHNIEK
Loostenweg, 7 - 2215 TL Voorhout
Tel. (+31) 252 219 123 - Fax (+31) 252 231 660
www.elsto.nl - info@elsto.nl

HUNGARY 

AGISYS AGITATORS & TRANSMISSIONS Ltd
2045 Törökbálint, Tó u.2. Hungary
Tel. +36 23 50 11 50 - Fax +36 23 50 11 59
www.agisys.hu - info@agisys.com

INDIA

BONFIGLIOLI TRANSMISSIONS PVT Ltd.
PLOT AC7-AC11 Sidco Industrial Estate
Thiruvudavakkam - Chennai 600 044
Tel. +91(0)44 24781035 / 24781036 / 24781037
Fax +91(0)44 24780091 / 24781904
www.bonfiglioli.co.in - bonfig@vsnl.com

ITALY

A.T.I. di Morganti E. C. sas 
Via Pistoiese 219 - 50047 Prato (PO)
Tel. 0574/6961 - Fax 0574/790996
www.atimorganti.it - ati.morganti@texnet.it

BONETTI LUIGI SRL 
Strada Padana Superiore verso VR n.7 - 36100 Vicenza (VI)
Tel. 0444/563120 - Fax 0444/961979
www.bonettimotoriduttori.com - bonetti.luigi@libero.it

CASA DEL CUSCINETTO SAS di Castignoli e C. 
Strada Val Nure 18/a - 29100 Piacenza (PC)
Tel. 0523/755518 - 0523/756315 - Fax 0523/457804
www.casadelcuscinetto.net - antonio@casadelcuscinetto.net

CENTO TRASMISSIONI SRL 
Via Friuli 23 - 40060 Osteria Grande (BO)
Tel. 051/6958222 - Fax 051/6958253
www.centotrasmissioni.com - cento@centotrasmissioni.com

CONTASTA COMPONENTI SRL 
di Franca Di Clemente e Figli
Via Po 65/67 - Zona Comm. 66020 S.Giovanni Teatino (CH)
Tel. 085/4462696 - Fax 085/4461754
www.grupprofitt.it - grupprofitt@grupprofitt.it

D.L. di Danielli B e Lollì G. SRL 
Via Fucini 2 - 40132 Bologna
Tel. 051/6177611 - Fax 051/6177630
www.daniellielolli.it - info@daniellielolli.it

EGA TECNIC SRL 
Via Maccani 17/12 - 38100 Trento
Tel. 0461 822176 - Fax 0461 821643
www.egatecnic.it - info@egatecnic.it

FIMU S.R.L. 
Via Artigianato - 25128 Savigliano (CN)
Tel. 0172/713542 - Fax 0172/715489
www.fimusrl.com - fimu@fimusrl.com

FITMA S.R.L. 
Viale del Commercio 10 - 37042 Caldiero (VR)
Tel. 045/6132511 - Fax 045/6150270
www.fitma.it - fitma@fitma.it

F.M.I. FRANCESCHI S.R.L. 
Strada Baganzola 28/a - 43100 Parma
Tel. 0521/992200 - Fax 0521/987303
www.fmiparma.it - fmi@fmiparma.it

INDUSTRIAL FURNITURE MORO SNC 
Via dei Da Prata 34 - 31100 Treviso
Tel. 0422 428835 - Fax 0422/428830
www.morotrevise.com - info@morotrevise.com

MICAR Snc di Sandro Arminio e C. 
Via Rosso di S. Secondo, 15 - 20134 Milano
Tel. 02/7491091 - Fax 02/70126372
www.micar.it - info@micar.it

MINETTI SPA FILIALE DI BERGAMO 
Via Canovine, 14 - 24100 Bergamo
Tel. 035/327111 - Fax 035/316767
www.minettigroup.com - minettiberghamo@minettigroup.com

MINETTI SPA FILIALE DI BRESCIA 
Via G. di Vittorio, 38 - Z.I. - 25128 Brescia
Tel. 030/3582734 - Fax 030/3582760
www.minettigroup.com - minettibrescia@minettigroup.com

S.I.R.I. SRL 
Via Dell'Industria 9 - 04011 Aprilia (LT)
Tel. 06/9206291 - Fax 06/9258643
www.sirisrl.com - info@sirisrl.com

SAROK ITALIA SRL 
Via Valsugana, 4 - 22053 Lecco (CO)
Tel. 0341/357811 - Fax 0341/283096
www.sarok.it - sarokitalia@sarok.it

SAROK DUE SRL 
Via 1 Maggio 9/11 - 20028 S. Vittore Olona (MI)
Tel. 0331/423911 - Fax 0331/423942
www.sarok.it - sarok2@tin.it

T.I.M. Tec.Ind. Modenesi 
Via Franz Leahr 25 - 41100 Modena
Tel. 059/282500 - Fax 059/282404
www.timmodena.com - timmodena@timmodena.com

TECHNOBI SRL 
Via Lazio, 65 - 20090 Buccinasco (MI)
Tel. 02/45712362 - Fax 02/45712219
www.technobi.it - technobi@libero.it

TECNICA INDUSTRIALE SRL 
S.P. 231 km1 ex SS.98 Km 80,176 - 70026 Modugno (BA)
Tel. 080/5367089 - 080/5367090 - Fax 080/5367091
www.tecnicaindustriale.it - info@tecnicaindustriale.it

TECNOFORNITURE SRL 
Via Pasubio 106 - 63037 Porto d'Ascoli (AP)
Tel. 0735/76171 - Fax 0735/655266
www.tecnoforniture.it - info@tecnoforniture.it

V.B. Moto Trasmissioni s.n.c. 
di Volpe E. E Bianchi P. E. C.
Via Enzo Ferrari 335 - 47037 Cesena (FO)
Tel. 0547/630610 - Fax 0547/630615
www.vbmototrasmissioni.it - info@vbmototrasmissioni.it

VENETA BEARINGS SRL 
Via Torino 15 - 35035 Mestrino (PD)
Tel. 049/9001944 - 049/9001549 - Fax 049/9001543
www.venetabearings.it - info@venetabearings.it

NEW ZEALAND 

SAECO BEARINGS TRANSMISSION
36 Hastie Avenue, MangerePo Box 22256, Otahuhu - Auckland
Tel. +64 9 634 7540 - Fax +64 9 634 7552
mark@saeco.co.nz

POLAND 

POLPACK Sp. z o.o. - Ul. Chrobrego 135/137 - 87100 Torun
Tel. 0048.56.6559235 - 6559236 - Fax 0048.56.6559238
www.polpack.com.pl - polpack@polpack.com.pl

RUSSIA 

FAM
57, Maly prospekt, V.O. - 199048, St. Petersburg
Tel. +7 812 3319333 - Fax +7 812 3271454
www.fam-drive.ru - info@fam-drive.ru

SPAIN

TECNOTRANS SABRE S.A.
Pol. Ind. Zona Franca sector C, calle F, nº6 08040 Barcelona
Tel. (+34) 93 4478400 - Fax (+34) 93 3360402
www.tecnotrans.com - tecnotrans@tecnotrans.com

SOUTH AFRICA

BONFIGLIOLI POWER TRANSMISSION Pty Ltd.
55 Galaxy Avenue, Limbro Business Park - Sandton
Tel. (+27) 11 608 2030 OR - Fax (+27) 11 608 2631
www.bonfiglioli.co.za - bonfigsales@bonfiglioli.co.za

SWEDEN

BONFIGLIOLI SKANDINAVIEN AB
Kontorsgatan - 234 34 Lomma
Tel. (+46) 40 412545 - Fax (+46) 40 414508
www.bonfiglioli.se - info@bonfiglioli.se

THAILAND 

K.P.T MACHINERY (1993) CO.LTD.
259/83 Soi Phiboonves, Sukhumvit 71 Rd. Phrakhanong-nur,
Wattana, Bangkok 10110
Tel. 0066.2.3913030/7111998
Fax 0066.2.7112852/3811308/3814905
www.kpt-group.com - sales@kpt-group.com

USA

BONFIGLIOLI USA INC
1000 Worldwide Boulevard - Hebron, KY 41048
Tel.: (+1) 859 334 3333 - Fax: (+1) 859 334 8888
www.bonfiglioliusa.com
industrialsales@bonfiglioliusa.com
mobilesales@bonfiglioliusa.com

VENEZUELA 

MAQUINARIA Y ACCESORIOS IND.-C.A.
Calle 3B - Edif. Comindu - Planta Baja - Local B
La Urbina - Caracas 1070
Tel. 0058.212.2413570 / 2425268 / 2418263
Fax 0058.212.2424552 - Tlx 24780 Maica V
www.maica-ve.com - maica@telcel.net.ve

HEADQUARTERS

BONFIGLIOLI RIDUTTORI S.p.A.
Via Giovanni XXIII, 7/A
40012 Lippo di Calderara di Reno
Bologna (ITALY)
Tel. (+39) 051 6473111
Fax (+39) 051 6473126
www.bonfiglioli.com
bonfiglioli@bonfiglioli.com

SPARE PARTS BONFIGLIOLI

B.R.T.
Via Castagnini, 2-4
Z.I. Bargellino - 40012
Calderara di Reno - Bologna (ITALY)
Tel. (+39) 051 727844
Fax (+39) 051 727066
www.brtonfiglioliricambi.it
brt@bonfiglioli.com

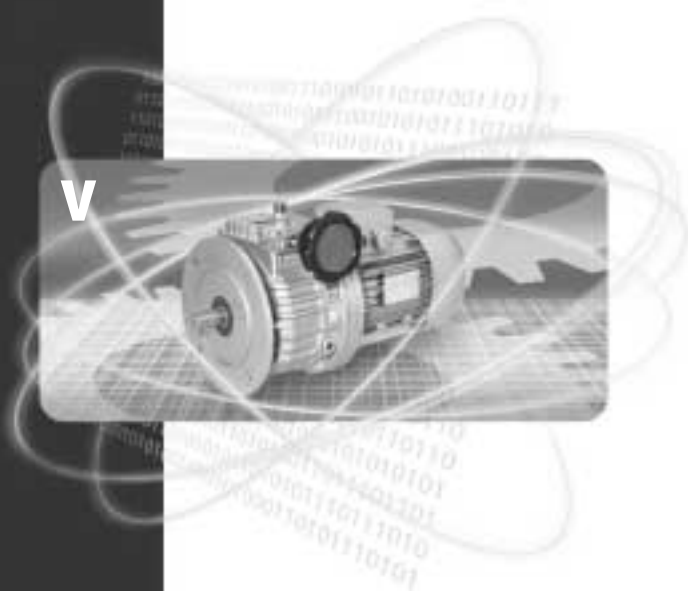

V

www.bonfiglioli.com

 **BONFIGLIOLI**