



The MVSI-E series has been designed for use in industrial processes in environments with a potentially explosive atmosphere, due to the presence of explosive gas and dust, in compliance with ATEX Directive (94/9/CE).

In particular, the MVSI-E series can be used in areas 1 and 2 (gas) and in areas 21 and 22 (dusts) according to the layout and following features:

Category: II 2 G,D

Level of protection: Ex e II, tD A21 IP66

Temperature class:
Gas: T3 (200°C) or T4 (135°C)
Dusts: see tab. page 36-43

EC certificate: LCIE 06 ATEX

Areas of use: 1, 2, 21, 22

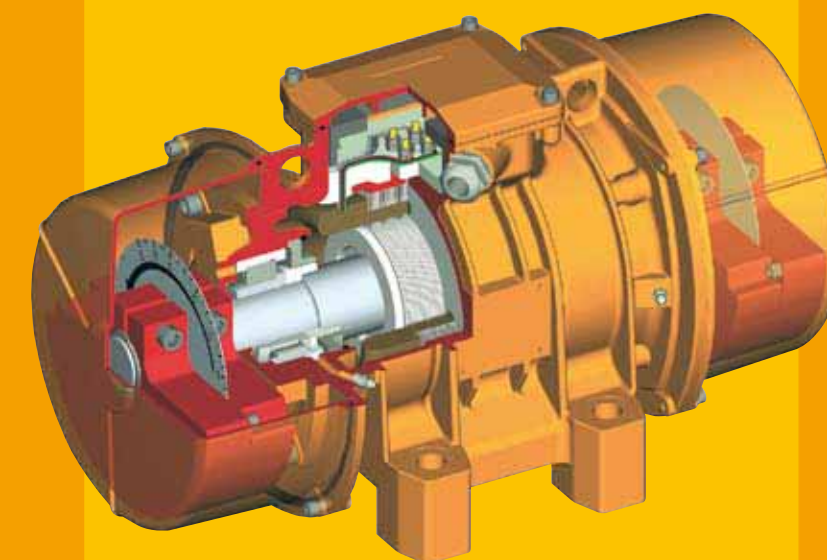

Technical features

Power supply

Three-phase voltage from 220V to 690V, 50Hz or 60Hz; suitable for use with an inverter from 20Hz to the base frequency with constant torque load profile.

Polarity

2, 4, 6 and 8 poles.

Conformity with European Directives

ATEX 94/9/CE; Electromagnetic Compatibility 89/336/CE.

Reference Regulations

IEC/EN 60079-0, IEC/EN 60079-7, IEC/EN 61241-0, IEC/EN 61241-1, EN 60034-1, EN 50081-1, EN 50081-2, EN 50082-1, EN 50082-2.

Controls

The components that affect protection are 100% accurately controlled and recorded. The vibrators undergo 100% dynamic tests on the bench.

Functioning

Continual service (S1) at maximum declared centrifugal force and electric power.

Centrifugal force

Range extended up to 9700 Kgf. (95 KN), adjustable in a continuous linear mode with variation of the position of the eccentric weight.

Mechanical protection

IP 66 according to IEC 529, EN 60529.

Shock-proof protection

IK 08 according to IEC 68, EN 50102.

Insulation class

Class F (155°C).

Tropicalization

Standard on all vibrators, with vacuum impregnation up to size AF 33 and 35, with "drop by drop" trickle system for larger sizes.

Environmental temperature

From -10°C to +40°C, on request it is possible to have vibrators for max. environmental temperatures of 55°C. On request special greases for temperatures lower than -10°C.

Vibrator heat protection

Standard PTC rated thermistor heat detectors 130°C (DIN 44081-44082) from size 70, on request for smaller sizes. On request, thermistors with different temperatures and anti-condensation heaters.

Fixing of the vibrator

In all positions and therefore without restriction.

Lubrication

All vibrators are lubricated in the factory and do not require further lubrication if used in normal operating conditions. In heavy duty operating conditions periodical re-lubrication may be applied to size 35 and larger.

Terminal box

Large fixed electrical connections. Special shaped terminals allow to fix the power supply cable, protecting it from loosening.

Electric motor

Three-phase asynchronous type. Designed for maximum starting torques and torque curves specific to requirements of vibrating machines. Insulated windings using vacuum encapsulating up to size 35; using the "drop by drop" trickle system with class H resin for larger sizes. The rotor is die cast aluminium.

Casing

In high-tensile aluminium alloy up to size 35, in ductile cast iron for larger sizes. Patented shape that improves heat dispersion and lowers normal working temperature at full load. An external earthing screw is located on the casing as prescribed by Regulation IEC/EN 60079-0.

Bearing flange

Constructed in cast iron (ductile or grey) or in aluminium with steel bearing seat. The geometry of the flange transmits the load to the casing uniformly.

Bearings

Custom made with particular geometry, especially designed for Italtvibras, suitable to support both high radial and axial loads.

Motor shaft

In treated steel alloy (Isothermic hardening) resistant to stress.

Eccentric weights

Allow continual adjustment of the centrifugal force. This adjustment is realized by a graduated scale, which expresses the centrifugal force as a percentage of the maximum centrifugal force. A patented system (patent N°MO98A000194), called ARS, prevents adjustment errors.

Weight covers

In aluminium alloy.

Painting

Electrostatic surface treatment based on polymerised epoxy polyester powder in oven at 200°C. Tested in salt spray for 500 hours.

Other features

The MVSI-E series is equipped with special cable holders in compliance with ATEX Ex e II Regulations and is characterized by two brass plates.

Certifications

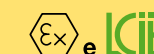

II 2 G, D – Class Ex e II T4/T3 tD A21 IP 66.
IEC/EN 60079-0, IEC/EN 60079-7,
IEC/EN 61241-0, IEC/EN 61241-1.
Certificate n° LCIE 06 ATEX



GGTN Permit and Gost-R certificate for increased safety Ex e:
GOST R 51330.0-99,
GOST R 51330.8-99, GOST R IEC 61241-1-1-99.



Comply with the applicable European Union directives

2 poles - 3000/3600 rpm

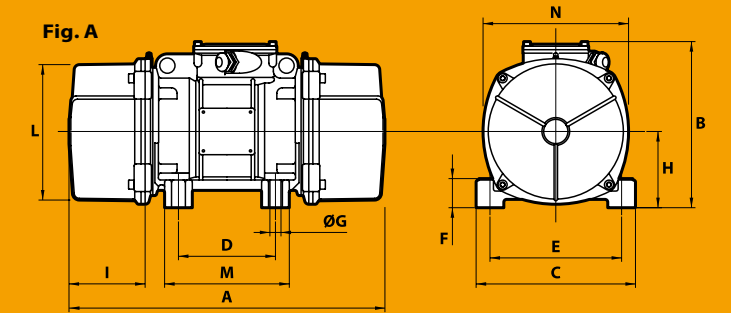

	Description			Mechanical specifications								Electrical specifications								Type	Dimensional specifications (mm)																
	Code	Type	SIZE	Static moment* kgmm		Centrifugal force				Weight kg		Temp. class (G)	Temp. class (D)	Max input power W		Power rating W		Max. current A			t _E (s)	I _a /I _n	Fig.	A	B	C	D	E	Holes		F	H	I	L	M	N	Cable entry thread
				50 Hz	60 Hz	50 Hz	60 Hz	50 Hz	60 Hz	50 Hz	60 Hz			50 Hz	60 Hz	400 V 50 Hz	460 V 60 Hz	400 V 50 Hz	460 V 60 Hz										øG	N*							
three-phase	6E0311	MVSI 3/100E-S02 ▲	00	12.0	12.0	121	174	1.19	1.71	5.60	5.60	T3 T4	120°C	180 105	180 105	120 80	120 80	0.33 0.26	0.30 0.23	30 20	2.68 3.48	MVSI 3/100E-S02 ▲	A	211	153	125	62-74**	106	9	4	24	61	46	103	100	117	M20x1,5
	6E0312	MVSI 3/200E-S02 ▲	01	21.0	15.0	211	218	2.07	2.14	6.40	6.20	T3	120°C	180	180	120	120	0.33	0.30	30	2.68	MVSI 3/200E-S02 ▲	A	235	153	125	62-74**	106	9	4	24	61	58	103	100	117	M20x1,5
	6E0313	MVSI 3/300E-S02	10	30.1	20.4	304	297	2.98	2.91	9.70	9.20	T3 T4	120°C	260 230	270 230	210 172	210 172	0.57 0.48	0.50 0.41	18 12	3.50 4.20	MVSI 3/300E-S02	A	255	179	152	90	125	13	4	28	73	54	127	128	141	M20x1,5
	6E0314	MVSI 3/500E-S02	20	49.9	32.4	503	471	4.93	4.62	14.8	13.8	T3 T4	120°C	500 350	500 360	300 210	300 210	0.76 0.57	0.67 0.50	12 8	4.20 5.60	MVSI 3/500E-S02	A	288	203	167	105	140	13	4	30	82.5	65	145	140	160	M25x1,5
	6E0382	MVSI 3/800E-S02	30	78.0	52.0	785	754	7.70	7.40	16.8	15.9	T3 T4	120°C	550 390	570 400	405 290	405 290	0.95 0.72	0.83 0.64	12 8	4.20 5.52	MVSI 3/800E-S02	A	308	216	205	120	170	17	4	45	93.5	63	170	160	182	M25x1,5
	6E0222	MVSI 3/1100E-S90	35	110	73.0	1105	1061	10.8	10.4	23.0	22.0	T3 T4	120°C	550 460	600 500	350 290	350 290	0.86 0.76	0.75 0.67	15 11	3.88 4.37	MVSI 3/1100E-S90	A	372	233	205	120	170	17	4	54	104.5	86	187	162	203	M25x1,5
	6E0243	MVSI 3/1310E-S90	AF33	128	91.6	1290	1327	12.7	13.0	31.0	29.7	T4	200°C	700	750	500	500	1.24	1.07	6	6.40	MVSI 3/1310E-S90	A	355	213.5	215	100	180	17	4	47	92.5	81.5	164	140	179	M25x1,5
	6E0254	MVSI 3/1510E-S90	AF50	153	102	1545	1483	15.2	14.5	39.5	38.0	T3 T4	200°C	1010 830	1070 910	720 660	720 660	1.62 1.43	1.40 1.25	6 6	9.29 7.30	MVSI 3/1510E-S90	A	430	230	230	140	190	17	4	49	104	87.5	186	180	200	M25x1,5
	6E0255	MVSI 3/1810E-S90	AF50	179	128	1802	1853	17.7	18.2	40.5	39.0	T3	200°C	1010	1070	720	720	1.62	1.40	6	9.29	MVSI 3/1810E-S90	A	430	230	230	140	190	17	4	49	104	87.5	186	180	200	M25x1,5
	6E0256	MVSI 3/2010E-S90	AF50	205	128	2059	1853	20.2	18.2	48.7	46.3	T3	200°C	1110	1150	960	960	1.90	1.66	7	5.90	MVSI 3/2010E-S90	A	465	230	230	140	190	17	4	49	104	105	186	180	200	M25x1,5
	6E0257	MVSI 3/2310E-S90	AF50	230	153	2316	2224	22.7	21.8	49.6	47.1	T3	200°C	1110	1150	960	960	1.90	1.66	7	5.90	MVSI 3/2310E-S90	A	465	230	230	140	190	17	4	49	104	105	186	180	200	M25x1,5
	6E0200	MVSI 3/5010E-S90	AF70	515	344	5187	4979	50.9	48.8	109	105	T3	135°C	3000	3000	2600	2600	4.75	4.20	5	8.00	MVSI 3/5010E-S90	A	558	304	310	155	255	25	4	90	130	108	233	210	248	M32x1,5

* Working moment = 2 x static moment. ** Slot. ▲ Available only in versions 127/220V 50Hz three-phase, 200/346V 60Hz three-phase and 210/363V 60Hz three-phase.

t_E (s) = set time t_E from IEC/EN 60079-7. I_a/I_n = ratio between start-up current and maximum current.

4 poles - 1500/1800 rpm

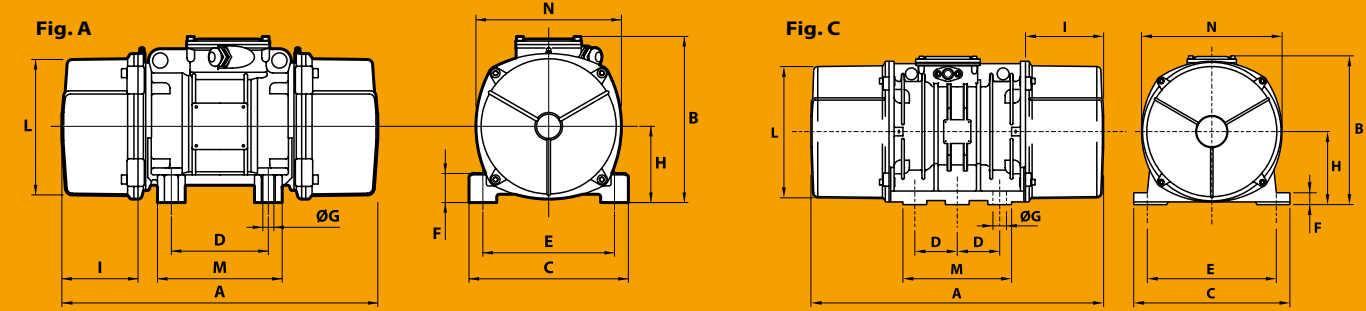

	Description			Mechanical specifications								Electrical specifications								Type	Dimensional specifications (mm)																
	Code	Type	SIZE	Static moment* kgmm		Centrifugal force				Weight kg		Temp. class (G)	Temp. class (D)	Max input power W		Power rating W		Max. current A			t _E (s)	I _a /I _n	Fig.	A	B	C	D	E	Holes				I	L	M	N	Cable entry thread
				50 Hz	60 Hz	50 Hz	60 Hz	50 Hz	60 Hz	50 Hz	60 Hz			50 Hz	60 Hz	400 V 50 Hz	460 V 60 Hz	400 V 50 Hz	460 V 60 Hz										400 V 50 Hz	460 V 60 Hz	øG	N°					
three-phase	6E1367	MVSI 15/200E-S02	10	84.2	58.8	213	214	2.09	2.10	12.5	11.7	T4	120°C	170	175	94	95	0.39	0.40	28	2.34	MVSI 15/200E-S02	A	301	179	152	90	125	13	4	28	73	77	127	128	141	M20x1,5
	6E1372	MVSI 15/400E-S02	20	163	113	412	411	4.04	4.03	19.0	18.2	T3 T4	120°C	300 285	320 270	200 180	230 200	0.57 0.52	0.52 0.46	18 16	3.33 3.63	MVSI 15/400E-S02	A	344	203	167	105	140	13	4	30	82.5	93	145	140	160	M25x1,5
	6E1373	MVSI 15/550E-S02	20	219	163	552	592	5.42	5.81	20.4	19.0	T3 T4	120°C	300 285	320 270	200 180	230 200	0.57 0.52	0.52 0.46	18 16	3.33 3.63	MVSI 15/550E-S02	A	386	203	167	105	140	13	4	30	82.5	114	145	140	160	M25x1,5
	6E1408	MVSI 15/700E-S02	30	286	209	720	760	7.06	7.46	23.5	22.2	T3 T4	120°C	460 360	500 420	310 240	380 310	0.86 0.72	0.85 0.70	17 12	3.5 4.2	MVSI 15/700E-S02	A	394	216	205	120	170	17	4	45	93.5	106	170	160	182	M25x1,5
	6E1201	MVSI 15/1100E-S90	35	415	271	1045	982	10.3	9.63	35.0	30.5	T4	120°C	370	450	285	340	0.81	0.83	13	4	MVSI 15/1100E-S90	A	435	233	205	120	170	17	4	54	104.5	117.5	187	162	203	M25x1,5
	6E1217	MVSI 15/1410E-S90	40	561	400	1413	1449	13.9	14.2	53.0	50.0	T3 T4	120°C	900 630	950 700	660 460	730 505	1.38 1.05	1.32 1.00	13 8	4 5.36	MVSI 15/1410E-S90	A	448	246	230	140	190	17	4	54	116	108	210	180	225	M25x1,5
	6E1219	MVSI 15/1710E-S90	50	715	485	1798	1757	17.6	17.2	57.0	54.5	T3 T4	150°C	1100 630	1150 700	730 480	800 530	1.90 1.33	1.82 1.27	9 5.5	4.95 7	MVSI 15/1710E-S90	A	500	246	230	140	190	17	4	54	116	134	210	180	225	M25x1,5
	6E1267	MVSI 15/2000E-S90	50	817	561	2054	2033	20.1	19.9	61.5	57.5	T3 T4	170°C	1100 630	1150 700	730 480	800 530	1.90 1.33	1.82 1.27	9 5.5	4.95 7	MVSI 15/2000E-S90	A	568	246	230	140	190	17	4	54	116	168	210	180	225	M25x1,5
	6E1220	MVSI 15/2410E-S02	60	962	674	2420	2444	23.7	24.0	81.0	76.0	T3 T4	150°C	1600 1150	1700 1250	1340 880	1470 970	3.04 2.47	3.20 2.30	7 5.5	6 7.5	MVSI 15/2410E-S02	A	537	278	275	155	225	22	4	70	135	137	238	205	253	M25x1,5
	6E1268	MVSI 15/3000E-S02	60	1235	858	3106	3107	30.5	30.5	90.0	83.5	T3 T4	135°C	1280 1150	1550 1400	1000 900	1200 1080	3.14 2.85	3.10 2.85	5.5 5.5	7.42 8.16	MVSI 15/3000E-S02	A	617	278	275	155	225	22	4	70	135	177	238	205	253	M25x1,5
	6E1221	MVSI 15/3810E-S02	70	1526	1034	3840	3744	37.7	36.7	119	110	T3 T4	135°C	2200 1850	2400 1950	1780 1500	1960 1650	3.71 3.14	3.50 3.00	6 6	7.17 8.42	MVSI 15/3810E-S02	A	584	321	310	155	255	23.5	4	77	157	137	280	215	295	M25x1,5
	6E1269	MVSI 15/4300E-S02	70	1720	1173	4326	4250	42.4	41.7	123	117	T3 T4	135°C	2200 1850	2400 1950	1780 1500	1960 1650	3.71 3.14	3.50 3.00	6 6	7.17 8.42	MVSI 15/4300E-S02	A	666 (50Hz) 584 (60Hz)	321	310	155	255	23.5	4	77	157	178 (50Hz) 137 (60Hz)	280	215	295	M25x1,5
	6E1211	MVSI 15/5010E-S02	80	1990	1364	5007	4911	49.1	48.5	161	153	T3	135°C	3200	3700	2560	2800	5.70	5.45	6	7	MVSI 15/5010E-S02	A	630	347	340	180	280	26	4	80	165	150	303	240	320	M32x1,5
	6E1204	MVSI 15/9500E-S02	97	3346	2462	8416	8916	82.6	87.5	317	303	T3	135°C	7300	7900	5925	6500	11.6	11.0	5.5	7	MVSI 15/9500E-S02	C	862	437	460	125	380	38	6	35	215	230	387	320	414	M32x1,5

* Working moment = 2 x static moment.

t_E (s) = set time t_E from IEC/EN 60079-7. I_a/I_n = ratio between start-up current and maximum current.

6 poles - 1000/1200 rpm

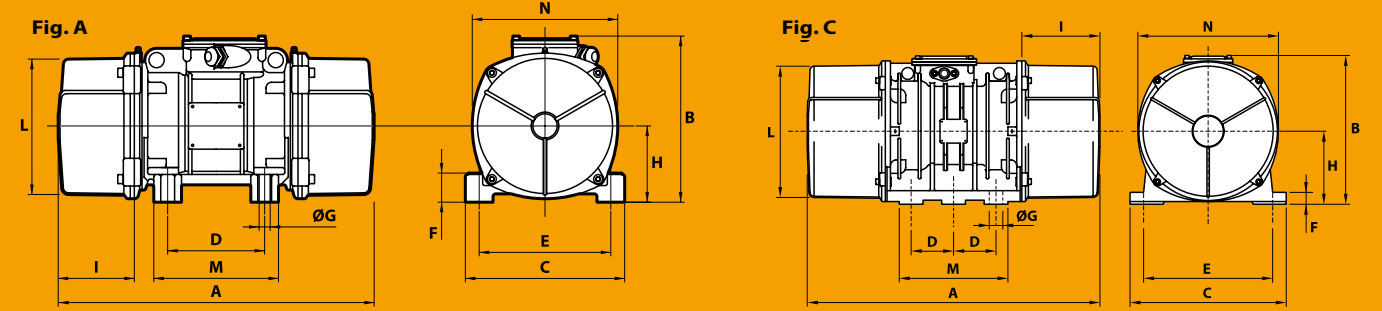

	Description			Mechanical specifications						Electrical specifications						Dimensional specifications (mm)																					
	Code	Type	SIZE	Static moment* kgmm		Centrifugal force				Weight kg		Temp. class (G)	Temp. class (D)	Max input power W		Power rating W		Max. current A		tE (s)	Ia/In	Type	Fig.	A	B	C	D	E	Holes				I	L	M	N	Cable entry thread
				50 Hz	60 Hz	50 Hz	60 Hz	50 Hz	60 Hz	50 Hz	60 Hz			50 Hz	60 Hz	400 V 50 Hz	460 V 60 Hz	400 V 50 Hz	460 V 60 Hz										400 V 50 Hz	460 V 60 Hz	øG	N°					
three-phase	6E2298	MVSI 10/200E-S02	20	163	163	183	264	1.80	2.59	19.0	19.0	T4	120°C	185	200	100	110	0.48	0.45	25	2.72	MVSI 10/200E-S02	A	344	203	167	105	140	13	4	30	82.5	93	145	140	160	M25x1,5
	6E2314	MVSI 10/310E-S02	30	286	209	321	338	3.15	3.32	23.5	22.2	T4	120°C	320	350	201	221	0.67	0.65	25	2.81	MVSI 10/310E-S02	A	394	216	205	120	170	17	4	45	93.5	106	170	160	182	M25x1,5
	6E2150	MVSI 10/550E-S90	35	457	457	512	737	5.02	7.23	36.5	36.5	T4	120°C	350	380	240	264	0.71	0.68	26	2.40	MVSI 10/550E-S90	A	435	233	205	120	170	17	4	54	104.5	117.5	187	162	203	M25x1,5
	6E2161	MVSI 10/810E-S90	40	723	561	809	905	7.94	8.88	54.0	50.0	T3 T4	135°C	680 500	730 540	448 290	490 320	1.33 1.05	1.27 1.00	25 17	2.78 3.54	MVSI 10/810E-S90	A	500 (50Hz) 448 (60Hz)	246	230	140	190	17	4	54	116	134 (50Hz) 108 (60Hz)	210	180	225	M25x1,5
	6E2162	MVSI 10/1110E-S90	50	1012	715	1132	1151	11.1	11.3	64.0	57.0	T3 T4	135°C	750 480	690 500	550 300	550 300	1.57 1.24	1.36 1.00	19 13	3.33 4.23	MVSI 10/1110E-S90	A	568 (50Hz) 500 (60Hz)	246	230	140	190	17	4	54	116	168 (50Hz) 134 (60Hz)	210	180	225	M25x1,5
	6E2228	MVSI 10/1400E-S90	50	1274	904	1424	1483	14.0	14.5	78.0	71.0	T3 T4	170°C	750 480	690 500	550 300	550 300	1.57 1.24	1.36 1.00	19 13	3.33 4.23	MVSI 10/1400E-S90	A	568	246	230	140	190	17	4	54	116	168	210	180	225	M25x1,5
	6E2165	MVSI 10/1610E-S02	60	1464	962	1638	1549	16.1	15.2	93.0	81.0	T3 T4	135°C	1100 850	1200 950	825 615	900 675	2.09 1.81	2.00 1.70	15 10	3.63 4.73	MVSI 10/1610E-S02	A	617 (50Hz) 537 (60Hz)	278	275	155	225	22	4	70	135	177 (50Hz) 137 (60Hz)	238	205	253	M25x1,5
	6E2229	MVSI 10/2100E-S02	60	1927	1318	2154	2102	21.1	20.6	105	92.0	T3 T4	200°C	1500 1050	1700 1200	940 750	1020 820	2.85 2.19	2.75 2.10	9 8	4.50 4.89	MVSI 10/2100E-S02	A	617 (50Hz) 537 (60Hz)	278	275	155	225	22	4	70	135	177 (50Hz) 137 (60Hz)	238	205	253	M25x1,5
	6E2167	MVSI 10/2610E-S02	70	2326	1706	2601	2747	25.5	26.9	130	116	T3	135°C	1960	2100	1580	1700	3.90	3.70	8	5.31	MVSI 10/2610E-S02	A	666	321	310	155	255	23.5	4	77	157	178	277	215	295	M25x1,5
	6E2230	MVSI 10/3000E-S02	70	2690	1940	3007	3124	29.5	30.6	145	130	T3 T4	135°C	2200 1770	2400 1900	1630 1350	1770 1470	4.28 3.71	4.30 3.60	8 5	4.82 5.56	MVSI 10/3000E-S02	A	706	321	310	155	255	23.5	4	77	157	198	277	215	295	M25x1,5
	6E2154	MVSI 10/3810E-S02	80	3422	2380	3826	3831	37.5	37.6	188	170	T3 T4	135°C	2200 2000	2700 2200	1575 1500	1730 1650	4.85 4.28	4.60 4.00	7 6	5.88 6.66	MVSI 10/3810E-S02	A	730	347	340	180	280	26	4	80	165	200	303	240	320	M32x1,5
	6E2204	MVSI 10/4700E-S02	80	4206	2887	4701	4648	46.1	46.0	204	183	T3 T4	135°C	3100 2550	3500 3000	2500 2100	2770 2290	6.18 5.42	6.00 5.20	10 6	5.23 5.96	MVSI 10/4700E-S02	A	796	347	340	180	280	26	4	80	165	233	303	240	320	M32x1,5
	6E2138	MVSI 10/5200E-S02	90	4658	3288	5208	5293	51.1	51.9	238	215	T3	135°C	3500	3650	2590	2700	6.65	6.10	10	4.64	MVSI 10/5200E-S02	A	740	370	390	200	320	28	4	90	180	190	330	270	350	M32x1,5
	6E2136	MVSI 10/6600E-S02	97	6083	3979	6799	6405	66.7	62.8	285	257	T3	135°C	4200	4800	3360	3550	7.60	7.00	5.3	6.67	MVSI 10/6600E-S02	C	750	437	460	125	380	38	6	35	215	174	387	320	414	M32x1,5
	6E2137	MVSI 10/10000E-S02	97	8673	5664	9695	9117	95.1	89.4	381	340	T3	135°C	5400	5900	4500	4800	9.98	9.10	7	6.00	MVSI 10/10000E-S02	C	862	437	460	125	380	38	6	35	215	230	387	320	414	M32x1,5

* Working moment = 2 x static moment.

tE (s) = set time tE from IEC/EN 60079-7. Ia/In = ratio between start-up current and maximum current.

8 poles - 750/900 rpm

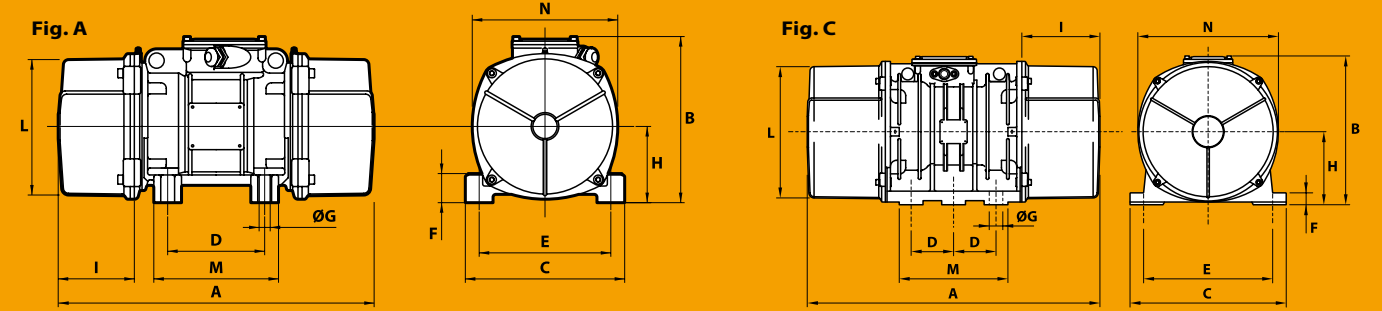

	Description			Mechanical specifications						Electrical specifications						Type	Dimensional specifications (mm)																				
	Code	Type	SIZE	Static moment* kgmm		Centrifugal force				Weight kg		Temp. class (G)	Temp. class (D)	Max input power W			Power rating W		Max. current A		tE (s)	Ia/In	Fig.	A	B	C	D	E	Holes		F	H	I	L	M	N	Cable entry thread
				50 Hz	60 Hz	50 Hz	60 Hz	50 Hz	60 Hz	50 Hz	60 Hz			50 Hz	60 Hz		400 V 50 Hz	460 V 60 Hz	400 V 50 Hz	460 V 60 Hz									øG	N°							
three-phase	6E2568	MVSI 075/150E-S02	20	163	163	104	149	1.02	1.46	19.0	19.0	T3	130°C	230	250	100	110	0.67	0.64	25	2.00	MVSI 075/150E-S02	A	344	203	167	105	140	13	4	30	82.5	93	145	140	160	M25x1,5
	6E2575	MVSI 075/250E-S02	30	286	286	181	260	1.76	2.55	23.5	23.5	T3	130°C	350	350	190	205	0.86	0.80	25	2.47	MVSI 075/250E-S02	A	394	216	205	120	170	17	4	45	93.5	106	170	160	182	M25x1,5
	6E2865	MVSI 075/400E-S90	35	457	457	288	415	2.83	4.07	36.5	36.5	T4	120°C	280	300	135	150	0.57	0.56	30	1.66	MVSI 075/400E-S90	A	435	233	205	120	170	17	4	54	104.5	117.5	187	162	203	M25x1,5
	6E2888	MVSI 075/660E-S90	40	723	723	456	656	4.47	6.44	54.0	54.0	T3	120°C	500	525	275	302	1.14	1.10	30	2.15	MVSI 075/660E-S90	A	500	246	230	140	190	17	4	54	116	134	210	180	225	M25x1,5
	6E2889	MVSI 075/910E-S90	50	1012	1012	637	917	6.25	9.00	64.0	64.0	T3 T4	120°C	600 450	670 500	336 225	380 255	1.33 1.14	1.30 1.10	30 25	2.14 2.50	MVSI 075/910E-S90	A	568	246	230	140	190	17	4	54	116	168	210	180	225	M25x1,5
	6E2890	MVSI 075/1310E-S02	60	1464	1464	922	1327	9.04	13.0	93.0	93.0	T3	150°C	950	1100	646	740	2.09	2.10	30	2.63	MVSI 075/1310E-S02	A	617	278	275	155	225	22	4	70	135	177	238	205	253	M25x1,5
	6E2891	MVSI 075/2110E-S02	70	2326	2326	1463	2107	14.4	20.7	130	130	T3	135°C	1500	1650	1065	1225	3.61	3.60	15	4.18	MVSI 075/2110E-S02	A	666	321	310	155	255	23.5	4	77	157	178	280	215	295	M25x1,5
	6E2884	MVSI 075/3110E-S02	80	3421	3421	2152	3099	21.1	30.4	188	188	T3	135°C	2000	2200	1460	1600	5.13	5.00	13	3.96	MVSI 075/3110E-S02	A	734	347	340	180	280	26	4	80	165	202	303	240	320	M32x1,5
	6E2515	MVSI 075/3800E-S02	80	4206	4206	2645	3808	25.9	37.4	204	204	T3	135°C	2500	3000	1800	2100	5.70	6.00	14	4.00	MVSI 075/3800E-S02	A	796	347	340	180	280	26	4	80	165	233	303	240	320	M32x1,5
	6E2862	MVSI 075/4200E-S02	90	4658	4658	2930	4218	28.7	41.4	238	238	T3	135°C	2630	2990	1900	2180	6.18	6.20	14	3.84	MVSI 075/4200E-S02	A	740	370	390	200	320	28	4	90	180	190	330	270	350	M32x1,5
	6E2826	MVSI 075/5300E-S02	90	5838	5838	3672	5287	36.0	51.9	268	268	T3	135°C	3520	3800	2570	2775	7.79	7.40	14	3.80	MVSI 075/5300E-S02	A	840	370	390	200	320	28	4	90	180	240	330	270	350	M32x1,5
	6E2870	MVSI 075/10000E-S02	97	12390	10973	7792	9937	76.4	97.5	438	419	T3	135°C	5100	5800	4100	4500	11.4	11.0	17	3.50	MVSI 075/10000E-S02	C	1002	437	460	125	380	38	6	35	215	300	387	320	414	M32x1,5

* Working moment = 2 x static moment.

tE (s) = set time tE from IEC/EN 60079-7. Ia/In = ratio between start-up current and maximum current.