

MICRO

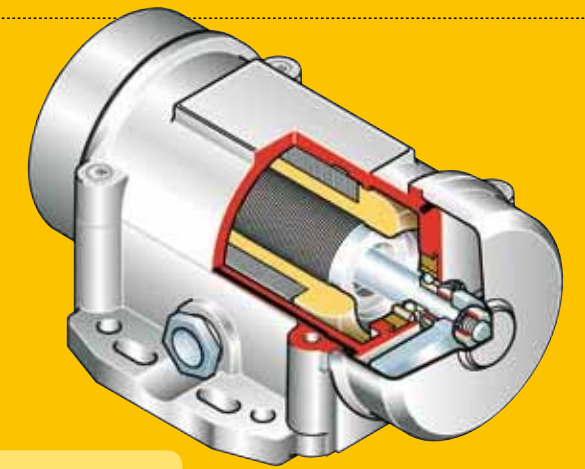

The MICRO series has been designed for continual industrial service in processes where a reduced centrifugal force and reduced overall vibrator size are required. MICRO vibrators are used in numerous

applications in feeding, transport, screening, sizing, separation processes, compaction in the automatic machines used in the chemical industry, food industry, pharmaceuticals, packaging and automation in general.



Technical features

Power supply

Three-phase voltage from 24V to 480V, 50Hz or 60Hz or single phase 100-130V, 60Hz and 200-240V, 50Hz (in the standard single-phase version, the capacitor is already included in a case along the power supply cable); suitable for use with an inverter from 20 to 60Hz to the base frequency with constant torque load profile.

Polarity

2 poles.

Conformity with European Directives

Low voltage 73/23/CE; Electromagnetic Compatibility 89/336/CE.

Reference Regulations

EN 60034-1, EN 50081-1, EN 50081-2, EN 50082-1, EN 50082-2.

Functioning

Continual service (S1) at maximum declared centrifugal force and electric power. Intermittent services are also possible depending on the type of vibrator and the operating conditions. For detailed information contact our technical assistance office.

Centrifugal force

Range extended to 65 Kgf. (63.8 KN), with centrifugal force adjustable from 0 to 100%.

Mechanical protection

IP 65 according to IEC 529, EN 60529.

Insulation class

Class F (155°C).

Tropicalization

Standard on all vibrators.

Environmental temperature

From -30°C to +40°C.

Fixing of the vibrator

In all positions and therefore without restriction.

Lubrication

All vibrators are lubricated in the factory and do not require further lubrication if used in normal operating conditions.

Electric motor

Three-phase and single-phase asynchronous type. The M3/4 model can only be supplied in the single-phase version and does not require a capacitor. Models M3/20 and M3/45 can be supplied both in three-phase and single-phase versions. The capacitor is already included in a case along the power supply cable.

Casing

In high-tensile light aluminium alloy with polished surface.

Eccentric weights

Thin plate-type, allow step-by-step adjustment through variation of the number of weights mounted or their rotation.

Weight covers

In stainless steel AISI 304.

Other features

All Micro series standard models are supplied with a 2-meter power supply cable and, in the models requiring it, a capacitor inserted into a special enclosure in-line with the cable. CSA certification can be supplied on request. The supplied product is not equipped with a capacitor (neither along the cable nor in other positions), therefore the user must install one as per Standard.

Certifications



Regulation CAN/CSA - C22.2 N. 100-95, file n° LR100948 Class 4211 01 - Motors and generators.



Gost-R certificate for all models of vibrators: GOST 16264.1, GOST 16264.0, GOST R 51689.



Comply with the applicable European Union directives

Fig. N

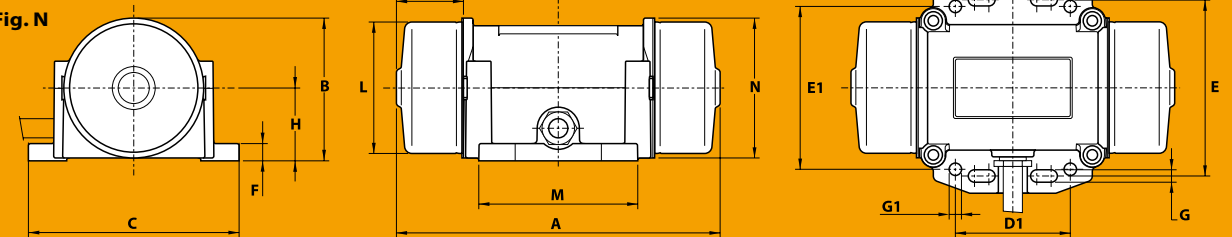

	Description			Mechanical specifications					Electrical specifications			Dimensional specifications (mm)																			
	Code	Type	IP	rpm		Centrifugal force kg		Weight kg	Max input power W	Max. current A	Type	Fig.	A	B	C	D	D1	E	E1	F	G	øG1	N°	H	I	L	M	N	Cable entry thread		
three-phase	600290	M3/4	□	50 Hz	60 Hz	50 Hz	60 Hz	50 Hz	50 Hz	380/480 V	M3/4	N	113	62.5	90	25-40	-	75	-	9	5.5	-	4	32	20	56.6	59	61	M12x1.5		
	600291	M3/20	□	3000	3600	20	29	1.97	35	0.15	M3/20	N	154	74.5	110	25-40	60	92	85	9	6.5	6.5	8	38	27.5	68.6	83	73	M16x1.5		
	600292	M3/45	□	3000	3600	45	65	2.20	45	0.16	M3/45	N	169	74.5	110	25-40	60	92	85	9	6.5	6.5	8	38	35	68.6	83	73	M16x1.5		
single-phase	600290	M3/4	□	220 V	3000	3600	4	6	0.92	24	0.13	0.30	M3/4	N	113	62.5	90	25-40	-	75	-	4	32	20	56.6	59	61	M12x1.5			
	600291	M3/20	□	50 Hz	3000	3600	20	29	1.97	35	0.17	0.42	M3/20	N	154	74.5	110	25-40	60	92	85	9	6.5	6.5	8	38	27.5	68.6	83	73	M16x1.5
	600292	M3/45	□	60 Hz	3000	3600	45	65	2.20	45	0.20	0.46	M3/45	N	169	74.5	110	25-40	60	92	85	9	6.5	6.5	8	38	35	68.6	83	73	M16x1.5

* The CSA version can be supplied on request and does not envision supply of the condenser.