

# MVB / MVB-FLC



The MVB series is made up of vertical vibrators with lateral flange and shaft projecting on both sides.

The MVB-FLC series is made up of vertical vibrators with central flange and shaft projecting on both sides.

These vibrators are typically used in circular screens and medium-size and large sieves, and can be supplied in 4 different versions: A, B, C, D (see page 82) according to the type of eccentric weights supplied with the vibrator and which must be mounted by the user. Size 50 is only available in B, C and D versions.

The size 50 complies with the most recent IEC and EN international standards for use in atmospheres with potentially explosive powders. In particular, the size 50 series can be used in areas 21 and 22.

**Type:** MVB SIZE.50, MVB-FLC SIZE.50

**Category:** II 2 D

**Level of protection:** tD A21 IP66

**Temperature class:** 150°C

**EC certificate:** LCIE 05 ATEX 6163 X

**Areas of use:** 21, 22

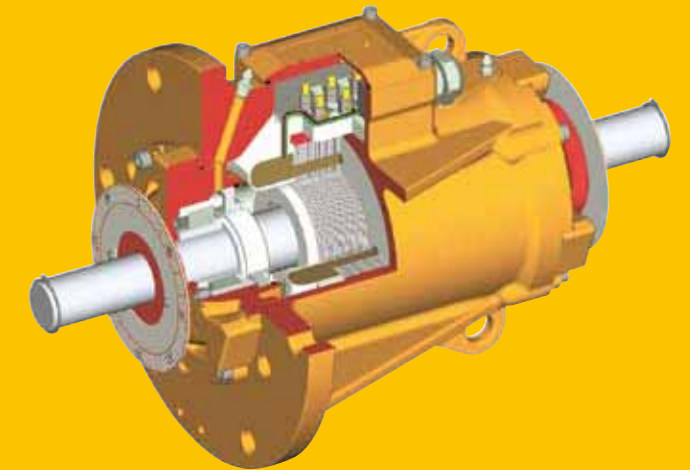

## Technical features

### Power supply

Three-phase voltage from 220V to 690V, 50Hz or 60Hz; suitable for use with an inverter from 20Hz to the base frequency with constant torque load profile.

### Polarity

4 poles.

### Conformity with European Directives

Low voltage 73/23/CE; Electromagnetic Compatibility 89/336/CE (only size 50)

### Reference Regulations

EN 60034-1, EN 50081-1, EN 50081-2, EN 50082-1, EN 50082-2, IEC/EN 61241-0, IEC/EN 61241-1

### Functioning

Continual service (S1) at maximum declared centrifugal force and electric power. Intermittent services are also possible depending on the type of vibrator and the operating conditions. For detailed information, contact our technical assistance office.

### Centrifugal force

Range extended up to 7000 Kgf. (68.7 KN), with centrifugal force adjustable from 0 to 100%.

### Mechanical protection

IP 66 according to IEC 529, EN 60529.

### Shock-proof protection

IK 08 according to IEC 68, EN 50102.

### Insulation class

Class F (155°C), class H (180°C) on request.

### Tropicalization

Standard on all vibrators with "drop by drop" trickle system.

### Environmental temperature

From -30°C a +40°C. Versions for higher or lower temperatures are available on request.

### Vibrator heat protection

Standard PTC rated thermistor heat detectors 130°C (DIN 44081-44082) from size 80, on request for smaller sizes. Also on request thermistors with different temperatures and anti-condensation heaters.

### Fixing of the vibrator

In all positions and therefore without restriction.

### Lubrication

All vibrators are lubricated in the factory and do not require further lubrication if used in normal operating conditions. In heavy duty operating conditions periodical re-lubrication may be applied.

### Terminal box

Large fixed electrical connections. Special shaped terminals allow to fix the power supply cable, protecting it from loosening.

### Electric motor

Three-phase asynchronous type. Designed for maximum starting torques and torque curves specific to requirements of vibrating machines. Insulated windings using "drop by drop" trickle system with class H resin. The rotor is die cast aluminium.

### Casing

In ductile cast iron to have high strength and optimal elasticity.

### Bearing flange

Constructed in ductile cast iron. The geometry of the flange transmits the load to the casing uniformly.

### Bearings

Custom made with particular geometry, especially designed for Italtvibras, suitable to support both high radial and axial loads.

### Motor shaft

In treated steel alloy (Isothermic hardening) resistant to stress.

### Eccentric weights

Lamellar for clamped centric weight have an ample possibility of adjustment: the particular adjustment system adopted allows to obtain phase shift from 0 to 180° of the group of upper weights with respect to the group of lower weights and to have ample adjustment of the centrifugal force within the same group of weights.

### Weight covers

Not envisioned in the MVB and MVB-FLC series.

### Painting

Electrostatic surface treatment based on polymerised epoxy polyester powder in oven at 200°C. Tested in salt spray for 500 hours.

## Certifications



Regulation CAN/CSA - C22.2 N. 100-95, file n° LR100948 Class 4211 01 – Motors and generators.



Mechanical protection IP66 (EN 60529), shock-proof protection IK 08 (EN 50102)



II 2 D, tD A21 IP66 IEC/EN 61241-0, IEC/EN 61241-1 Certificate n. LCIE 05 ATEX 6163X



Gost-R certificate for all models of vibrators: GOST 16264.1, GOST 16264.0, GOST R 51689.



Comply with the applicable European Union directives



## MVB 4 poles - 1500/1800 rpm

	Description					Mechanical specifications				Electrical specifications				Type	Dimensional specifications (mm)																
	Code	Type	SIZE	SF	II2D Temp. class	Centrifugal force				Max input power		Max. current			Ia/In		Fig.	A	øB	øC	øD	Holes		E	F	G	øI	L	M	Cable entry thread	
						50 Hz	60 Hz	50 Hz	60 Hz	kg	kN	Weight kg	50 Hz		60 Hz	400 V 50 Hz						460 V 60 Hz	50 Hz								60 Hz
three-phase	601226	MVB 1510/15	50	•	150°C	1500	1500	14.7	14.7	41.5	1100	1200	2.10	2.00	3.76	4.50	MVB 1510/15	I	476	290	171	250	17	6	278	46	20	35	71	71	M25x1,5
	601129	MVB 2500/15	60	•	/	2500	2500	24.5	24.5	67.0	2150	2700	3.90	4.10	5.60	5.81	MVB 2500/15	I	587	350	224	305	21	6	294	54	27	40	71	71	M25x1,5
	601130	MVB 4500/15	80	•	/	4500	4500	44.1	44.1	106	4000	4200	6.70	5.80	4.48	4.18	MVB 4500/15	I	664	400	240	355	23.5	6	340	70	30	52	75	75	M25x1,5
	601131	MVB 7000/15	90	•	/	7000	7000	68.7	68.7	160	7000	7000	11.8	10.2	6.19	6.73	MVB 7000/15	I	740	508	314	438	25	8	388	88	34	52	79	79	M32x1,5

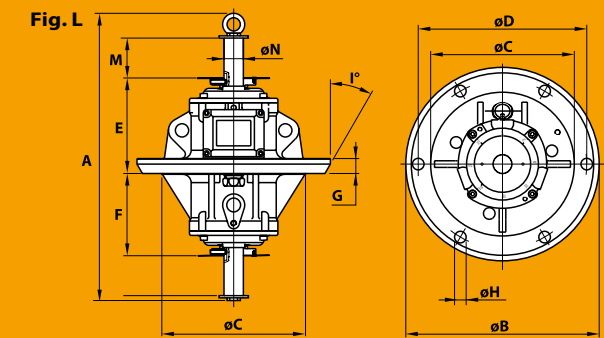
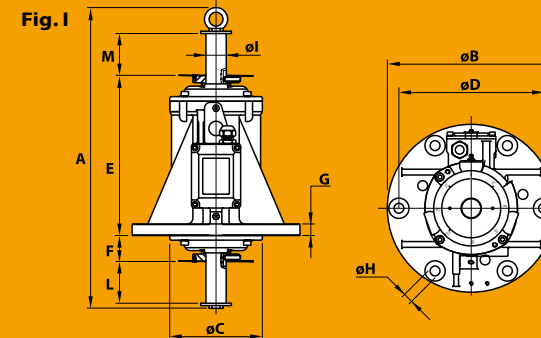

## MVB-FLC 4 poles - 1500/1800 rpm

	Description					Mechanical specifications				Electrical specifications				Type	Dimensional specifications (mm)																	
	Code	Type	SIZE	SF	II2D Temp. class	Centrifugal force				Max input power		Max. current			Ia/In		Fig.	A	øB	øC	øD	Holes		E	F	G	I'	L	M	øN	Cable entry thread	
						50 Hz	60 Hz	50 Hz	60 Hz	kg	kN	Weight kg	50 Hz		60 Hz	400 V 50 Hz						460 V 60 Hz	50 Hz									60 Hz
three-phase	601225	MVB 1510/15-FLC	50	•	150°C	1500	1500	14.7	14.7	54,5	1100	1200	2.10	2.00	3.76	4.50	MVB 1510/15-FLC	L	476	350	260	305	21	6	174	150	27	30	71	71	35	M25x1,5
	601134	MVB 2500/15-FLC	60	•	/	2500	2500	24.5	24.5	67.0	2150	2700	3.90	4.10	5.60	5.81	MVB 2500/15-FLC	L	587	350	260	305	21	6	189	162	27	30	71	71	40	M25x1,5
	601135	MVB 4500/15-FLC	80	•	/	4500	4500	44.1	44.1	106	4000	4200	6.70	5.80	4.48	4.18	MVB 4500/15-FLC	L	664	400	310	355	23.5	6	220	190	30	15	75	75	52	M25x1,5
	601136	MVB 7000/15-FLC	90	•	/	7000	7000	68.7	68.7	160	7000	7000	11.8	10.2	6.19	6.73	MVB 7000/15-FLC	L	740	508	348	348	25	8	255.5	224.5	32.5	30	79	79	52	M32x1,5

Ia/In = ratio between start-up current and maximum current.

## Versions

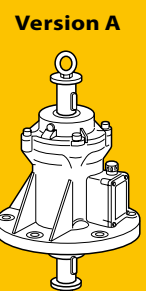

Basic model.

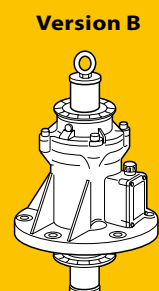

Basic model with angle disc.

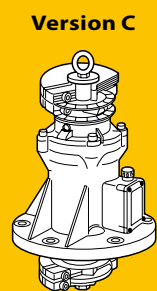

Basic model with angle disc and weights type C (clamped).

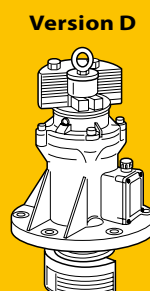

Basic model with angle disc and weights type D (lamellar).

Each C type weight group (in twos) is adjustable by phase shifting one in respect to the other. Each D type weight group (lamellar) is adjustable by removing one or more lamellar elements.

**Weight adjustment:** the weights at the two ends of the shaft can be staggered as required, with reference to the graduated discs on the shaft itself.

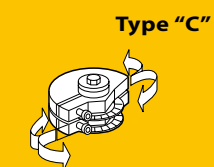

Infinitely adjustable centrifugal force

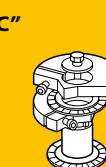

Centrifugal force adjustable from max. to min. by removing the lamellar weights.