

MVB-E / MVB-E-FLC



The MVB-E and MVB-E-FLC flanged vibrator series have been designed for use in industrial processes with screens and sieves in environments with a potentially explosive atmosphere, caused by gas and dusts, in compliance with ATEX Directive (94/9/CE).

These vibrators can be supplied in B, C, D versions (see page 86) according to the eccentric weights supplied with the vibrator and to be mounted by the user.

In particular, these vibrators can be used in areas 1 and 2 (gas) and in areas 21 and 22 (dusts) according to the layout and the following features:

Category: II 2 G, D

Level of protection: Ex e II, tD A21 IP66

Temperature class:
Gas: T3 (200°C) or T4 (135°C)
Dusts: 150°C

EC certificate: LCIE 06 ATEX

Areas of use: 1, 2, 21, 22

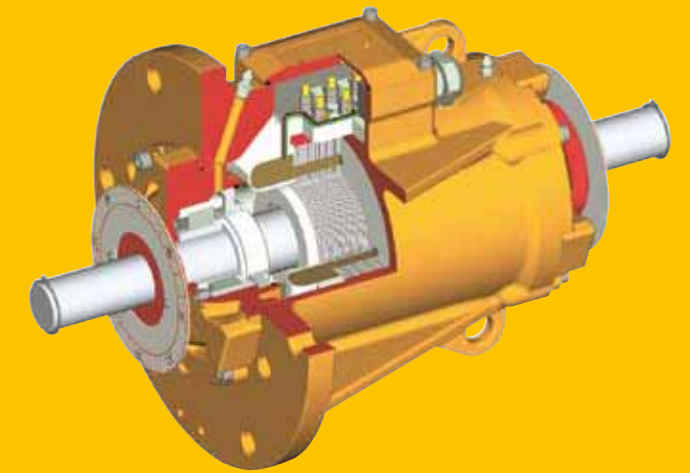

Technical features

Power supply

Three-phase voltage from 220V to 690V, 50Hz or 60Hz; suitable for use with an inverter from 20Hz to the base frequency with constant torque load profile.

Polarity

4 poles.

Conformity with European Directives

ATEX 94/9/CE; Electromagnetic Compatibility 89/336/CE

Reference Regulations

IEC/EN 60079-0, IEC/EN 60079-7, IEC/EN 61241-0, IEC/EN 61241-1, EN 60034-1, EN 50081-1, EN 50081-2, EN 50082-1, EN 50082-2.

Controls

The components that affect protection are 100% accurately controlled and recorded. The vibrators undergo 100% dynamic tests on the bench.

Functioning

Continual service (S1) at maximum declared centrifugal force and electric power.

Centrifugal force

1500 Kgf. (14.7 KN), adjustable with variation of the eccentric weights.

Mechanical protection

IP 66 according to IEC 529, EN 60529.

Shock-proof protection

IK 08 according to IEC 68, EN 50102.

Insulation class

Class F (155°C).

Tropicalization

Standard with "drop by drop" trickle system.

Environmental temperature

From -10°C to +40°C, on request it is possible to have vibrators for max. environmental temperatures 55°C. On request special greases for temperatures less than -10°C.

Vibrator heat protection

Standard PTC rated thermistor heat detectors 130°C (DIN 44081-44082) from size 80, on request for smaller sizes. Also on request thermistors with different temperatures and anti-condensation heaters.

Fixing of the vibrator

In all positions and therefore without restriction.

Lubrication

All vibrators are lubricated in the factory and do not require further lubrication if used in normal operating conditions. In heavy duty operating conditions periodical re-lubrication may be applied.

Terminal box

Large fixed electrical connections. Special shaped terminals allow to fix the power supply cable, protecting it from loosening.

Electric motor

Three-phase asynchronous type. Insulated windings using "drop by drop" trickle system with class H resin. The rotor is die cast aluminium.

Casing

In ductile cast iron to have high strength and optimal elasticity.

An external earthing screw is located on the casing as prescribed by Regulation IEC/EN 60079-0.

Bearing flange

Constructed in ductile cast iron. The geometry of the flange transmits the load to the casing uniformly.

Bearings

Custom made with particular geometry, especially designed for Italtvibras, suitable to support both high radial and axial loads.

Motor shaft

In treated steel alloy (Isothermic hardening) resistant to stress.

Eccentric weights

Lamellar for clamped centric weigh have an ample possibility of adjustment: the particular adjustment system adopted allows to obtain phase shift from 0 to 180° of the group of upper weights with respect to the group of lower weights and to have ample adjustment of the centrifugal force within the same group of weights.

Weight covers

Not envisioned in the MVB-E and MVB-E-FLC series.

Painting

Electrostatic surface treatment based on polymerised epoxy polyester powder in oven at 200°C. Tested in salt spray for 500 hours.

Other features

The MVB-E and MVB-E-FLC series are equipped with special cable-holders in compliance with ATEX Ex e II Regulations and are characterised by two plates.

Certifications



II 2 G, D – Class Ex e II T4/T3 tD A21 IP 66. IEC/EN 60079-0, IEC/EN 60079-7, IEC/EN 61241-0, IEC/EN 61241-1. Certificate n° LCIE 06 ATEX



GGTN Permit and Gost-R certificate for increased safety Ex e: GOST R 51330.0-99, GOST R 51330.8-99, GOST R IEC 61241-1-1-99.



Comply with the applicable European Union directives

MVB-E / MVB-E-FLC



MVB-E 4 poles - 1500/1800 rpm

three-phase	Description			Mechanical specifications				Electrical specifications								Type	Dimensional specifications (mm)																
	Code	Type	SIZE	Centrifugal force				Weight kg	Temp. class (G)	Temp. class (D)	Max input power W		Power rating W		Max. current A		t _E (s)	I _a /I _n	Fig.	A	øB	øC	øD	Holes		E	F	G	øI	L	M	Cable entry thread	
				50 Hz	60 Hz	50 Hz	60 Hz				kg	kN	50 Hz	60 Hz	50 Hz									60 Hz	400 V 50 Hz								460 V 60 Hz
6E1226	MVB 1510/15-E	50	1500	1500	14.7	14.7	41.5	T3 T4	150°C	1100 630	1150 700	730 480	800 530	1.90 1.33	1.82 1.27	9 5.5	4.95 7.00	MVB 1510/15-E	I	476	290	171	250	17	6	278	46	20	35	71	71	M25x1,5	

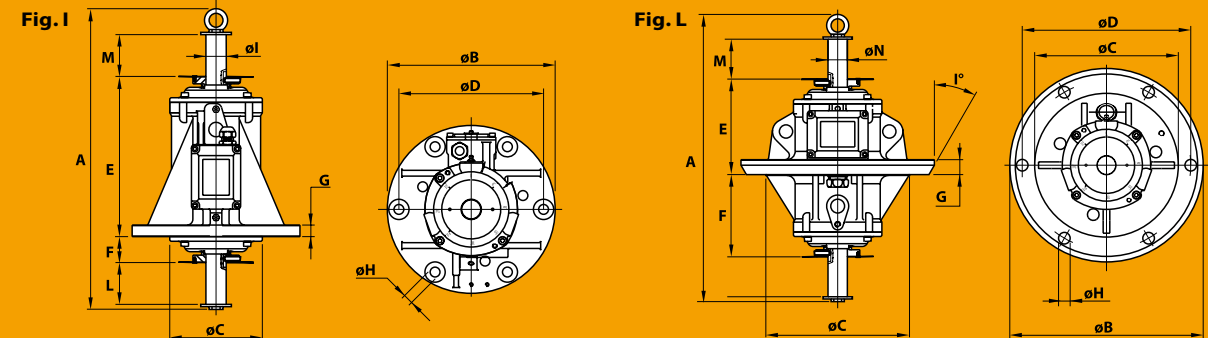

MVB-E-FLC 4 poles - 1500/1800 rpm

three-phase	Description			Mechanical specifications				Electrical specifications								Type	Dimensional specifications (mm)																	
	Code	Type	SIZE	Centrifugal force				Weight kg	Temp. class (G)	Temp. class (D)	Max input power W		Power rating W		Max. current A		t _E (s)	I _a /I _n	Fig.	A	øB	øC	øD	Holes		E	F	G	øI	L	M	øN	Cable entry thread	
				50 Hz	60 Hz	50 Hz	60 Hz				kg	kN	50 Hz	60 Hz	50 Hz									60 Hz	400 V 50 Hz									460 V 60 Hz
6E1225	MVB 1510/15-E-FLC	50	1500	1500	14.7	14.7	41.5	T3 T4	150°C	1100 630	1150 700	730 480	800 530	1.90 1.33	1.82 1.27	9 5.5	4.95 7.00	MVB 1510/15-E-FLC	I	476	350	260	305	21	6	174	150	27	30	71	71	35	M25x1,5	

t_E (s) = set time t_E from IEC/EN 60079-7. I_a/I_n = ratio between start-up current and maximum current.

Versions

Version A

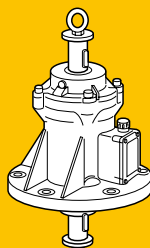

Basic model.

Version B

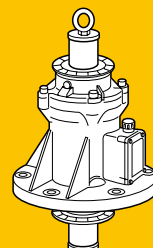

Basic model with angle disc.

Version C

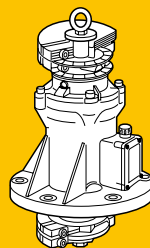

Basic model with angle disc and weights type C (clamped).

Version D

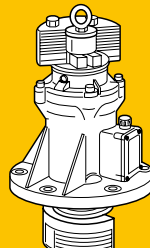

Basic model with angle disc and weights type D (lamellar).

Each C type weight group (in twos) is adjustable by phase shifting one in respect to the other. Each D type weight group (lamellar) is adjustable by removing one or more lamellar elements.

Weight adjustment: the weights at the two ends of the shaft can be staggered as required, with reference to the graduated discs on the shaft itself.

Type "C"

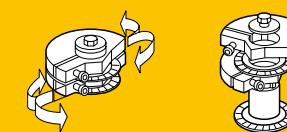

Infinitely adjustable centrifugal force

Type "D"



Centrifugal force adjustable from max. to min. by removing the lamellar weights.