

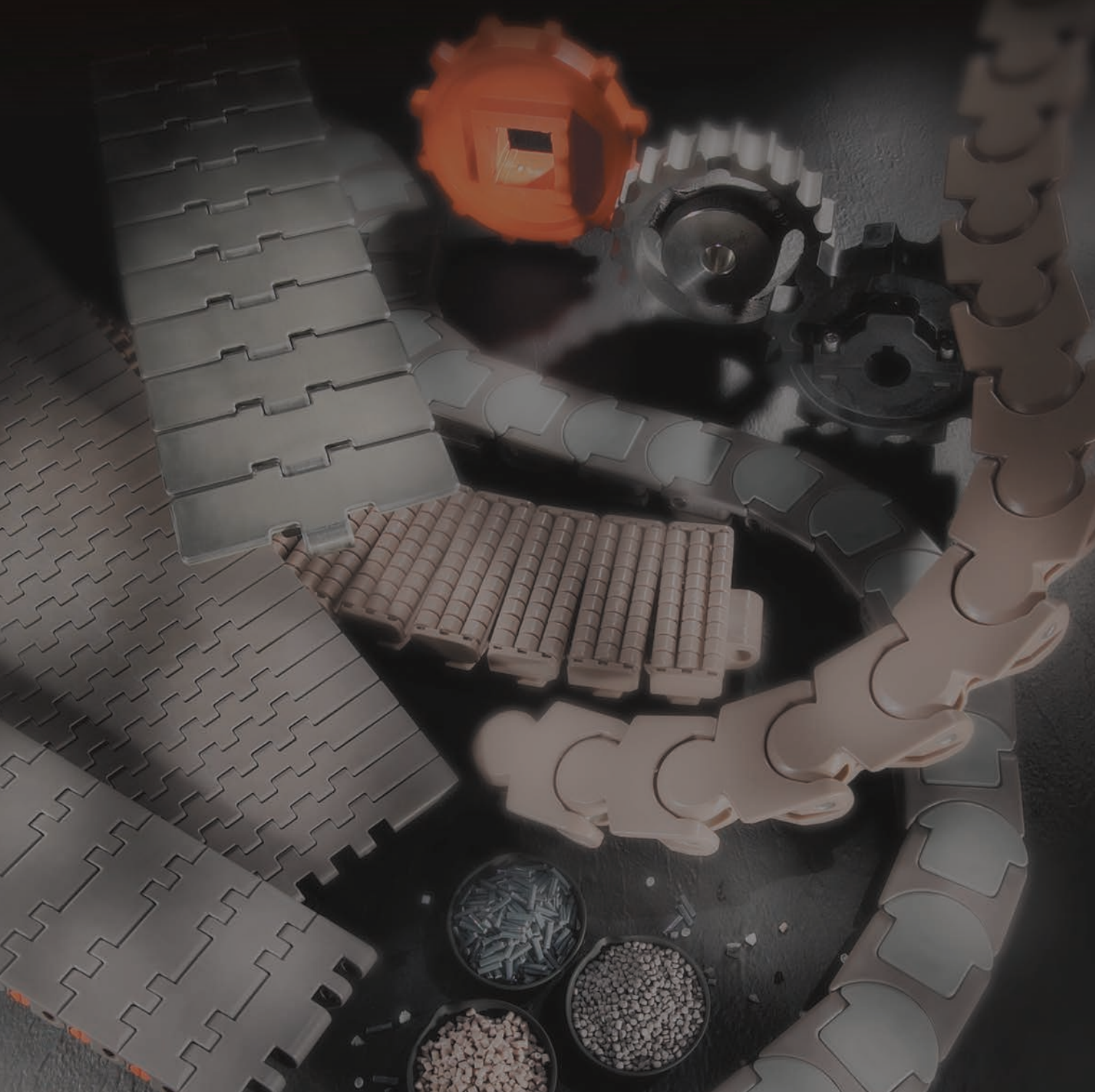

Prodotti TableTop e MatTop

Edizione 16



Soluzioni orientate al cliente. Prestazioni affidabili. Marchi di fiducia.

I nastri trasportatori e i componenti FlatTop di Rexnord® sono soluzioni all'avanguardia progettate per migliorare costantemente la produttività dei clienti in ogni applicazione. Rexnord, che vanta oltre 120 anni di esperienza, propone il più vasto assortimento al mondo di catene e componenti per nastri trasportatori, ruote dentate e accessori di alta qualità. Il nostro team di specialisti di configurazione ed esperti conoscitori del settore è a

vostra disposizione per aiutarvi a scegliere il prodotto ideale per la vostra applicazione. La nostra dedizione allo sviluppo di nuovi prodotti ci consente di offrire soluzioni di prodotti innovativi volte a soddisfare i requisiti applicativi più complessi dei nostri clienti. Ogni catena, cinghia e componente timbrati con il marchio Rexnord® sono il risultato di approfondite ricerche e hanno superato test di qualità per assicurare.

Informazioni comodamente accessibili online

Siamo consapevoli che il successo della nostra attività è determinato dalla presentazione di informazioni sui prodotti sempre aggiornate e da un'assistenza tecnica e un Servizio Clienti eccellenti. Vi invitiamo a visitare il nostro sito web, www.rexnord.com, per maggiori informazioni sui prodotti e su strumenti utili, come la ricerca dei nostri distributori, e le opzioni dell'assistenza tecnica pensate per aiutarvi a gestire la vostra attività con successo.



Le dimensioni sono soggette a modifiche.

Le dimensioni certificate dei prodotti ordinati vengono fornite su richiesta.

È vietata la riproduzione totale o parziale del contenuto del presente catalogo senza l'autorizzazione del titolare dei diritti d'autore. Rexnord è costantemente alla ricerca di metodi per migliorare i suoi prodotti e introdurre nuove tecnologie, per cui si riserva il diritto di modificare in qualsiasi momento i dati e le caratteristiche dei prodotti presentati in questo catalogo.

Per informazioni aggiornate visitate il nostro sito web: www.rexnord.com

Indice

Sommario sulle catene TableTop®	6
Introduzione alle catene a tapparella in acciaio	8
Catene tapparella in acciaio	10
Metal TableTop chains with RubberTop®	21
Introduzione alle catene a tapparella in plastica	26
Catene a tapparella in plastica	28
Catene a tapparella in plastica con superficie gommata	40
Catene lbp a tapparella in plastica	45
Catene chainbelts in plastica	50
Ruote di traino per catene a tapparella	53
Ruote di curvatura per catene a tapparella in plastica	71
Introduzione alle catene Multiflex e alle catene trasporto casse	72
Catene Multiflex	74
Ruote di traino per catene Multiflex	81
Ruote di curvatura per catene Multiflex	83
Catene trasporto casse	84
Ruote di traino per catene trasporto casse	88
Introduzione alle catene Plate Top e alle catene per elevatori e discensori	89
Catene Plate Top	91
Catene per elevatori e discensori	96
Introduzione alle curve e alle guide rettilinee	100
Curve Combi Magnetflex®	102
Curve Tab	120
Curve Bevel	124
Guide rettilinee	126
Sommario catene MatTop	128
Introduzione Alle catene MatTop	130
390-Series	132
500-Series	134
590-Series	136
1500-Series	140
8500-Series	147
5930-Series	151
1000-Series	155
1005-Series	164
1020-Series	175
1010-Series	170
7700-Series	181
2000-Series	187
2010-Series	193
6990-Series	197
3120-Series	206
Introduzione alle catene mattop per percorsi curvilinei	
505-Series	214
1200-Series	216
7956-Series	221
Numeri di codice dei nastri	223
Materiali	224
Indice Dei Prodotti	227



Le catene di trasporto Rexnord® TableTop® sono progettate per soddisfare i requisiti di una vasta gamma di applicazioni per nastri trasportatori adatte praticamente a qualsiasi settore industriale. Abbiamo progettato un vasto assortimento di catene per il trasporto in rettilineo e in curva per garantire proprietà di scorrimento impeccabili anche negli ambienti più esigenti. Le catene realizzate in metallo o in resina termoplastica sono perfette per applicazioni che richiedono

un'elevata resistenza e un'alta velocità. Le larghezze ridotte sono ideali per applicazioni multiflex e per nastri trasportatori a velocità variabile. Le catene con rulli pressori con base di sostegno bassa riducono al minimo il danneggiamento dei prodotti. Diverse serie di catene abbinano le piastre superiori a catene con base di sostegno a rullo per garantire una maggiore resistenza e precisione.

Catene di trasporto Rexnord® TableTop®

Metal TableTop Chains - Straight Running

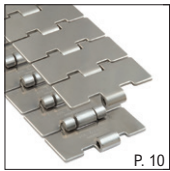

P. 10
Single Hinge

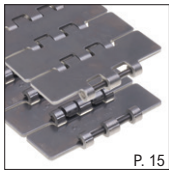

P. 15
661 Series
Double Hinge
1" Pitch

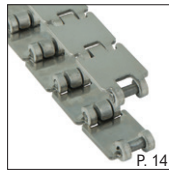

P. 14
Mini Hinge

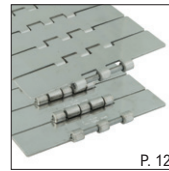

P. 12
Double Hinge

Plastic TableTop Chains - Straight running

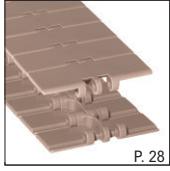

P. 28
Single Hinge

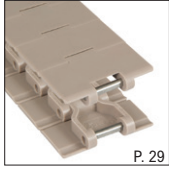

P. 29
Single Hinge
Joint Hinge

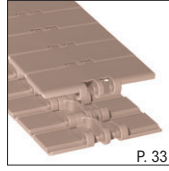

P. 33
Single Hinge With
Thick Top Plate

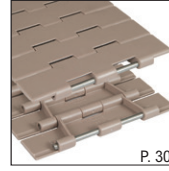

P. 30
Double Hinge

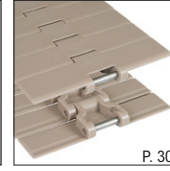

P. 30
Single Hinge
Heavy Duty

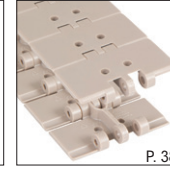

P. 38
Single Hinge
Vacuum

Metal TableTop Chains - Straight Running With RubberTop

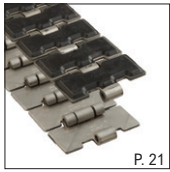

P. 21
Single Hinge

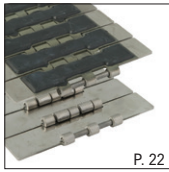

P. 22
Double Hinge

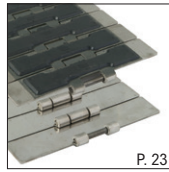

P. 23
Single Hinge
Heavy Duty

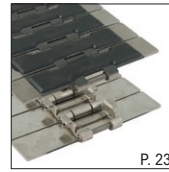

P. 23
Single Hinge
With Tab
Heavy Duty

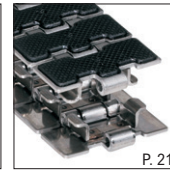

P. 21
Single Hinge
With Tab

Plastic TableTop Chains - Straight Running With RubberTop

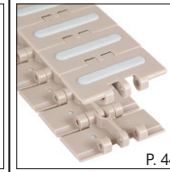

P. 44
Plastic Single
Hinge

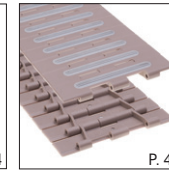

P. 41
Double Hinge

LBP Chains - Straight Running

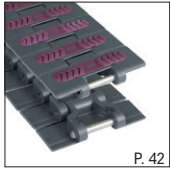

P. 42
Plastic Single
Hinge Heavy Duty

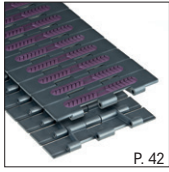

P. 42
Double Hinge
Super Grip

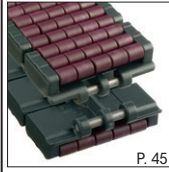

P. 45
Single Hinge

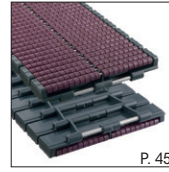

P. 45
Double Hinge

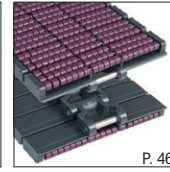

P. 46
Single Hinge
Heavy Duty

Case Conveying Chain- Without Tab

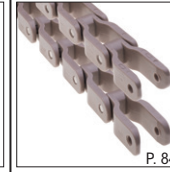

P. 84
CC600XL

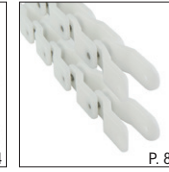

P. 85
CC1400XL

PlateTop Chains - Straight Running

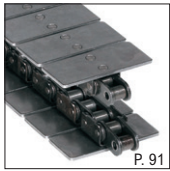

P. 91
1864

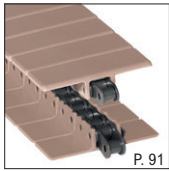

P. 91
963

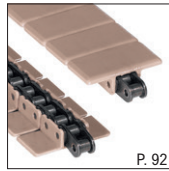

P. 92
843

Metal TableTop Chains - Side-Flexing

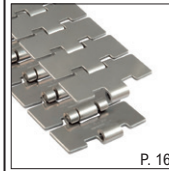

P. 16
Single Hinge
Magnetflex®

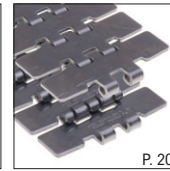

P. 20
661 Series
Double Hinge
1" Pitch

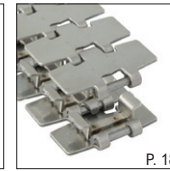

P. 18
Single Hinge
With Tab

Plastic TableTop Chains - Side-Flexing

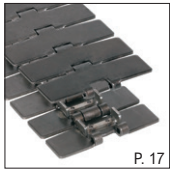

P. 17
Single Hinge
With Bevel



P. 17
Single Hinge
With Tab

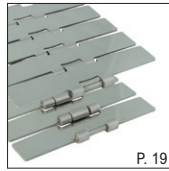

P. 19
Single Hinge
Heavy Duty
Magnetflex

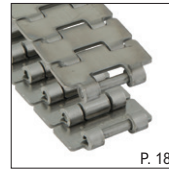

P. 18
Single Hinge
1" Pitch

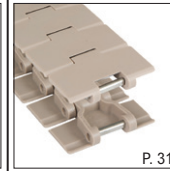

P. 31
Single Hinge
Magnetflex

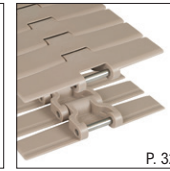

P. 32
Heavy Duty Hinge
Magnetflex

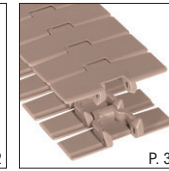

P. 32
Single Hinge
With Bevel

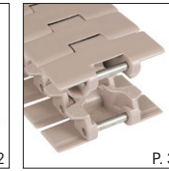

P. 37
Heavy Duty Hinge
With Tab

TableTop Side-Flexing Chains

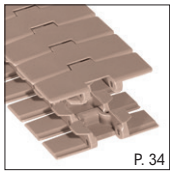

P. 34
Single Hinge
With Tab

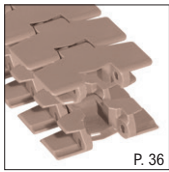

P. 36
Single Hinge
With Tab
Small Radius

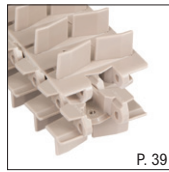

P. 39
Single Hinge
With Tab
Small Radius
With Pusher

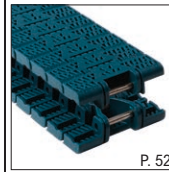

P. 52
Flush Grid
Magnetflex

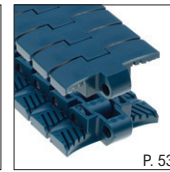

P. 53
Magnetflex

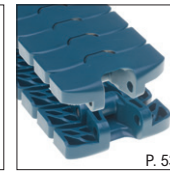

P. 53
Magnetflex
Heavy Duty

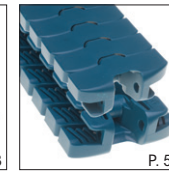

P. 54
Magnetflex
Heavy Duty
With Tab

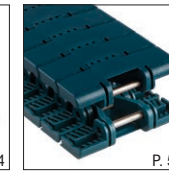

P. 50
Magnetflex 1040

Metal TableTop Chains - Side-Flexing With RubberTop®

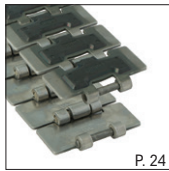

P. 24

Single Hinge

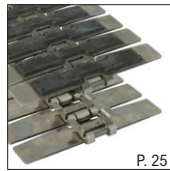

P. 25

Single Hinge
With Tab

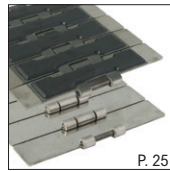

P. 25

Single Hinge
Heavy Duty

Plastic TableTop Chains - Side-Flexing With RubberTop®

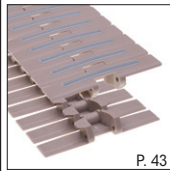

P. 43

Heavy Duty Hinge
With Tab

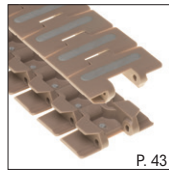

P. 43

Single Hinge
With Tab

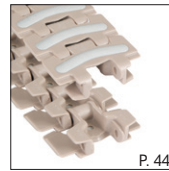

P. 44

Single Hinge
With Tab
Small Radius

LBP Chains - Side-Flexing

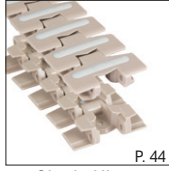

P. 44

Single Hinge
With Tab
Small Radius

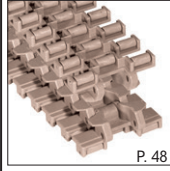

P. 48

Single Hinge
With Tab

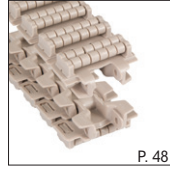

P. 48

Single Hinge
Small Radius

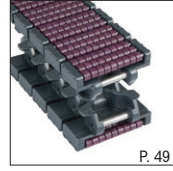

P. 49

Single Hinge
With Tab

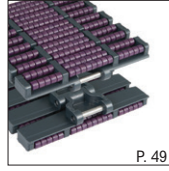

P. 49

Heavy Duty Hinge
Magnetflex®

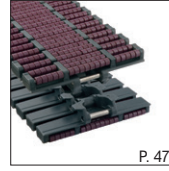

P. 47

Heavy Duty Hinge
With Tab

Multiflex Chains

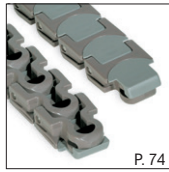

P. 74

1765 ZeroGap™

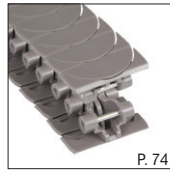

P. 74

1775 ZeroGap™

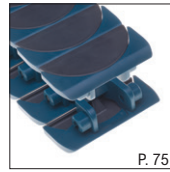

P. 75

1785 ZeroGap™



P. 75

2565 ZeroGap™



P. 76

1757TAB

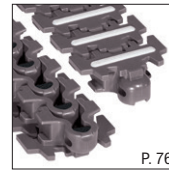

P. 76

HP1757TAB-SG

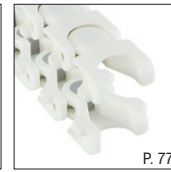

P. 77

1700TAB

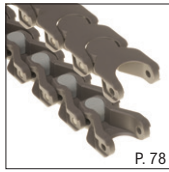

P. 78

1720

Case Conveyor Chains

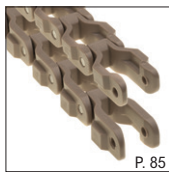

P. 85

CC600TXL



P. 85

CC1400XL

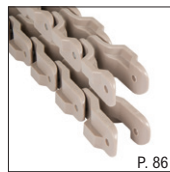

P. 86

CC1431TXL

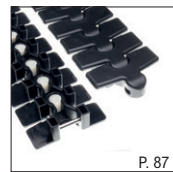

P. 87

BSM2755

PlateTop Chains - Side-Flexing

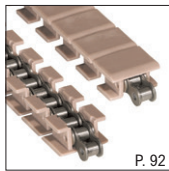

P. 92

1843TAB

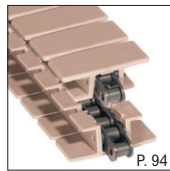

P. 94

1873TAB

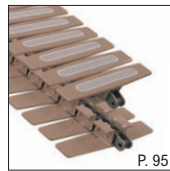

P. 95

LF1873TAB-SG

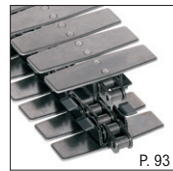

P. 93

1874TAB

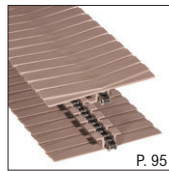

P. 95

3873TAB

PlateTop Gripper Chains - Side-Flexing

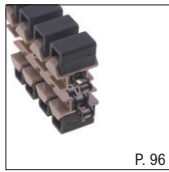

P. 96

1843 GDB

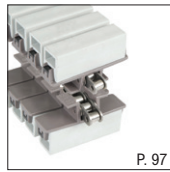

P. 97

1873 GSD



P. 97

1873 GS2J

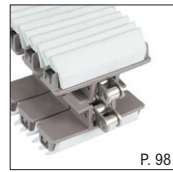

P. 98

1873 GS3J

Nel 1938 Rexnord introdusse la prima catena a tapparella in metallo con piastra superiore e cerniere integrate. Oggi le linee di prodotti Rexnord e MCC di catene a tapparelle in acciaio offrono numerosi materiali, tipi e gradi, consentendo una soluzione per molte applicazioni. Le catene a tapparelle in acciaio sono ideali per la movimentazione di bottiglie di vetro, contenitori in PET, barili, cassette e molti altri prodotti.

Caratteristiche

Finitura superficie

Quando i prodotti scorrono su una catena, la superficie inferiore agisce sulla finitura superficie della catena. I test effettuati da Rexnord hanno mostrato che durante i primi giorni successivi all'installazione, la finitura superficie iniziale diminuisce fino a raggiungere un livello che viene mantenuto per tutto il periodo di durata standard della catena. La finitura superficie è una caratteristica fondamentale, anche se non è il fattore principale che determina prestazioni buone o ottime.

Proprietà di scorrimento

Dipendono dal materiale della base e dal trattamento durante il processo di produzione. Per garantire proprietà di scorrimento elevate, Rexnord utilizza numerosi materiali per catene brevettati, appositamente studiati per le applicazioni nelle catene a piastre. Ulteriori informazioni su questi materiali vengono fornite nella pagina successiva.

Planarità

Durante l'intero processo di produzione, la planarità viene misurata nel senso della corsa (R) e nel senso della larghezza (W).

La planarità nel senso della larghezza è importante quando i prodotti scorrono affiancati da una catena all'altra. Per questo motivo, le sezioni trasversali di tutte le catene Rexnord e MCC sono convesse invece che concave, per evitare che i prodotti cadano. Grazie agli attenti controlli in fase di produzione, queste catene offrono elevatissimi valori di planarità laterale, indicati nelle tabelle della pagina relativa a ciascuna catena.

Anche la planarità quando un prodotto si sposta da una maglia all'altra della catena è importante, quindi una scarsa planarità determinerà la caduta dei prodotti, con conseguente perdita di produzione nella linea. Le catene a tapparelle in acciaio MCC e Rexnord hanno caratteristiche di notevole planarità nel senso del trasporto.

Carico di lavoro

Il carico con il quale una catena si rompe non è rilevante per stabilire se una determinata catena sia idonea o meno per la propria applicazione. Ciò che conta è il carico di lavoro massimo che una catena può sopportare prima che si verifichi una deformazione permanente. Il programma di calcolo delle catene Rexnord consente di trovare la catena giusta per le applicazioni specificate, considerando la lunghezza del trasportatore, la velocità della catena, il livello di accumulo, la lubrificazione, il tipo e il peso del prodotto.

Perni induriti

Il perno indurito riduce l'allungamento della catena in modo significativo. Perni speciali brevettati per garantire una massima resistenza all'allungamento della catena per un lungo periodo di tempo. Catena in acciaio TableTop® Serie 60-series HB con perni induriti, migliorata la resistenza all'usura. Catena in acciaio TableTop® Serie 66-series XHB con perni induriti, migliorata la resistenza all'usura e alla corrosione.

Cerniere lucidate

Le prestazioni della catena su trasferimenti laterali ad alta velocità, come ad esempio di combinatori senza pressione, migliorano con cerniere lucidate, grazie al contatto uniforme con le guide di scorrimento. Questo impedisce il pulsare della catena e migliora la movimentazione del prodotto. La maggior parte delle catene curvilinee Rexnord dispone di cerniere lucidate, i quali restano sempre a contatto con la curva. La tabella delle specifiche di ciascuna catena indica se una catena dispone di cerniere lucidate.

Serie	Ra µm
Serie MCC 10	0,5
Serie MCC 60	0,3
Serie MCC 60 HB	0,3
Serie MCC 66 XHB	0,3
Rexnord SSC OPTI-Plus Serie	0,3
Rexnord SS-Serie	0,5
Rexnord SSB-Serie	0,5
Rexnord S-Serie	non applicabile

Finitura Superficie Media Delle Catene A Piastre D'acciaio

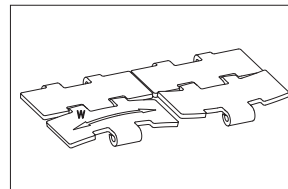

Planarità nel senso della larghezza

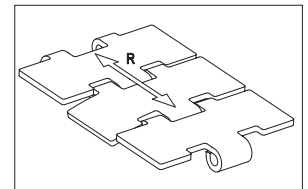

Planarità nel senso della corsa

Serie	Planarità mm
Catene MCC X-Line	0,08
Catene MCC Slideline	0,10
Catene standard MCC	0,15
Catene Rexnord SSC OPTI-Plus®	0,10
Catene standard Rexnord	0,15

Planarità nel senso della corsa



Programma

Le catene a tapparella in acciaio sono disponibili nei seguenti materiali:

Rexnord	
SSC/SSR	Lega brevettata OPTI-Plus di acciaio inossidabile al nickel-cromo ferritico, che offre carichi elevati e ottima resistenza all'usura. Queste catene dispongono di una finitura speciale e sono munite di perni in materiale AISI 431 (1.4057)
SS 805/815/881	Acciaio Austenitico inossidabile al nickel-cromo con proprietà simili al materiale 18/8, che offre una buona resistenza chimica. Queste catene sono munite di perni in acciaio Austenitico inossidabile
SS 802/812	Acciaio inossidabile al cromo ferritico per uso generico, che offre nel contempo una buona resistenza all'usura ed elevata robustezza. Queste catene dispongono di perni in materiale AISI 431(1.4057)
S/SC	Acciaio al carbonio indurito, ideale per il vetro e altre applicazioni asciutte e abrasive, che consente carichi di lavoro estremamente alti e ottima resistenza all'usura. Queste catene dispongono di perni in acciaio al carbonio indurito
SSB	Acciaio Austenitico inossidabile con una resistenza chimica altissima per ambienti corrosivi in cui sono presenti acidi o basi forti. Poiché l'SSB è praticamente non magnetico, viene utilizzato nelle applicazioni in cui il magnetismo della catena può provocare il cattivo funzionamento del sistema. Dispone di perni in acciaio Austenitico inossidabile

La descrizione della catena Rexnord inizia con il materiale, seguito dal numero 8.. per il tipo e infine dalla larghezza K.

Ad esempio, SSC 8811 TAB-K450 indica una catena larga 4½" TAB curvilinea Opti-Plus.

MCC	
10-Series	Acciaio inossidabile al cromo ferritico al 17% appositamente trattato per applicazioni generiche, offre un'elevata resistenza all'usura e robustezza, insieme a buone proprietà di scorrimento. Dispone di perni in materiale AISI 431(1.4057)
60-Series	Acciaio inossidabile al nickel-cromo ferritico speciale per applicazioni con carichi pesanti e alta velocità, che richiedono un trasferimento molto graduale di prodotti (instabili). Offre elevatissime proprietà di scorrimento ed elevati carichi di lavoro. Queste catene dispongono di perni in materiale AISI 431(1.4057)
60-Series HB	Acciaio inossidabile al nickel-cromo ferritico speciale per applicazioni con carichi pesanti e alta velocità, che richiedono un trasferimento molto graduale di prodotti (instabili). Offre elevatissime proprietà di scorrimento ed elevati carichi di lavoro. Queste catene dispongono di perni in materiale AISI 431(1.4057)
66-Series XHB	Acciaio inossidabile al nickel-cromo ferritico speciale come per la serie 60, ma per il perno viene utilizzato un materiale brevettato che offre un'elevatissima resistenza all'usura nelle applicazioni abrasive, consentendo notevoli miglioramenti per la durata
661-Series	Disegno esclusivo con passo 1" con migliore stabilità del prodotto, minore rumore e consumo di energia più basso; ideale per i prodotti meno stabili, linee ad alta velocità e negli allineatori-disallineatori.

La descrizione della catena MCC inizia con il materiale, seguito da una S che indica la corsa rettilinea, M per le catene Magnetflex, B per le catene bevel e T per le catene con alette TAB, seguito dalla larghezza e infine dall'esecuzione: S per Slideline, X per X-line, M per Max-line, e R per gomme.

Ad esempio, 60 S 31 XM indica una catena della Serie 60, corsa rettilinea, larghezza da 3¼" con X-line e Max-line.

Le catene **X-line** offrono una planarità estremamente precisa e superiori proprietà di scorrimento.

Le catene **Slideline** presentano tolleranze molto strette nella planarità e finitura superficiale.

Le catene di qualità **MAX-line** offrono una superficie di appoggio più ampia ai prodotti, data la massima dimensione della superficie della piastra.

Applicazione

Materiale Della Catena	Gestione della massa	Allineatore standard	Allineatore ad alta velocità	Abrasivo umido	Abrasivo asciutto	Prodotti chimici	Inclinazione	Movimentazione di cassette
Series 10								
SS 812/802								
Series 60								
Series 60 HB								
66-Series XHB								
SSC Opti-Plus								
SS 815/805/881								
S/SC 815								
SSB								
Superficie gommata								

Opzionale

Miglior scelta

Straight Run Single Hinge

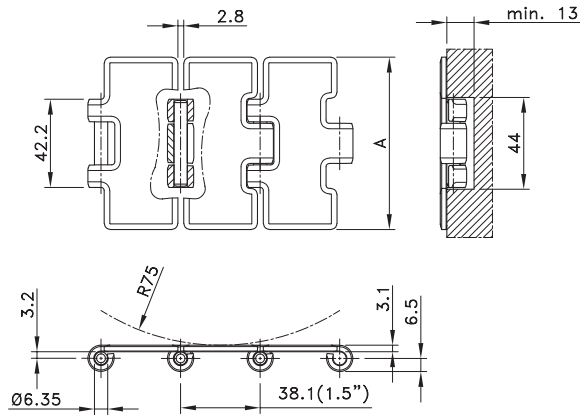
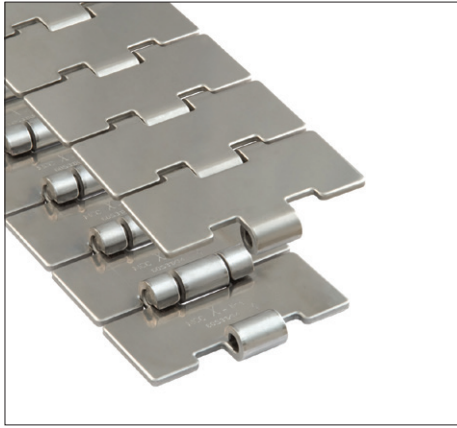

Chain Type	Code Number	Plate Width		Weight	Surface Flatness (max.)	Polished Hinge Eyes	Working Load (max.)
		A					
		mm	inch	kg/m	mm		N
10-Series							
10S31	10139369	82.5	3.25	2.55	0.10	no	4950

Standard length: 3.048 m - 10 feet (80 links).

Straight Run Single Hinge Max-Line

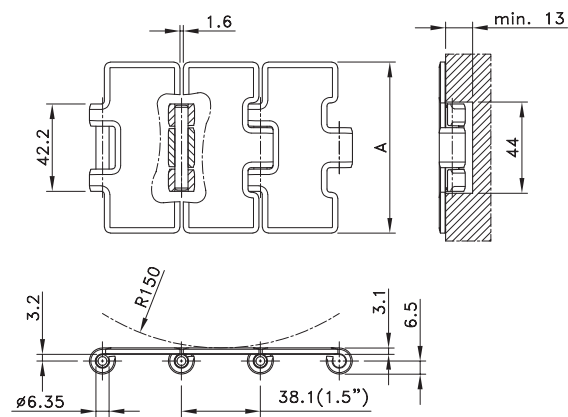
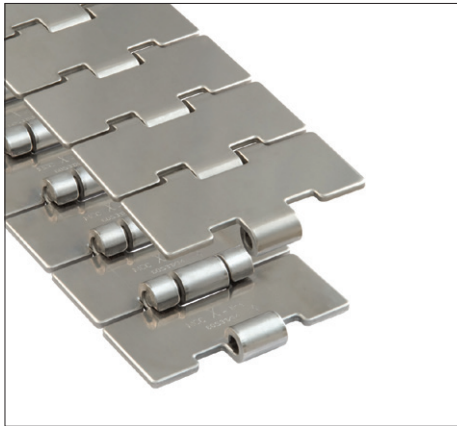

Chain Type	Code Number	Plate Width		Weight	Surface Flatness (max.)	Polished Hinge Eyes	Working Load (max.)
		A					
		mm	inch	kg/m	mm		N
10-Series							
10S31M	10139371	82.5	3.25	2.61	0.18	no	4950
10S42M	10375167	114.3	4.50	3.28	0.25	no	
10S72M	10139372	190.5	7.50	4.99	0.60	no	
60-Series							
60S22M	10375173	63.5	2.50	2.14	0.10	no	6000
60S25M	10375175	66.7	2.63	2.27	0.18	no	
60S23M	10375174	69.9	2.75	2.34	0.18	no	
60S30M	10375176	76.2	3.00	2.43	0.18	no	
60S31M	10139386	82.5	3.25	2.61	0.18	no	
60S31XM	10139394	82.5	3.25	2.61	0.08	yes	
60S84XM	10139395	84.0	3.30	2.63	0.08	yes	
60S32M	10375177	88.9	3.50	2.71	0.18	no	
60S40M	10139387	101.6	4.00	3.17	0.25	no	
60S42M	10139388	114.3	4.50	3.28	0.25	no	
60S60M	10375178	152.4	6.00	4.14	0.40	no	
60S72M	10139389	190.5	7.50	4.99	0.60	no	

Straight Run Single Hinge Max-Line (continued)

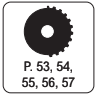
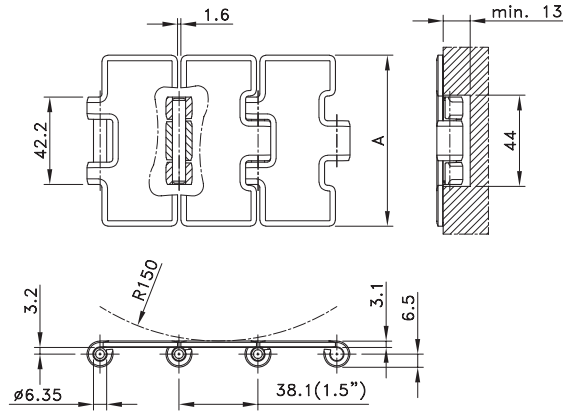

Chain Type	Code Number	Plate Width A		Weight kg/m	Surface Flatness (max.) mm	Polished Hinge Eyes	Working Load (max.) N
		mm	inch				
60-Series HB							
60S31XM HB	10374925	82.5	3.25	2.50	0.08	yes	6000
60S84XM HB	10375095	83.8	3.30	2.52	0.08	yes	
66-Series XHB							
66S31XM XHB	10139367	82.5	3.25	2.61	0.08	yes	6000
66S84XM XHB	10139368	83.8	3.30	2.63	0.08	yes	
66S72M XHB	10375156	190.5	7.50	4.99	0.60	no	
Carbon Steel							
S815-2.25IN	10139396	57.2	2.25	2.12	0.40	no	8350
S815-2.63IN	10139397	66.7	2.63	2.27	0.40	no	
S815-3.25IN	10139398	82.5	3.25	2.61	0.40	no	
S815-4IN	10139400	101.6	4.00	3.17	0.50	no	
S815-4.5IN	10139401	114.3	4.50	3.28	0.60	no	
S815-6IN	10139402	152.4	6.00	4.14	0.80	no	
S815-7.5IN	10139403	190.5	7.50	4.99	0.90	no	
Austenitic Chrome Nickel							
SS815-2.25IN	10139374	57.2	2.25	2.12	0.18	no	3500
SS815-2.625IN	10139376	66.7	2.63	2.27	0.18	no	
SS815-3.25IN	10139376	82.5	3.25	2.61	0.18	no	
SS815-3.5IN	10139378	88.9	3.50	2.71	0.18	no	
SS815-4IN	10139379	101.6	4.00	3.17	0.25	no	
SS815-4.5IN	10139380	114.3	4.50	3.28	0.25	no	
SS815-6IN	10139381	152.4	6.00	4.14	0.40	no	
SS815-7.5IN	10139382	190.5	7.50	4.99	0.60	no	
Austenitic Stainless Steel							
SSB815-3.25IN	10068058	82.5	3.25	2.61	0.18	no	2900
SSB815-4.5IN	10193960	114.3	4.50	3.28	0.25	no	
SSB815-6IN	10068059	152.4	6.00	4.14	0.40	no	
SSB815-7.5IN	10068060	190.5	7.50	4.99	0.60	no	

Standard length: 3.048 m - 10 feet (80 links).

Note: SSB 815 chains have a plate thickness of 3.0 mm instead of 3.1 mm.

Straight Run Double Hinge Max-Line

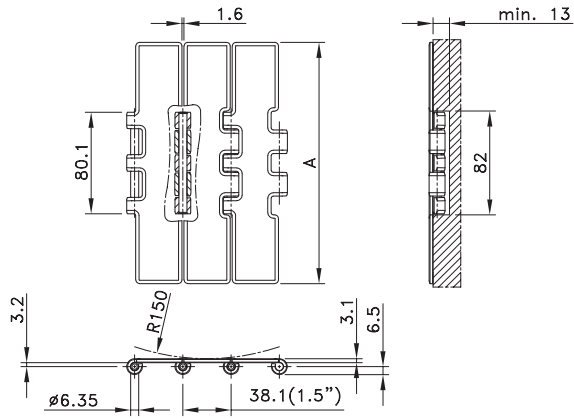
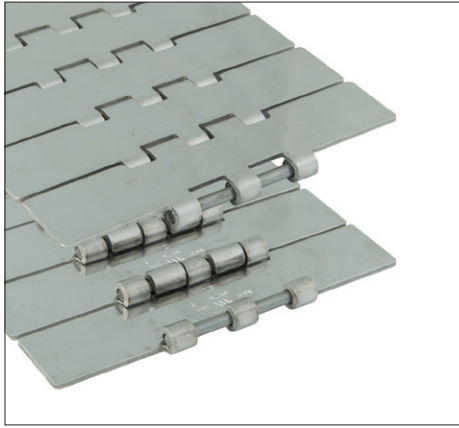

Chain Type	Code Number	Plate Width		Weight	Surface Flatness (max.)	Polished Hinge Eyes	Working Load (max.)
		mm	inch				
66-Series							
66S77M	10375158	190.5	7.50	5.64	0.60	no	8900
Opti-Plus							
SSC802-4.5IN	10375231	114.3	4.50	4.00	0.25	no	8900
SSC802-7.5IN	10068061	190.5	7.50	5.64	0.60	no	
Carbon Steel							
SC800-7.5IN	10068062	190.5	7.50	5.64	0.90	no	15000
Austenitic Chrome Nickel							
SS805-7.5IN	10068063	190.5	7.50	5.64	0.60	no	5000

Standard length: 3.048 m - 10 feet (80 links).

Straight Run Heavy Duty Max-Line

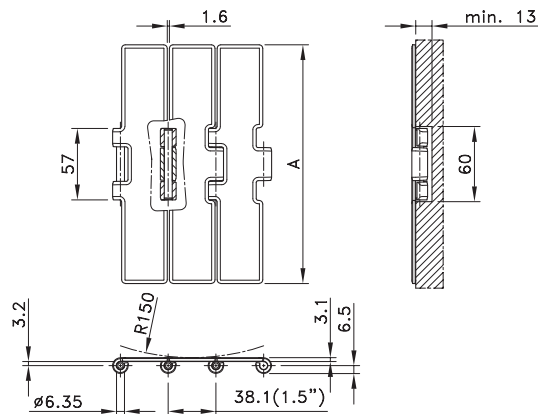
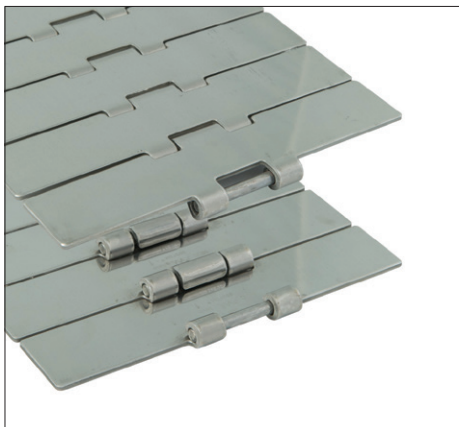

Chain Type	Code Number	Plate Width		Weight	Surface Flatness (max.)	Polished Hinge Eyes	Working Load (max.)
		mm	inch				
60-Series							
60S75M	10375097	190.5	7.50	5.10	0.60	no	7000
66-Series							
66S75M	10375157	190.5	7.50	5.10	0.60	no	7000

Standard length: 3.048 m - 10 feet (80 links).

NOTE: 60 S 75 M is recommended for medium duty applications, 66 S 75 M is recommended for heavy duty applications.

Straight Run Single Hinge Tab Max-Line

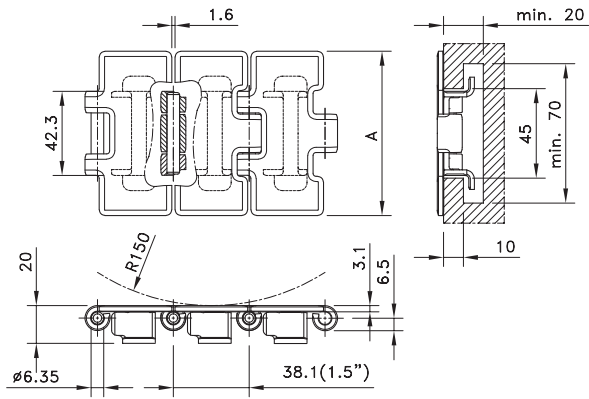

Chain Type	Code Number	Plate Width		Weight	Surface Flatness (max.)	Polished Hinge Eyes	Working Load (max.)
		A					
		mm	inch	kg/m	mm	N	
Opti-Plus							
SSC812TAB-3.25IN	10375219	82.5	3.25	3.14	0.18	no	6000
SSC812TAB-4.5IN	10375219	114.3	4.50	3.88	0.25	no	
SSC812TAB-7.5IN	10375221	190.5	7.50	5.67	0.60	no	
Carbon Steel							
S815TAB-3.25IN	10139410	82.5	3.25	3.14	0.40	no	8350
S815TAB-4.5IN	10139412	114.3	4.50	3.88	0.60	no	
S815TAB-7.5IN	10139414	190.5	7.50	5.67	0.90	no	
Austenitic Chrome Nickel							
SS815TAB-3.25IN	10139405	82.5	3.25	3.14	0.18	no	3500
SS815TAB-4.5IN	10139406	114.3	4.50	3.88	0.25	no	
SS815TAB-7.5IN	10139407	190.5	7.50	5.67	0.60	no	

Standard length: 3.048 m - 10 feet (80 links).



Straight Run Mini Hinge

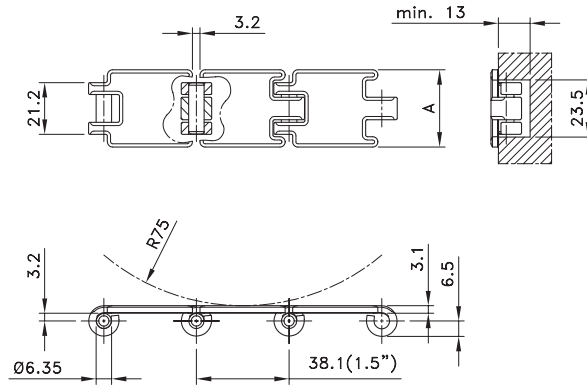
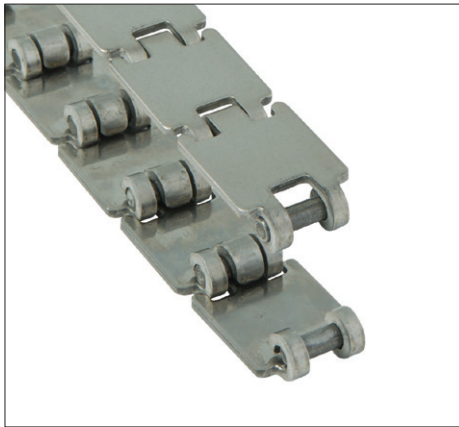

Chain Type	Code Number	Plate Width		Weight	Surface Flatness (max.)	Polished Hinge Eyes	Working Load (max.)
		mm	inch				
60-Series							
60S11*	10139384	31.8	1.25	1.07	0.18	no	2500
60S13**	10375171	44.5	1.75	1.35	0.18	no	
Carbon Steel							
SR810-1.25IN	10375235	31.8	1.25	1.07	0.40	no	3250
SR810-1.75IN	10068064	44.5	1.75	1.35	0.40	no	

* Packaging: three strands of 3.048 m - 10 feet (3 x 80 links) per box.

** Packaging: two strands of 3.048 m - 10 feet (2 x 80 links) per box.

Straight Run Single Hinge Max-Line 1"

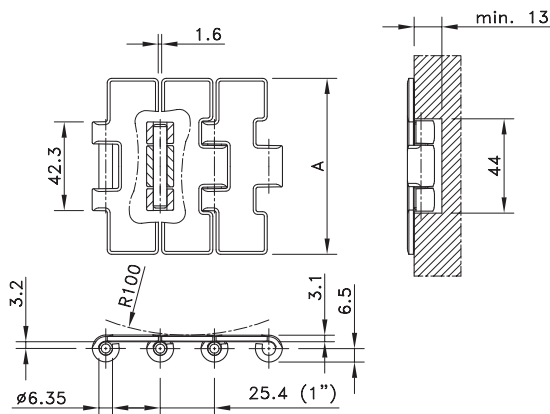
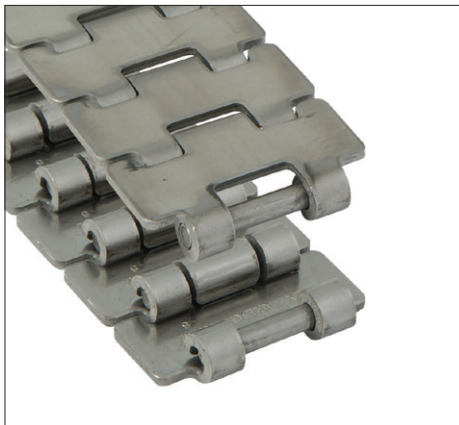

Chain Type	Code Number	Plate Width		Weight	Surface Flatness (max.)	Polished Hinge Eyes	Working Load (max.)
		mm	inch				
Opti-Plus							
SSC512-2.17IN	10178888	55.1	2.17	2.29	0.18	no	5000
SSC512-2.5IN	10375236	63.5	2.50	2.49	0.18	no	
SSC512-2.83IN	10375239	71.9	2.83	2.65	0.18	no	
SSC512-2.83IN	10375239	82.5	3.25	2.86	0.18	no	
SSC512-3.5IN	10375241	88.9	3.50	3.01	0.18	no	
SSC512-4IN	10375242	101.6	4.00	3.26	0.25	no	

Standard length: 3.048 m - 10 feet (120 links).

Straight Run Double Hinge Max-Line 1”

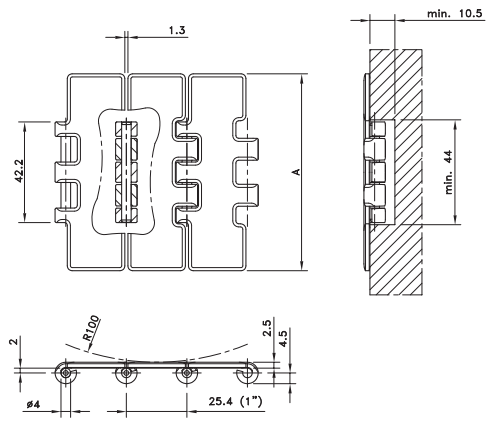
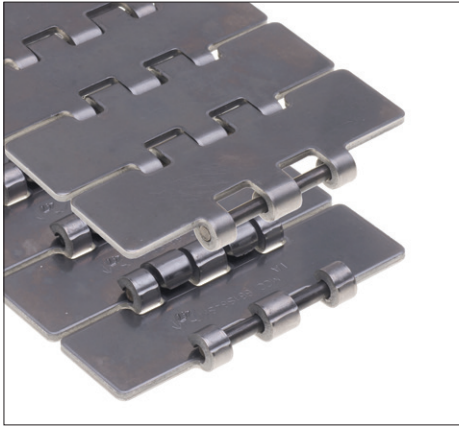

Chain Type	Code Number	Plate Width		Weight	Surface Flatness (max.)	Polished Hinge Eyes	Working Load (max.)
		A					
		mm	inch				kg/m
661-Series							
661S31SM	10186166	82.5	3.25	1.96	0.10	yes	5100
661S84SM	10375162	83.8	3.30	1.97			

Standard length: 3.048 m – 10 feet (120 links).

Magnetflex® Single Hinge Max-Line

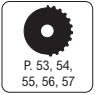
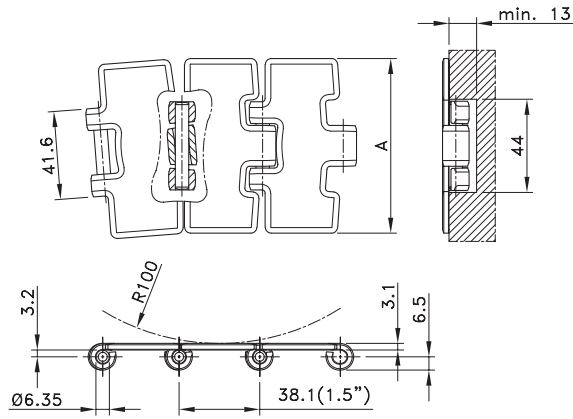
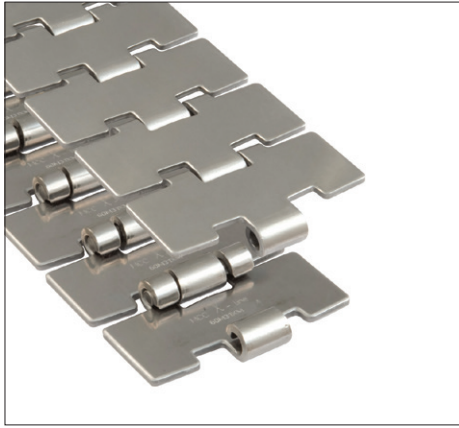

Chain Type	Code Number	Plate Width		Weight	Surface Flatness (max.)	Polished Hinge Eyes	Working Load (max.)
		A					
		mm	inch				
10-Series							
10M31M	10139432	82.5	3.25	2.50	0.18	yes	4950
10M42M	10139433	114.3	4.50	3.12	0.25	yes	
10M72M	10139434	190.5	7.50	4.59	0.60	yes	
60-Series							
60M31M	10139435	82.5	3.25	2.50	0.18	yes	6000
60M31XM	10139438	82.5	3.25	2.50	0.08	yes	
60M84XM	10139439	83.8	3.30	2.52	0.08	yes	
60M42M	10139439	114.3	4.50	3.12	0.25	yes	
60M72M	10139437	190.5	7.50	4.59	0.60	yes	
60-Series HB							
60M31XM HB	10303023	82.5	3.25	2.61	0.08	yes	6000
60M84XM HB	10201075	83.8	3.30	2.63	0.08	yes	
66-Series XHB							
66M31XM XHB	10139430	82.5	3.25	2.50	0.08	yes	6000
66M84XM XHB	10139431	83.8	3.30	2.52	0.08	yes	
66M72M XHB	10375099	190.5	7.50	4.59	0.60	yes	

Standard length: 3.048 m - 10 feet (80 links). Sideflex radius min. 500 mm.

Sideflex Single Hinge Bevel Max-Line

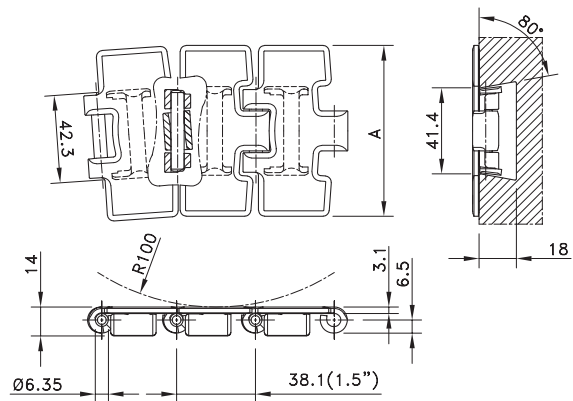
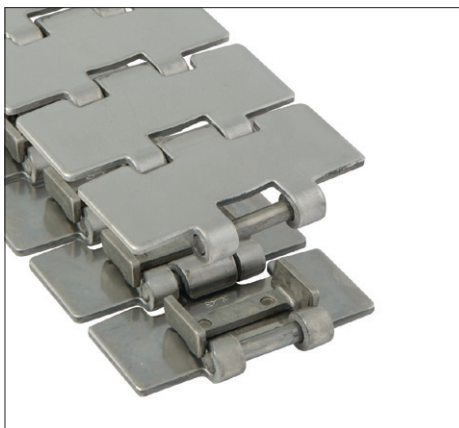

Chain Type	Code Number	Plate Width		Weight	Surface Flatness (max.)	Polished Hinge Eyes	Working Load (max.)
		A					
		mm	inch				
Opti-Plus							
SSC8811B-3.25IN	10375214	82.5	3.25	2.90	0.18	no	6000
SSC8811B-3.5IN	10375215	88.9	3.50	3.10	0.18	no	
SSC8811B-4.5IN	10375215	114.3	4.50	3.60	0.25	no	
SSC8811B-7.5IN	10068072	190.5	7.50	5.30	0.60	no	

Standard length: 3.048 m - 10 feet (80 links). Sideflex radius min. 500 mm.

Sideflex Single Hinge Bevel

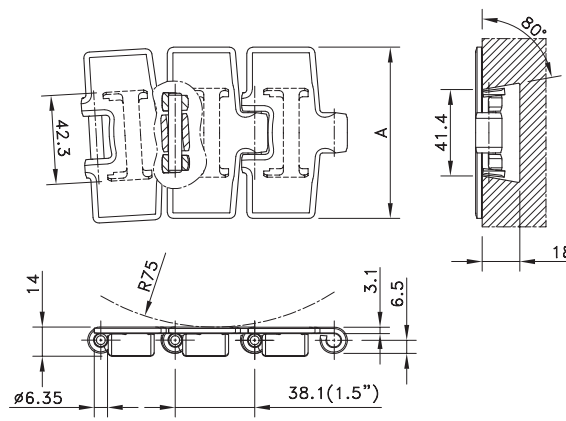

Chain Type	Code Number	Plate Width A		Weight kg/m	Surface Flatness (max.) mm	Polished Hinge Eyes	Working Load (max.) N
		mm	inch				
Austenitic Chrome Nickel							
SS881B-3.25IN	10139419	82.5	3.25	2.97	0.18	no	3500
SS881B-4.5IN	10139420	114.3	4.50	3.71	0.25	no	
SS881B-7.5IN	10139421	190.5	7.50	5.49	0.60	no	
Carbon Steel							
S881B-3.25IN	10139426	82.5	3.25	2.97	0.40	no	8350
S881B-4.5IN	10139427	114.3	4.50	3.71	0.60	no	
S881B-7.5IN	10139428	190.5	7.50	5.49	0.90	no	

Standard length: 3.048 m - 10 feet (80 links).
Sideflex radius min. 500 mm.

Sideflex Single Hinge Tab

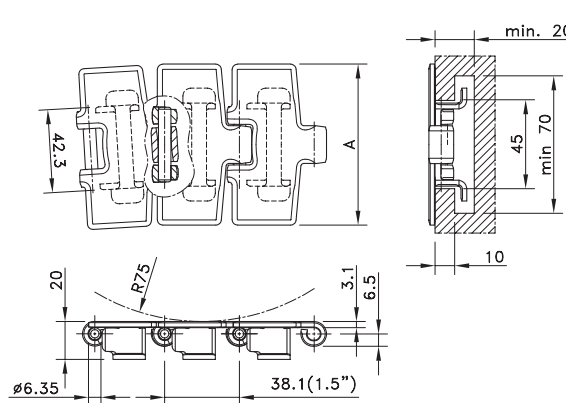

Chain Type	Code Number	Plate Width A		Weight kg/m	Surface Flatness (max.) mm	Polished Hinge Eyes	Working Load (max.) N
		mm	inch				
Austenitic Chrome Nickel							
SS881TAB-3.25IN	10139416	82.5	3.25	2.97	0.18	no	3500
SS881TAB-4.5IN	10139417	114.3	4.50	3.71	0.25	no	
SS881TAB-7.5IN	10139418	190.5	7.50	5.49	0.60	no	
Carbon Steel							
S881TAB-3.25IN	10139423	82.5	3.25	2.97	0.40	no	8350
S881TAB-4.5IN	10139424	114.3	4.50	3.71	0.60	no	
S881TAB-4.5IN	10139425	190.5	7.50	5.49	0.90	no	

Standard length: 3.048 m - 10 feet (80 links).
Sideflex radius min. 500 mm.

Sideflex Single Hinge Tab Max-Line

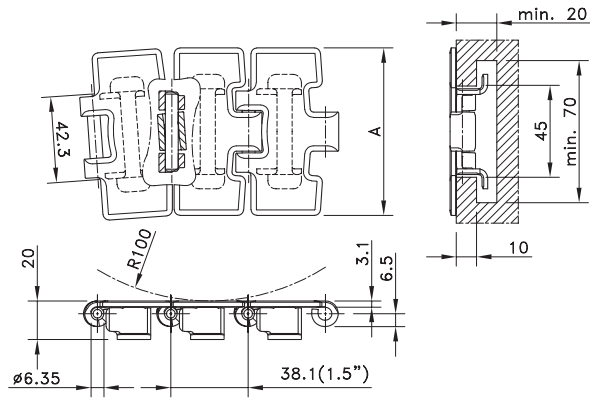
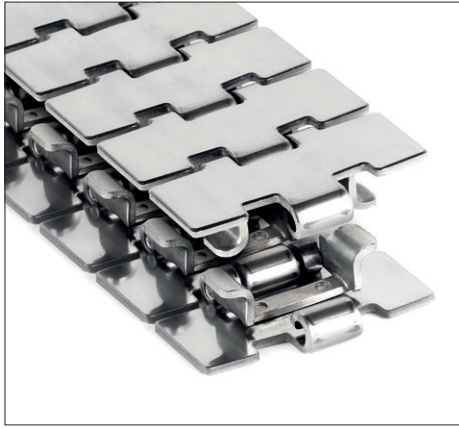

Chain Type	Code Number	Plate Width A		Weight kg/m	Surface Flatness (max.) mm	Polished Hinge Eyes	Working Load (max.) N
		mm	inch				
10-Series							
10T31M	10139441	82.5	3.25	3.10	0.18	no	4950
Opti-Plus							
SSC8811TAB-3.25IN	10068068	82.5	3.25	3.10	0.18	no	6000
SSC8811TAB-3.5IN	10375211	88.9	3.50	3.30	0.18	no	
SSC8811TAB-4.5IN	10068069	114.3	4.50	3.80	0.25	no	
SSC8811TAB-7.5IN	10068070	190.5	7.50	5.50	0.60	no	

Standard length: 3.048 m - 10 feet (80 links).
Sideflex radius min. 500 mm.

Sideflex Single Hinge Small Radius

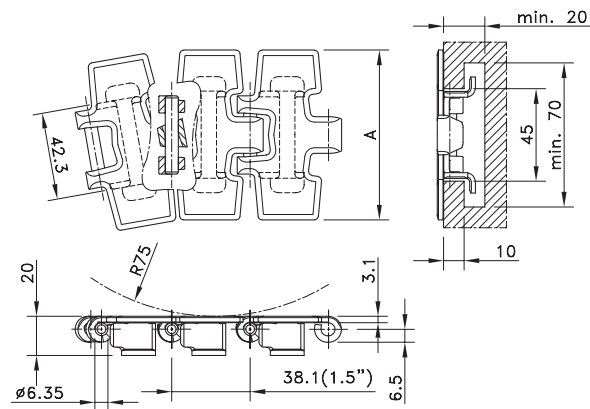

Chain Type	Code Number	Plate Width A		Weight kg/m	Surface Flatness (max.) mm	Polished Hinge Eyes	Working Load (max.) N
		mm	inch				
Opti-Plus							
SSR8811TAB BO-3.25IN	10375072	82.5	3.25	3.10	0.18	no	4500

Standard length: 3.048 m - 10 feet (80 links).
Sideflex radius min. 200 mm.

Magnetflex® Heavy Duty Max-Line

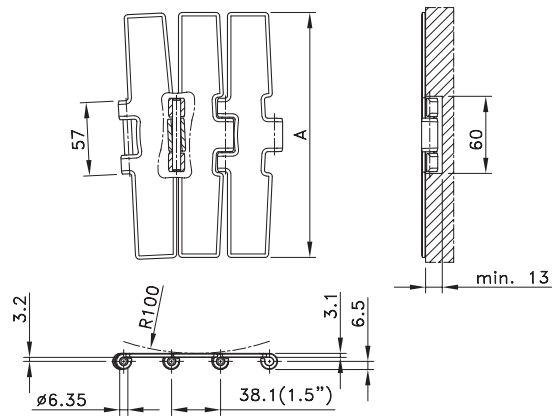

Chain Type	Code Number	Plate Width		Weight	Surface Flatness (max.)	Polished Hinge Eyes	Working Load (max.)
		A					
		mm	inch				kg/m
60-Series							
60M75M	10374937	190.5	7.50	5.03	0.60	yes	7000
66-Series							
66M75M	10375100	190.5	7.50	5.03	0.60	yes	7000

Standard length: 3.048 m - 10 feet (80 links).

Sideflex radius min. 750 mm.

NOTE: 60 M 75 M is recommended for medium duty applications, 66 M 75 M is recommended for heavy duty applications.

Magnetflex® Double Hinge Max-Line 1”

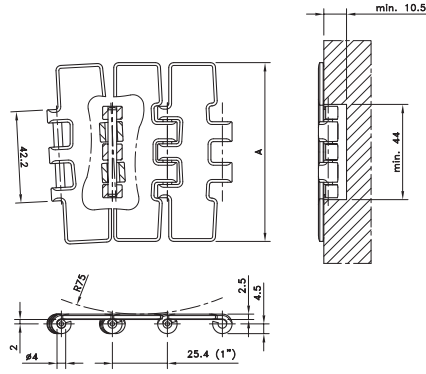

Chain Type	Code Number	Plate Width		Weight	Surface Flatness (max.)	Polished Hinge Eyes	Working Load (max.)
		A					
		mm	inch				
661-Series							
661M31SM	10375108	82.5	3.25	1.96	0.10	yes	5100
661M84SM	10375109	83.8	3.30	1.97			

Standard length: 3.048 m – 10 feet (120 links).
Sideflex radius min. 500 mm.

Straight Run Single Hinge RubberTop®

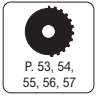
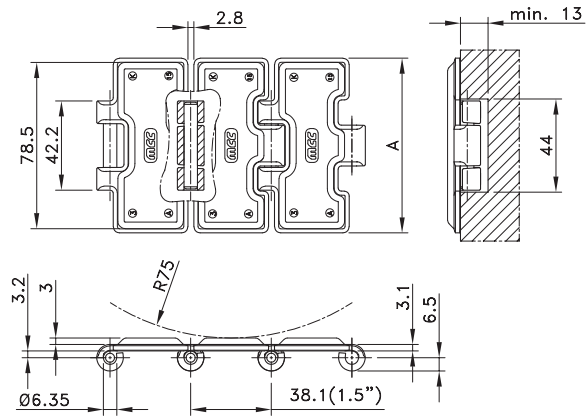
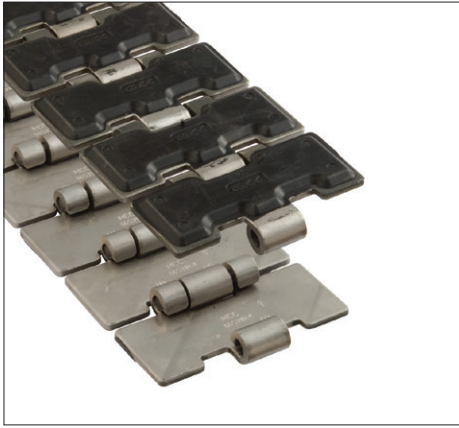

Chain Type	Code Number	Plate Width A		Weight kg/m	Polished Hinge Eyes	Working Load (max.) N
		mm	inch			
66-Series						
66S31R	10139365	82.5	3.25	2.80	no	6000

Standard length: 3.048 m - 10 feet (80 links).

Straight Run Single Hinge Tab RubberTop®

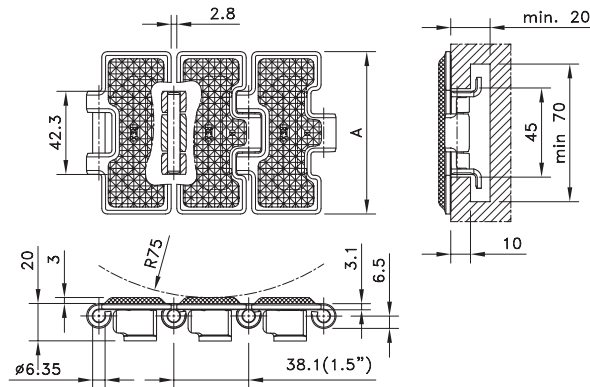

Chain Type	Code Number	Plate Width A		Weight kg/m	Polished Hinge Eyes	Working Load (max.) N
		mm	inch			
Opti-Plus						
SSR812RT TAB-3.25IN	10068067	82.5	3.25	3.40	no	6000

Standard length: 3.048 m - 10 feet (80 links).

Straight Run Double Hinge Max-Line RubberTop®

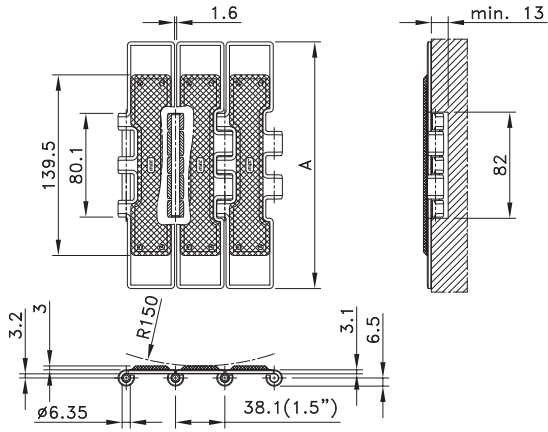
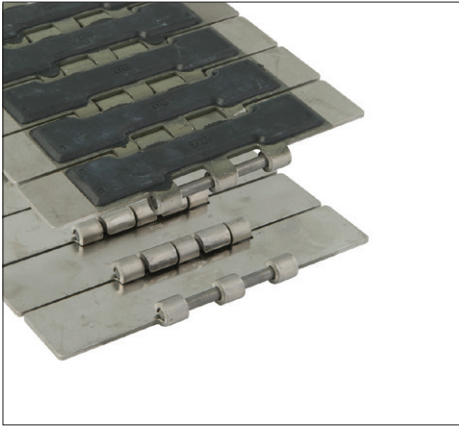

Chain Type	Code Number	Plate Width		Weight	Polished Hinge Eyes	Working Load (max.)
		A				
66-Series						
		mm	inch	kg/m		N
66S77RM	10139366	190.5	7.50	6.20	no	8900

Standard length: 3.048 m - 10 feet (80 links).



Straight Run Heavy Duty Max-Line RubberTop®

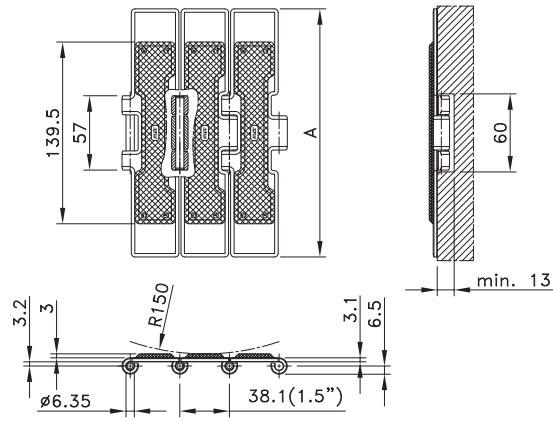
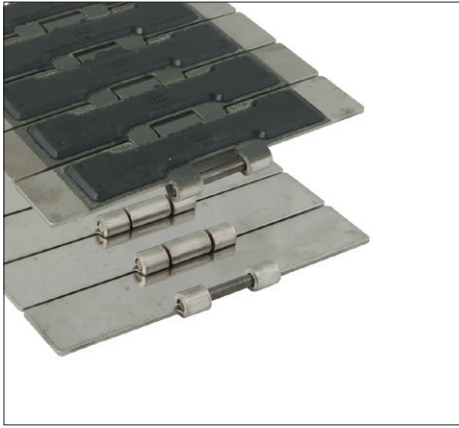

Chain Type	Code Number	Plate Width A		Weight kg/m	Polished Hinge Eyes	Working Load (max.) N
		mm	inch			
66-Series						
66S75RM	10139128	190.5	7.50	5.21	no	7000

Standard length: 3.048 m - 10 feet (80 links).

Straight Run Heavy Duty Tab Max-Line RubberTop®

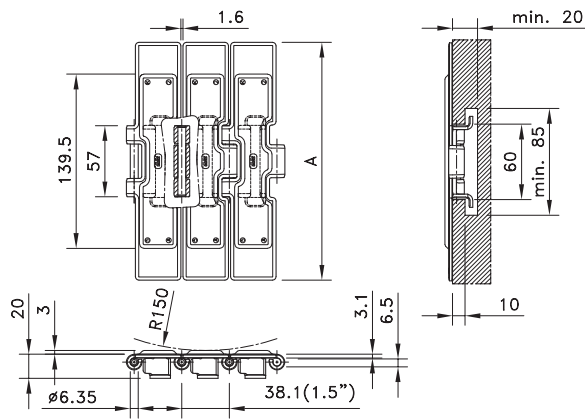
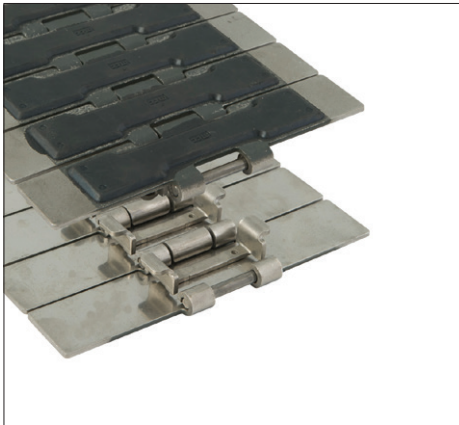

Chain Type	Code Number	Plate Width A		Weight kg/m	Polished Hinge Eyes	Working Load (max.) N
		mm	inch			
66-Series						
66ST75RM	10375069	190.5	7.50	6.21	no	7000

Standard length: 3.048 m - 10 feet (80 links).

Magnetflex® Single Hinge Max-Line RubberTop®

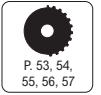
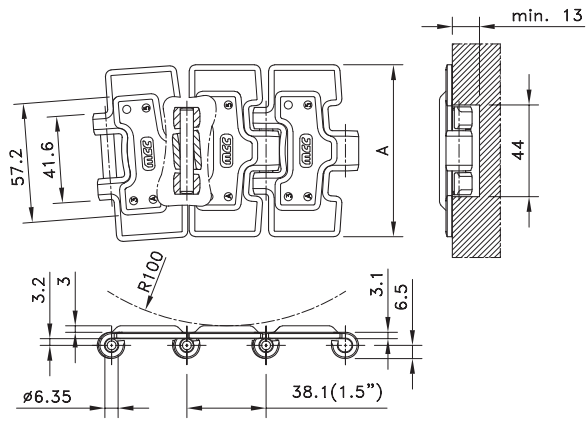
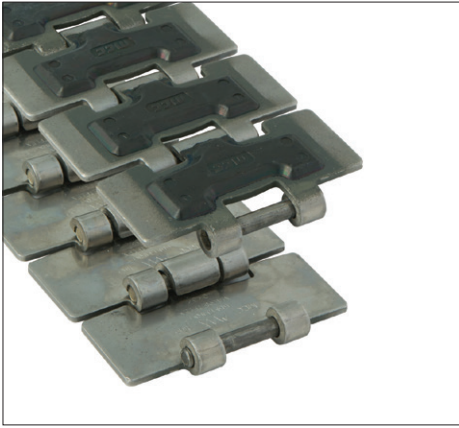

Chain Type	Code Number	Plate Width A		Weight kg/m	Polished Hinge Eyes	Working Load (max.) N
		mm	inch			
66-Series						
66M31RM	10375102	82.5	3.25	2.54	yes	6000
66M72RM	10375103	190.5	7.50	4.70	yes	

Standard length: 3.048 m - 10 feet (80 links).
Sideflex radius min. 500 mm.

Side-flexing Single Hinge Tab Max-Line RubberTop®

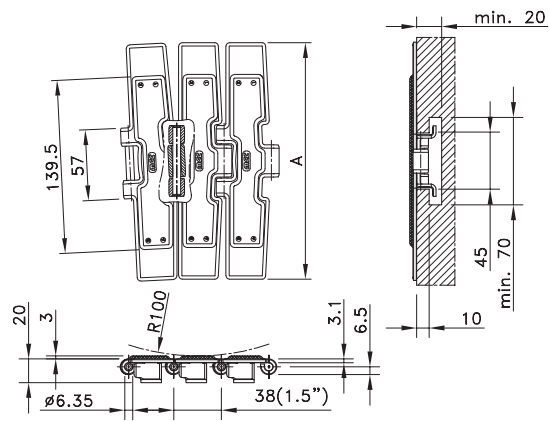

Chain Type	Code Number	Plate Width A		Weight kg/m	Polished Hinge Eyes	Working Load (max.) N
		mm	inch			
66-Series						
66T72RM	10375073	190.5	7.50	5.30	no	6000
Opti-Plus						
SSC8811RT TAB-3.25IN	10375217	82.5	3.25	3.30	no	6000

Standard length: 3.048 m - 10 feet (80 links).
Sideflex radius min. 500 mm.

Magnetflex® Heavy Duty Max-Line RubberTop®

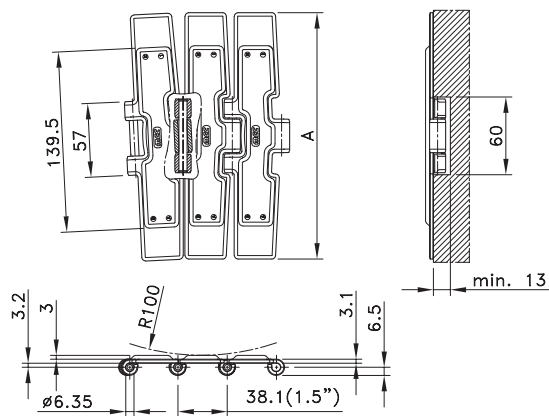
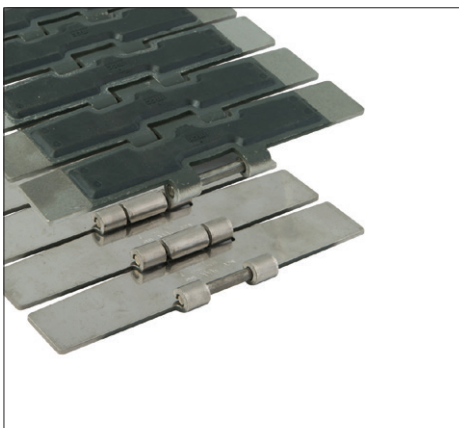

Chain Type	Code Number	Plate Width A		Weight kg/m	Polished Hinge Eyes	Working Load (max.) N
		mm	inch			
66-Series						
66M75RM	10375101	190.5	7.50	5.14	yes	7000

Standard length: 3.048 m - 10 feet (80 links).
Sideflex radius min. 750 mm.

Dai materiali standard a basso attrito a quelli speciali high-tech per applicazioni molto specifiche, la gamma di materiali plastici TableTop di Rexnord è in grado di fornire un ampio ventaglio di soluzioni per le applicazioni di trasporto per qualsiasi settore industriale.

Caratteristiche

Materiali ad elevata resistenza

Per le applicazioni a secco e con lubrificazione nel settore delle bevande, nonché per le applicazioni abrasive nel settore dei vetri, sono disponibili materiali speciali che offrono un'elevata resistenza PV o attrito estremamente basso.

Proprietà di scorrimento

To ensure superior sliding properties, Rexnord uses a number of chain materials. In many cases these materials are especially defined for conveyor applications. All different materials have friction coefficients tailored to the intended application.

Planarità

La struttura dello stampo e il controllo del processo di produzione tengono conto dei valori di planarità che soddisfano gli standard più elevati. Insieme a proprietà di scorrimento ottimali, questo evita la caduta dei prodotti trasportati.

Standardizzazione

Per la movimentazione delle casse vengono utilizzate molte catene diverse. Le catene standard (XL, LF, HP) vengono utilizzate per il trasporto generico di casse, vassoi o cassette. Le versioni ad attrito elevato (Rubber Top, SuperGrip) sono utilizzate per le inclinazioni e le discese oppure sulle cinghie di arresto. Le versioni con i rulli (LBP) sono utilizzati nei pallettizzatori di alimentazione per ridurre la pressione posteriore e il rumore. L'ampia gamma di prodotti consente la standardizzazione dei trasportatori per la movimentazione delle casse, grazie alle stesse ruote di traino, larghezza delle guide, rulli di ritorno, struttura di ritorno, guide di scorrimento e larghezza delle cerniere, anche in collaborazione con acciaio inossidabile (60 M 75 e 60 S 75). Se per la corsa rettilinea vengono utilizzati nastri modulari in plastica, le catene curvilinee chainbelts sono ideali per i trasportatori con passo da 85 mm; FGM 1050, FT 1050 e FTM 1060 con le serie 1000 e 8500, FTM 1055 e FT 1055 con le serie 1005 e 7700. Queste catene dispongono di un'area di supporto massima e di ottimi trasferimenti, anche in piccoli raggi. Per le applicazioni più difficili si consigliano le versioni FGM/FTM Magnetflex, mentre le versioni con alette FT sono destinate ad applicazioni meno impegnative.

Catene da 84 mm di larghezza

Rexnord offre una gamma completa di catene in plastica e acciaio da 84 mm di larghezza, destinate al passo standard da 85 mm dell'industria delle bevande, tra le file di trasportatori a più vie. Nelle catene di plastica, le catene rettilinee SHP84 e le catene curvilinee RHMP84 viaggiano sulle stesse ruote di traino. La distanza tra le diverse guide/vie è ridotta al minimo rispetto alle tradizionali catene da 3,25", come pure la distanza tra le maglie delle catene, per offrire una maggiore capacità di movimentazione dei prodotti e ridurre al minimo i rischi di caduta.

Perni a D

Le catene SHP, RHMP, 1060, 1055, 879, 880 e 882 sono munite di perni a D. Dopo il montaggio, la ritenzione dei perni avviene mediante adattamento geometrico, invece che mediante la tensione meccanica delle cerniere. Questo rende la catena meno sensibile all'attacco da parte di prodotti chimici; consente inoltre lo (s)montaggio da entrambi i lati delle catene, riducendo la possibilità di errore.



Programma

Le catene a tapparella in plastica sono disponibili nei seguenti materiali:

Rexnord	
LF	Acetalica a basso attrito (POM) e miscela speciale di lubrificanti. L'usura può essere ridotta fino al 15% rispetto all'acetalica standard; studiate per le applicazioni ad elevata produttività a velocità basse o elevate per il trasporto generico.
HP	Elevate prestazioni, acetalica a lubrificazione interna (POM), in grado di ridurre l'usura fino al 40% rispetto all'acetalica standard; studiate per le applicazioni o a secco o la lubrificazione ridotta e le applicazioni ad alta velocità.
	Platinum Series, acetalica a lubrificazione interna (POM). Consente di ridurre l'usura di 5 volte. I limiti PV aumentano, il che significa che una catena curvilinea stampata in PS può viaggiare 2 volte più velocemente rispetto alla stessa catena in acetalica e 1,5 volte più velocemente rispetto alle catene HP. Le bottiglie in PET che viaggiano su catene PS evidenziano l'attrito più basso disponibile, per ridurre la pressione posteriore del prodotto e ridurre al minimo le pulsazioni.
BWX	Composto di poliammide per prolungare fino a 5 volte la durata delle catene in condizioni di elevata abrasività rispetto ai materiali in acetalica; da usare nelle applicazioni per la movimentazione di vetro in cui scarti di vetro possono logorare rapidamente gli altri materiali plastici della catena; è utilizzabile anche nei casi in cui la catena viene esposta a sabbia e sporcizia.
DKA	Acetalica rinforzata con fibre aramidiche idonea per applicazione a secco o bagnate, che offre una migliore resistenza all'usura rispetto all'acetalica standard in combinazione con il basso coefficiente di attrito di un materiale lubrificato. Questo materiale è disponibile a richiesta per una gamma selezionata di prodotti TableTop.
Dry-PT	Materiale progettato specificamente per il trasporto di contenitori in PET senza ricorrere a una lubrificazione esterna Legna di polimeri a prestazioni avanzate progettata specificamente per applicazioni con funzionamento a secco. Colore: Verde lime.

Materiali anti-statici e resistenti alle sostanze chimiche possono essere forniti per un numero di catene limitato. Per maggiori dettagli, chiedere al Servizio Clienti.

Application

Materiale Della Catena	Gestione della massa	Allineatore Standard	Allineatore / PET / Alta Velocità	Abrasivo Umido	Abrasivo Asciutto
LF					
HP					
					
BWX					
DKA					
Dry-PT (only for PET)					

Opzionale	Miglior scelta
-----------	----------------

Straight Run Single Hinge

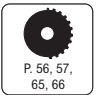
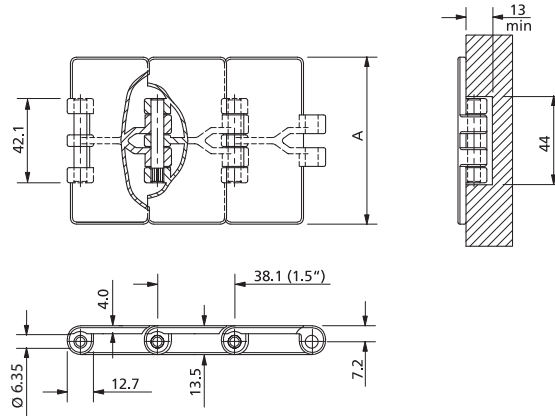
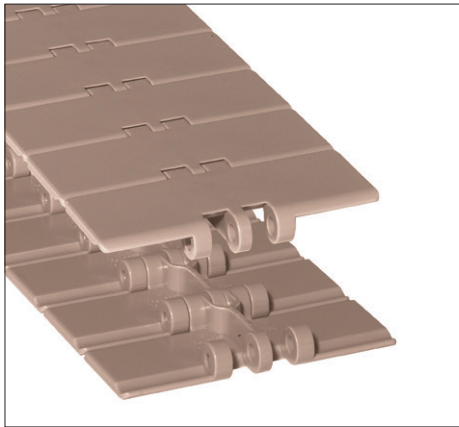

Chain Type	Code Number	Plate Width		Weight	Working Load (max.)	Backflex Radius (min)	Plate Thickness
		A					
		mm	inch	kg/m	N (21°C)	mm	mm
LF-Acetal							
LF820-2.5IN	10373807	63.5	2.50	0.73	1230	50	4.0
LF820-3.25IN	10177685	82.5	3.25	0.83	1200		
LF820-3.25IN SP*	10373866	82.5	3.25	0.63			
LF820-3.3IN	10139109	83.8	3.30	0.82	1230		
LF820-3.43IN	10373793	87.0	3.43	0.85			
LF820-3.5IN	10177476	88.9	3.50	0.87			
LF820-4IN	10177687	101.6	4.00	0.95			
LF820-4.5IN	10177688	114.3	4.50	1.03	1200		
LF820-4.5IN PA PIN	10144715	114.3	4.50	0.83	1200		
LF820-6IN	10177689	152.4	6.00	1.25	1230		
LF820-7.5IN	10177691	190.5	7.50	1.47			
HP-Acetal							
HP820-3.25IN	10144603	82.5	3.25	0.83	1230	50	4.0
HP820-3.43IN	10373794	87.0	3.43	0.85			
HP820-3.5IN	10373809	88.9	3.50	0.87			
HP820-4IN	10144606	101.6	4.00	0.95			
HP820-4.5IN	10144607	114.3	4.50	1.03			
HP820-6IN	10144608	152.4	6.00	1.25			
HP820-7.5IN	10144609	190.5	7.50	1.47			
PSX Advanced Performance Polymer Alloy							
PSX820-3.25IN	10291554	82.5	3.25	0.82	1230	50	4.0
PSX820-3.3IN	10375061	83.8	3.30	0.82			
BWX-Polyamide Composite							
BWX820-3.25IN	10373860	82.5	3.25	0.83	1230	50	4.0
BWX820-4.5IN	10373857	114.3	4.50	1.03			
BWX820-6IN	10373813	152.4	6.00	1.25			
BWX820-7.5IN	10373863	190.5	7.50	1.47			

* Pins made of black reinforced polyamide for non-magnetic or chemical applications. Ask customer service for minimum order quantity. Standard length: 3.048 m - 10 feet (80 links).

Straight Run Single Hinge Sideflex Joint Hinge

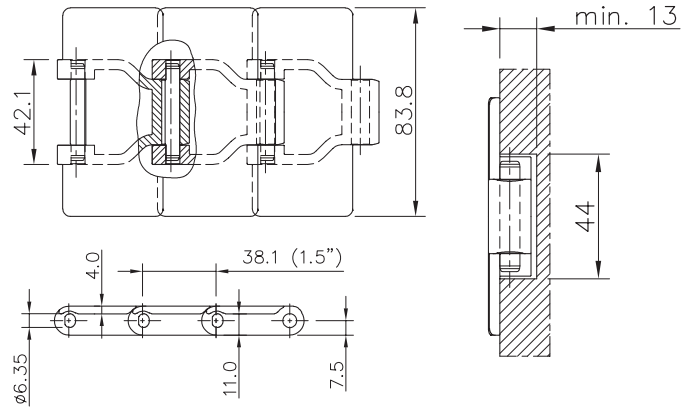
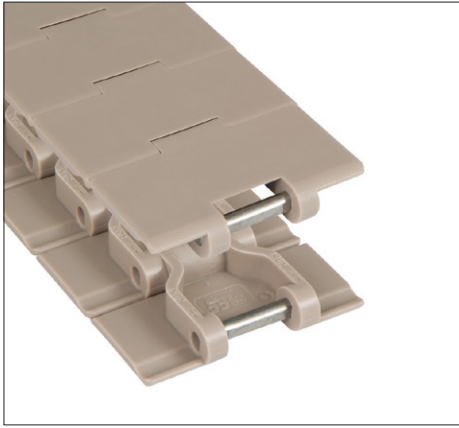

Chain Type	Code Number	Plate Width A		Weight kg/m	Working Load (max.) N (21°C)	Backflex Radius (min) mm	Plate Thickness mm
		mm	inch				
LF-Acetal							
LF_SHP-3.25IN	10375041	82.5	3.25	0.94	2100	50	4.0
LF_SHP-84MM	10139106	83.8	3.30	0.94			
PSX Advanced Performance Polymer Alloy							
PSX_SHP-3.25IN	10375060	82.5	3.25	0.94	2100	50	4.0
PSX_SHP-84MM	10375059	83.8	3.30	0.94			

Standard length: 3.048 m - 10 feet (80 links).

Straight Run Single Hinge With Thick Top Plate

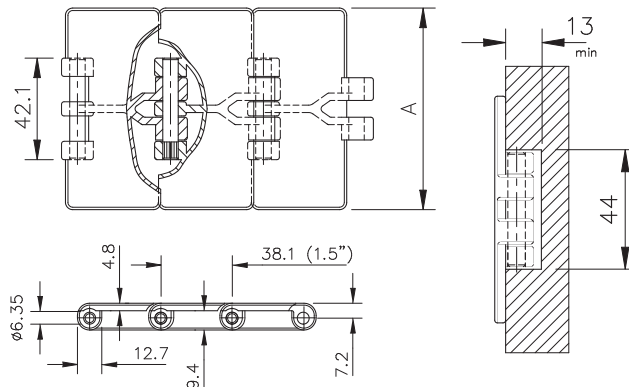
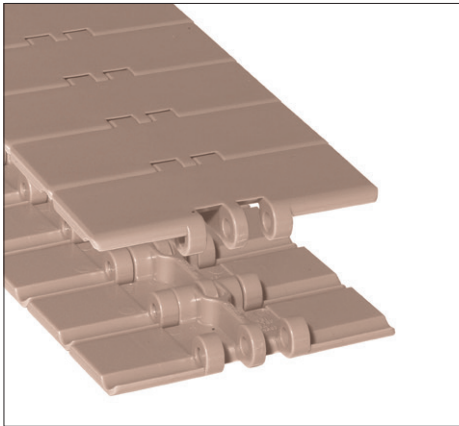

Chain Type	Code Number	Plate Width A		Weight kg/m	Working Load (max.) N (21°C)	Backflex Radius (min) mm	Plate Thickness mm
		mm	inch				
LF-Acetal							
LF831-3.25IN	10177699	82.5	3.25	0.83	1230	50	4.8
LF831-4.5IN	10177701	4.50	114.3	1.03			
LF831-7.5IN	10177703	190.5	7.50	1.47			
HP-Acetal							
HP831-3.25IN	10144614	82.5	3.25	0.83	1230	50	4.8
HP831-4.5IN	10144615	4.50	114.3	1.03			
HP831-7.5IN	10144616	190.5	7.50	1.47			
PSX Advanced Performance Polymer Alloy							
PSX831-3.25IN	10292222	82.5	3.25	0.87	1230	50	4.8
BWX-Polyamide Composite							
BWX831-3.25IN	10373758	82.5	3.25	0.87	1230	50	4.8

Standard length: 3.048 m - 10 feet (80 links).

Straight Run Double Hinge

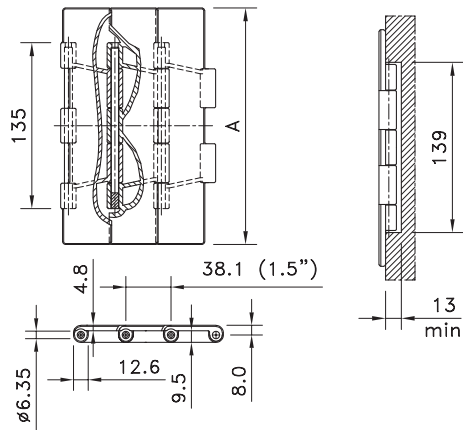
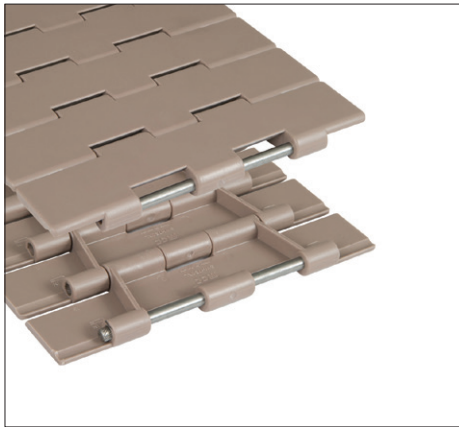

Chain Type	Code Number	Plate Width		Weight	Working Load (max.)	Backflex Radius (min)	Plate Thickness
		A					
		mm	inch	kg/m	N (21°C)	mm	mm
LF-Acetal							
LF821-7.5IN	10177696	190.5	7.50	2.50	2680	50	4.8
LF821-10IN	10177694	254.0	10.00	2.95			
LF821-12IN	10177695	304.8	12.00	3.25			
HP-Acetal							
HP821-7.5IN	10144619	190.5	7.50	2.50	2680	50	4.8
HP821-10IN	10144620	254.0	10.00	2.95			
HP821-12IN	10144621	304.8	12.00	3.25			
BWX-Polyamide Composite							
BWX821-7.5IN	10373779	190.5	7.50	2.50	2680	50	4.8

Standard length: 3.048 m - 10 feet (80 links).

Straight Run Heavy Duty

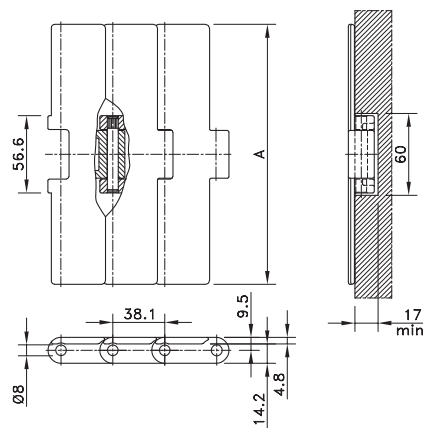

Chain Type	Code Number	Plate Width		Weight	Working Load (max.)	Backflex Radius (min)	Plate Thickness
		A					
		mm	inch	kg/m	N (21°C)	mm	mm
LF-Acetal							
LF_HDS-7.5IN	10139126	190.5	7.50	2.16	3830	50	4.8
LF_HDS-10IN	10139127	254.0	10.00	2.42			
LF_HDS-12IN	10375135	304.8	12.00	2.69			

Standard length: 3.048 m - 10 feet (80 links).

Magnetflex®

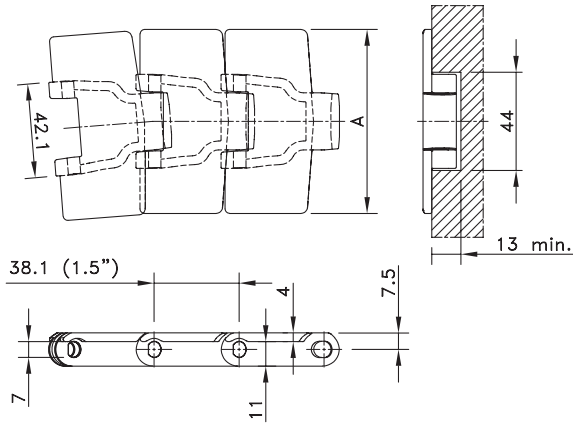
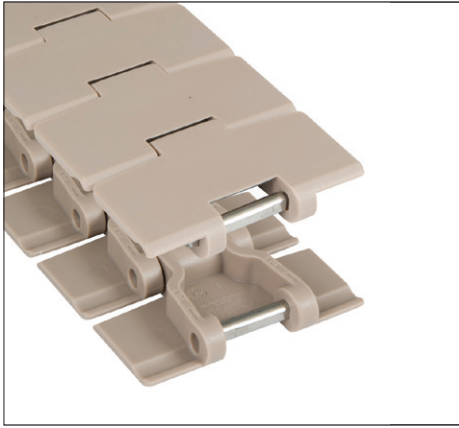

Chain Type	Code Number	Plate Width A		Weight kg/m	Sideflex Radius (min) mm	Working Load (max.) N (21°C)	Backflex Radius (min) mm	Plate Thickness mm
		mm	inch					
LF-Acetal								
LF_RHMP-3.25IN	10144173	82.5	3.25	0.82	500	2100	50	4.0
LF_RHMP-84MM	10144177	83.8	3.30	0.82				
LF_RHM-3.5IN	10374880	88.9	3.50	1.10	457			
LF_RHM-4.5IN	10144181	114.3	4.50	1.16				
HP-Acetal								
HP_RHMP-3.25IN	10144179	82.5	3.25	0.82	500	2100	50	4.0
PSX Advanced Performance Polymer Alloy								
PSX_RHMP-3.25IN	10374878	82.5	3.25	0.82	500	2100	50	4.0
PSX_RHMP-84MM	10354767	83.8	3.30	0.82				
BWX-Polyamide Composite								
BWX_RHMP-84MM	10374879	83.8	3.30	0.82	500	2100	50	4.0

Standard length: 3.048 m - 10 feet (80 links).

Magnetflex® With Thick Top Plate

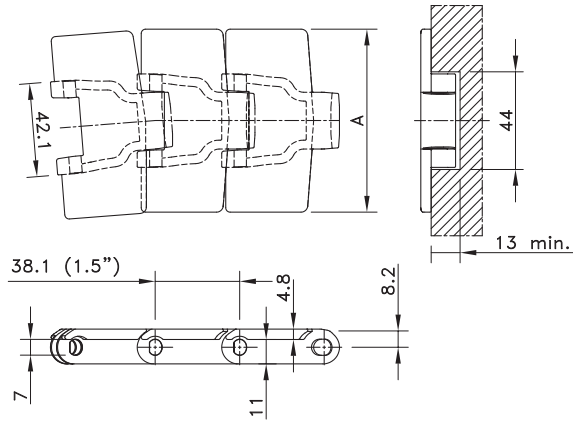
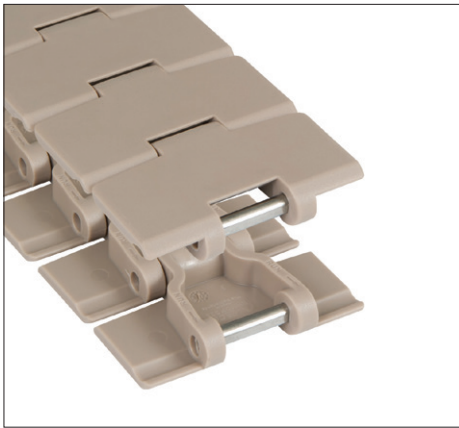

Chain Type	Code Number	Plate Width A		Weight kg/m	Sideflex Radius (min) mm	Working Load (max.) N (21°C)	Backflex Radius (min) mm	Plate Thickness mm			
		mm	inch								
LF-Acetal											
LF_RHMDP-3.25IN	10144175	82.5	3.25	1.08	500	2100	50	4.8			
LF_RHMD-4.5IN	10144182	114.3	4.50	1.26					457		
PSX Advanced Performance Polymer Alloy											
PSX_RHMDP-3.25IN	10374877	82.5	3.25	0.87	500				2100	50	4.8

Standard length: 3.048 m - 10 feet (80 links).

Magnetflex® Heavy Duty

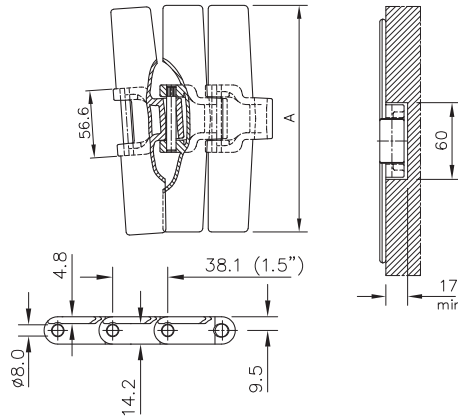

Chain Type	Code Number	Plate Width A		Weight kg/m	Working Load (max.) N (21°C)	Backflex Radius (min) mm	Sideflex Radius (min) mm	Plate Thickness mm
		mm	inch					
LF-Acetal								
LF_HDFM-7.5IN	10139118	190.5	7.50	2.16	3830	50	610	4.8
LF_HDFM-10IN	10139119	254.0	10.00	2.42				
LF_HDFM-12IN	10375019	304.8	12.00	2.69				

Standard length: 3.048 m - 10 feet (80 links).

Standard Radius Single Hinge Bevel

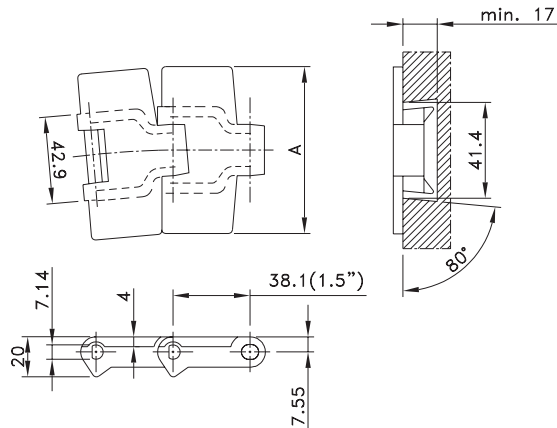
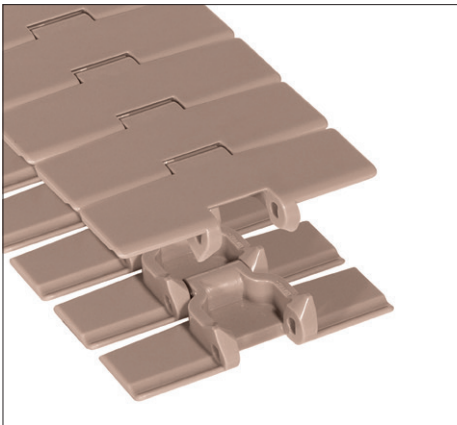

Chain Type	Code Number	Plate Width A		Weight kg/m	Sideflex Radius (min) mm	Working Load (max.) N (21°C)	Backflex Radius (min) mm	Plate Thickness mm
		mm	inch					
LF-Acetal								
LF880B-3.25IN	10177732	82.5	3.25	0.89	457	2100	40	4.0
LF880B-4.5IN	10177734	114.3	4.50	1.04				
BWX-Polyamide Composite								
BWX880B-3.25IN	10374143	82.5	3.25	0.89	457	2100	40	4.0
BWX880B-4.5IN	10374137	114.3	4.50	1.04				

Standard length: 3.048 m - 10 feet (80 links).

Standard Radius Single Hinge Bevel With Thick Top Plate

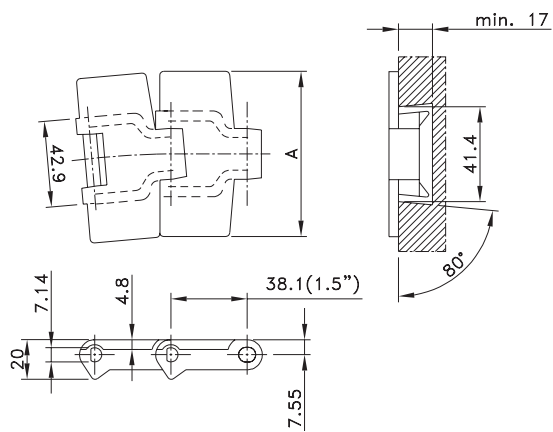
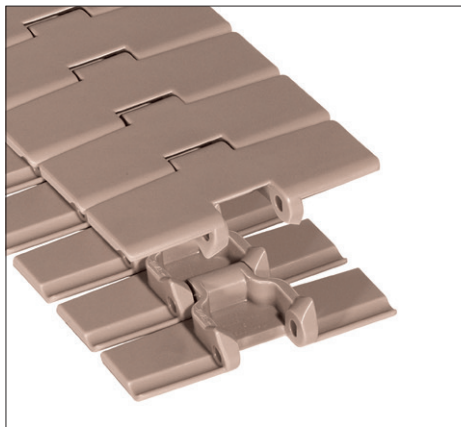

Chain Type	Code Number	Plate Width A		Weight kg/m	Sideflex Radius (min) mm	Working Load (max.) N (21°C)	Backflex Radius (min) mm	Plate Thickness mm
		mm	inch					
LF-Acetal								
LF879B-3.25IN	10177724	82.5	3.25	0.89	610	2100	40	4.8
LF879B-4.5IN	10177725	114.3	4.50	1.04				

Standard length: 3.048 m - 10 feet (80 links).

Standard Radius Single Hinge Tab

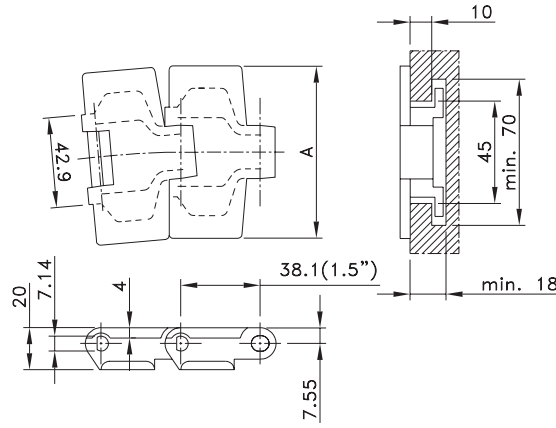
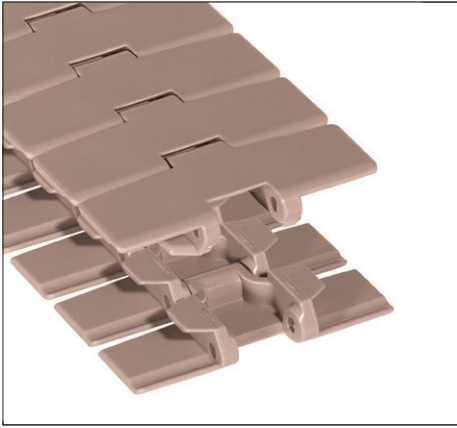

Chain Type	Code Number	Plate Width		Weight	Sideflex Radius (min)	Working Load (max.)	Backflex Radius (min)	Plate Thickness
		A						
		mm	inch	kg/m	mm	N (21°C)	mm	mm
LF-Acetal								
LF880TAB-3.25IN	10177740	82.5	3.25	0.94	457	2100	40	4.0
LF880TAB-3.3IN	10375008	83.8	3.3	1.01				
LF880TAB-3.43IN	10374085	87.0	3.43	1.01				
LF880TAB-3.5IN	10144724	88.9	3.50	1.01				
LF880TAB-3.5IN	10177743	114.3	4.50	1.08	500			
LF880TAB-3.25IN_PA	10374145	82.5	3.25	0.74	457	1050		
LF880TAB-3.25IN SS316	10374084	82.5	3.25	0.94		2100		
LF880TAB-4.5IN PA-PIN	10374084	114.3	4.50	0.91	500	1050		
LF880TAB-4.5IN SS316	10373676	114.3	4.50	1.08		2100		
HP-Acetal								
HP880TAB-3.25IN	10144626	82.5	3.25	0.94	457	2100	40	4.0
HP880TAB-3.25IN SS316	10373670	82.5	3.25	0.94				
HP880TAB-4.5IN	10144627	114.3	4.50	1.08				
HP880TAB-4.5IN SS316	10373669	114.3	4.50	1.08				
BWX-Polyamide Composite								
BWX880TAB-3.25IN	10374144	82.5	3.25	0.94	457	2100	40	4.0
BWX880TAB-4.5IN	10373676	114.3	4.50	1.08	500			
Advanced Performance Polymer Alloy								
BWX880TAB-4.5IN	10288394	82.5	3.25	0.94	457	2100	40	4.0
PSX880TAB-3.25IN SS	10374096	82.5	3.25	0.94				
PSX880TAB-4.5IN	10288395	114.3	4.50	1.08				
PSX880TAB-4.5IN SS	10374097	114.3	4.50	1.08				

* Pins made of black reinforced polyamide for non-magnetic or chemical applications. Minimum order quantity 30.48 mtr - 100 feet. Standard length: 3.048 m - 10 feet (80 links).

Standard Radius Single Hinge Tab With Thick Top Plate

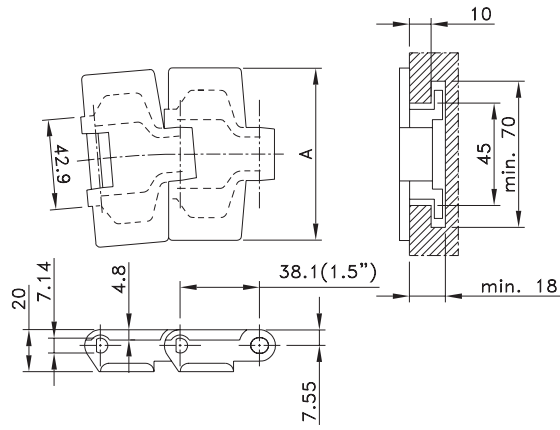
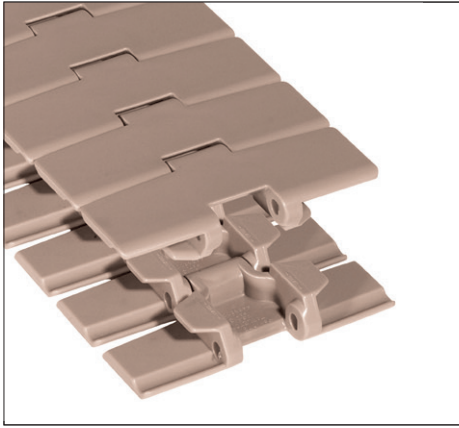

Chain Type	Code Number	Plate Width		Weight	Sideflex Radius (min)	Working Load (max.)	Backflex Radius (min)	Plate Thickness
		A						
		mm	inch	kg/m	mm	N (21°C)	mm	mm
LF-Acetal								
LF879TAB-3.25IN	10177726	82.5	3.25	0.98	457	2100	40	4.8
LF879TAB-4.5IN	10177729	114.3	4.50	1.14	610			

Standard length: 3.048 m - 10 feet (80 links).
 *Minimum order quantity 30.48 m - 100 feet.



Small Radius Single Hinge Tab

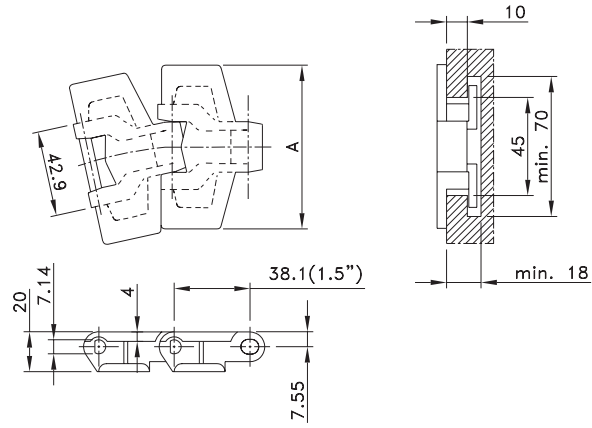
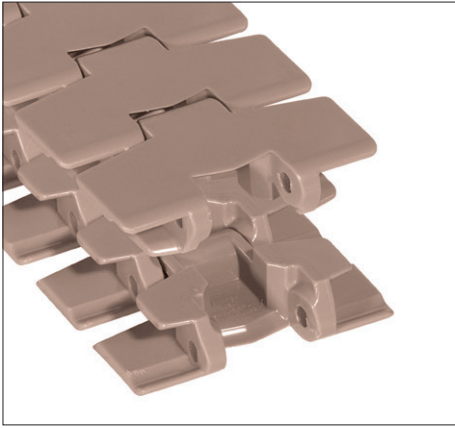

Chain Type	Code Number	Plate Width A		Weight kg/m	Sideflex Radius (min) mm	Working Load (max.) N (21°C)	Backflex Radius (min) mm	Plate Thickness mm
		mm	inch					
LF-Acetal								
LF880TAB BO-3.25IN	10144810	82.5	3.25	0.96	190	1680	40	4.0
LF880TAB BO-4.5IN	10144811	114.3	4.50	1.11				
HP-Acetal								
HP880TAB BO-3.25IN	10144923	82.5	3.25	0.96	190	1680	40	4.0
HP880TAB BO-4.5IN	10144924	114.3	4.50	1.11				

Standard length: 3.048 m - 10 feet (80 links).

Small Radius Single Hinge Tab With Thick Top Plate

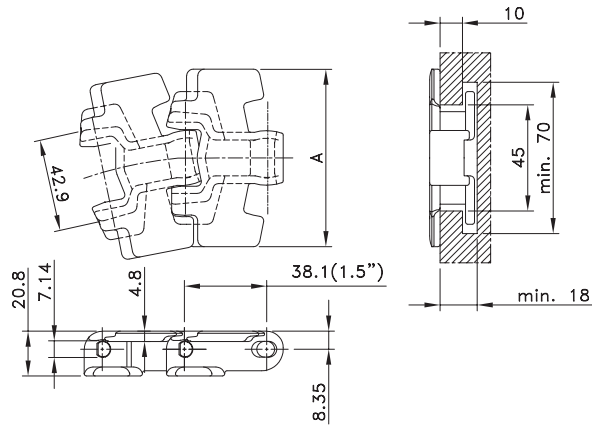

Chain Type	Code Number	Plate Width A		Weight kg/m	Sideflex Radius (min) mm	Working Load (max.) N (21°C)	Backflex Radius (min) mm	Plate Thickness mm
		mm	inch					
LF-Acetal								
LF879TAB BO-3.25IN	10177490	82.5	3.25	1.08	190	2100	40	4.8
LF879TAB BO-4.5IN	10177491	114.3	4.50	1.20				
HP-Acetal								
*HP879TAB BO-3.25IN	10373747	82.5	3.25	1.08	190	2100	40	4.8
HP879TAB BO-4.5IN	10177493	114.3	4.50	1.20				
BWX-Polyamide Composite								
*BWX879TAB BO-3.25IN	10373702	82.5	3.25	1.08	190	2100	40	4.8

Standard length: 3.048 m - 10 feet (80 links).

* Minimum order quantity 30.48 m - 100 feet.

Sideflex Tab Heavy Duty

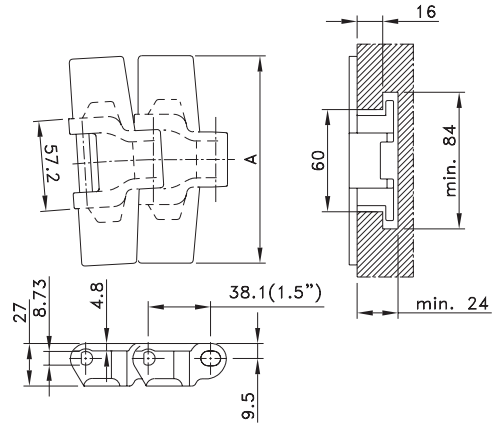
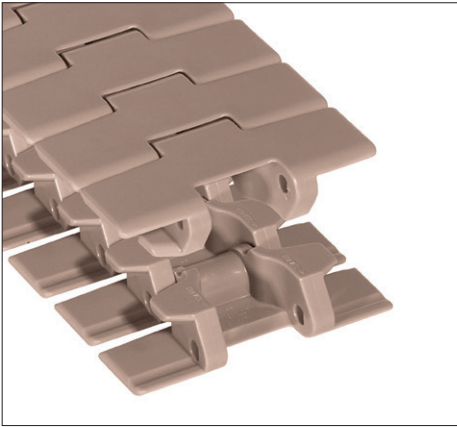

Chain Type	Code Number	Plate Width A		Weight kg/m	Sideflex Radius (min) mm	Working Load (max.) N (21°C)	Backflex Radius (min) mm	Plate Thickness mm
		mm	inch					
LF-Acetal								
LF882TAB-3.25IN*	10144749	82.5	3.25	1.86	610	3830	40	4.8
LF882TAB-4.5IN	10177754	114.3	4.50	1.98				
LF882TAB-7.5IN	10177755	190.5	7.50	2.43				
LF882TAB-10IN	10177755	254.0	10.00	2.87				
LF882TAB-12IN	10177757	304.8	12.00	3.41				

Standard length: 3.048 m – 10 feet (80 links).
 * Minimum order quantity 30.48 m – 100 feet.

Sideflex Tab Vacuum

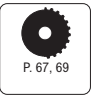
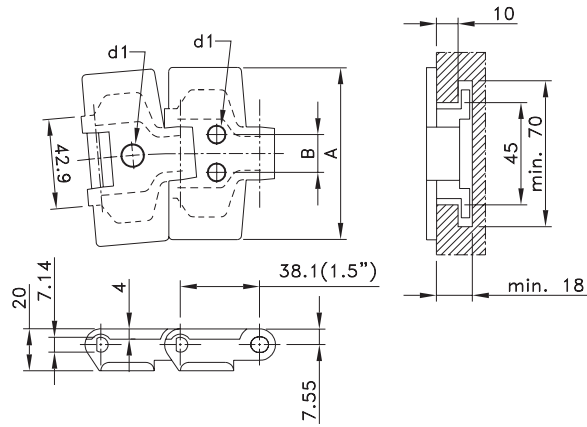
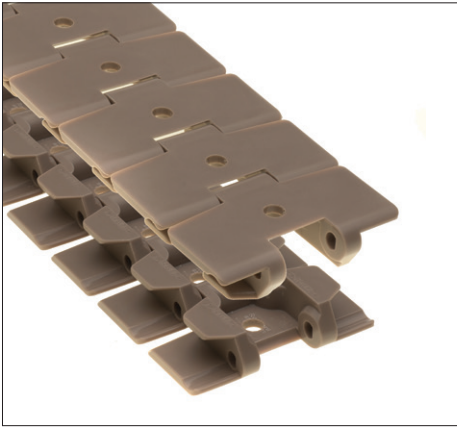

Chain Type	Code Number	Plate Width A		Weight	Distance Between Holes B	Hole Diameter d1	Sideflex radius (min.)	Working Load (max.)	Backflex Radius (min)	Plate Thickness
		mm	inch							
LF-Acetal										
LF880TAB V-3.25IN E1D6.5MM*	10461339	82.5	3.25	0.94	-	6.5	457	2100	40	4.0
LF880TAB V-3.25IN E1D8MM*	10374069	82.5	3.25	0.94	-	8.0				
LF880TAB V-3.25IN E1D10MM*	10374114	82.5	3.25	0.94	-	10.0				
LF880TAB V-3.25IN E2D6MM**	10374129	82.5	3.25	0.94	24	6.0				
LF880TAB V-3.25IN E2D8MM**	10374090	82.5	3.25	0.94	20	8.0				
LF880TAB V-4.5IN E2D6MM (I=24)**	10374130	114.3	4.50	1.08	24	6.0	500			

* 1 hole. Minimum order quantity 30.48 m – 100 feet.
Standard length: 3.048 m - 10 feet (80 links).
** 2 holes.

Straight Run Vacuum

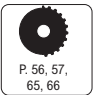
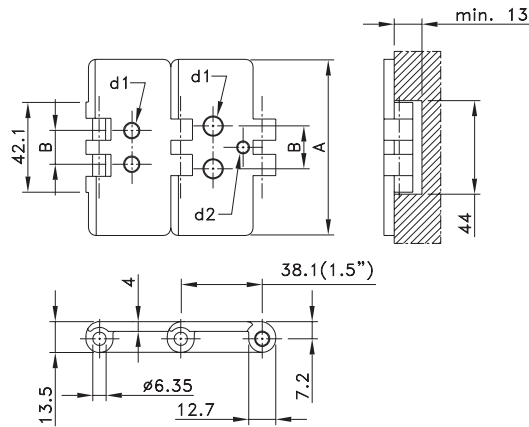
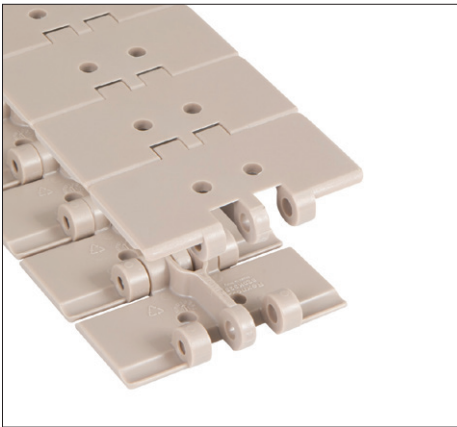

Chain Type	Code Number	Plate Width A		Weight	Distance Between Holes B	Hole Diameter d1	Working Load (max.)	Backflex Radius (min)	Plate Thickness	
		mm	inch							kg/m
LF-Acetal										
LF820 V-3.25IN E2D6.5MM**	10373838	82.5	3.25	0.83	19	6.5	1230	40	4.0	
LF820 V-3.5IN E2D4MM**	10373803	88.9	3.50	0.87	45	4.0				
LF820 V-4.5IN E2D8MM**	10373865	114.3	4.50	1.03	30	8.0				
LF820 V-4.5IN E2D8MM SP**	10670608	114.3	4.50	1.03	50	8.0				
LF820 V-3.25IN E3D7.9-4.4MM***	10373826	82.5	3.25	0.83	20	7.9				

** 2 holes.
*** 3 holes. Hole diameter 3rd hole (d2) is 4.4 mm.
Standard length: 3.048 m - 10 feet (80 links).
Minimum order quantity 30.48 m – 100 feet.

Sideflex Tab With Flights

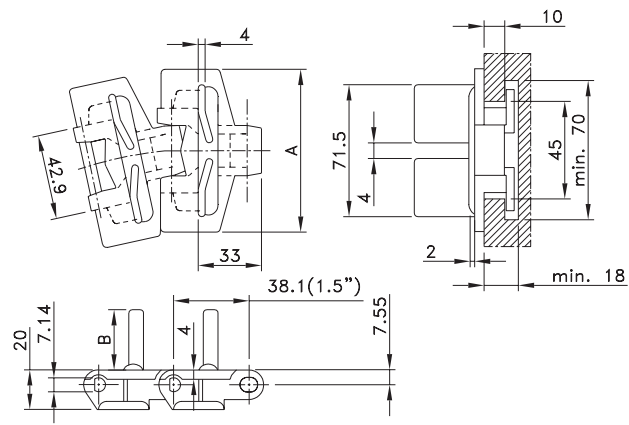
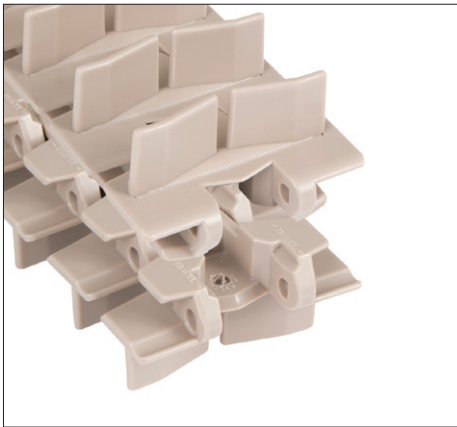

Chain Type	Code Number	Plate Width		Weight	Sideflex Radius (min)	Working Load (max.)	Backflex Radius (min)	Plate Thickness
		A						
		mm	inch	kg/m	mm	N (21°C)	mm	mm
LF-Acetal								
LF880TAB BO-3.25IN F25MM*	10373674	82.5	3.25	0.96	190	1680	40	4.0
LF880TAB BO-3.25IN F39 T1P**	10374026	82.5	3.25	0.96				

* Height of flight (B) 25 mm.

** Height of flight (B) 39 mm.

Standard length: 3.048 m - 10 feet (80 links).

As a standard flights on every second link; other patterns are possible.

Minimum order quantity 30.48 m – 100 feet.

Straight Run Single Hinge

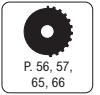
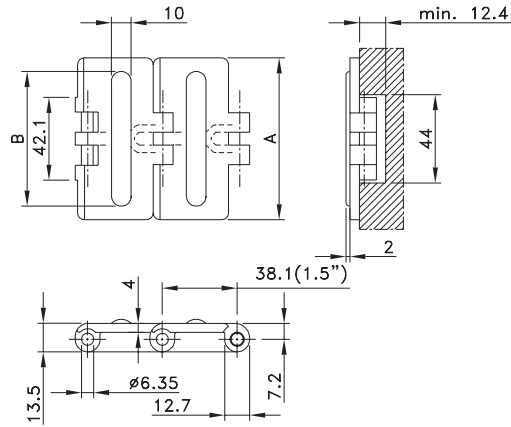
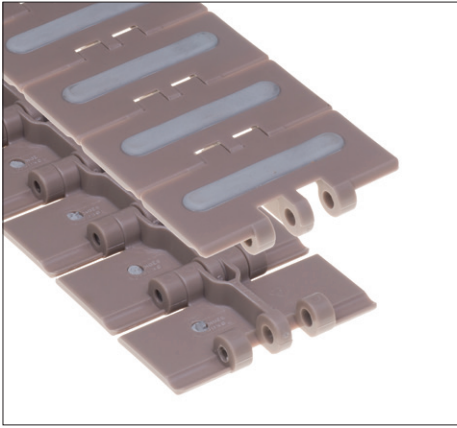

Chain Type	Code Number	Plate Width		Weight	Working Load (max.)	Backflex Radius (min)	Plate Thickness
		A					
		mm	inch	kg/m	N (21°C)	mm	mm
LF-Acetal							
LF820 RT-3.25IN D60	10373800	82.5	3.25	0.83	1230	40	4.0
LF820RT-4IN D60	10373828	101.6	4.00	0.95			
LF820 RT-4.5IN D60	10373868	114.3	4.50	1.03			
LF820 RT-6IN D60	10373829	152.4	6.00	1.25			

Standard length: 3.048 m - 10 feet (80 links).

The width (B) of the rubber varies per chain type:

65.0, 84, 96 and 135.0 for respectively HFP 820-K325, HFP 820-K400, HFP 820-K450 and HFP 820-K600.

Minimum order quantity 30.48 m – 100 feet.

Straight Run Double Hinge Rubber Pushers

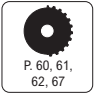
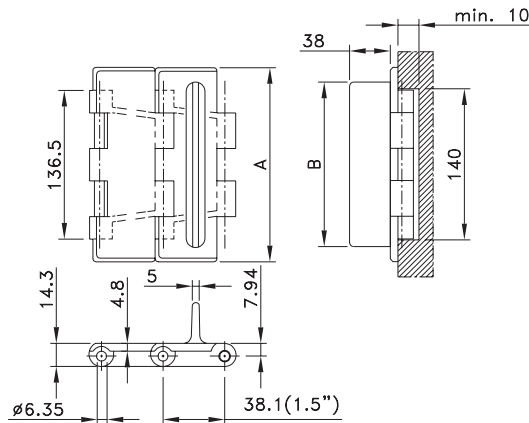
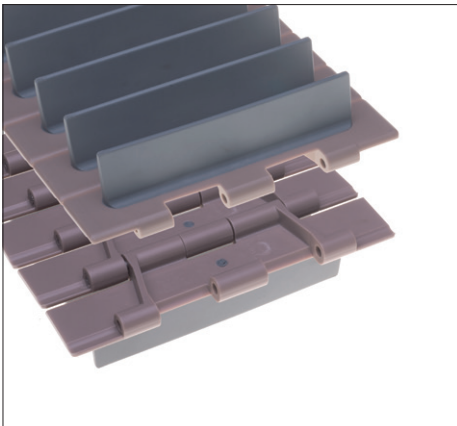

Chain Type	Code Number	Plate Width		Weight	Working Load (max.)	Backflex Radius (min)	Plate Thickness
		A					
		mm	inch	kg/m	N (21°C)	mm	mm
LF-Acetal							
LF821 RT-7.5IN D90 F38MM	10373788*	190.5	7.50	2.43	2680	70	4.8
LF821 SG-10IN D90 T1P F38MM	10400329*	254.0	10.00	2.85			
LF821 RT-12IN D90 F38MM	10373678*	304.8	12.00	3.17			

Standard length: 3.048 m – 10 feet (80 links).

The width (B) of the pushers varies per chain type:

151, 214 and 265 mm for respectively HFP 821-K750 F, HFP 821-K1000 F and HFP 821-K1200 F.

* Minimum order quantity 30.48 m – 100 feet.

Straight Run Double Hinge Supergrip

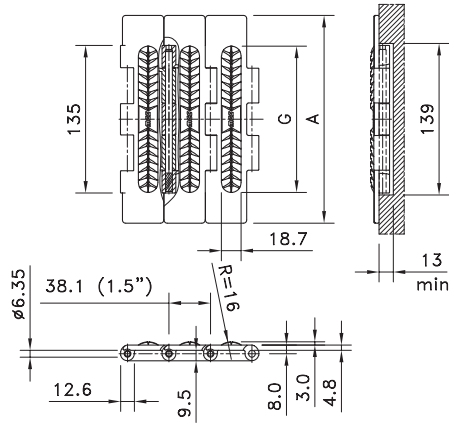
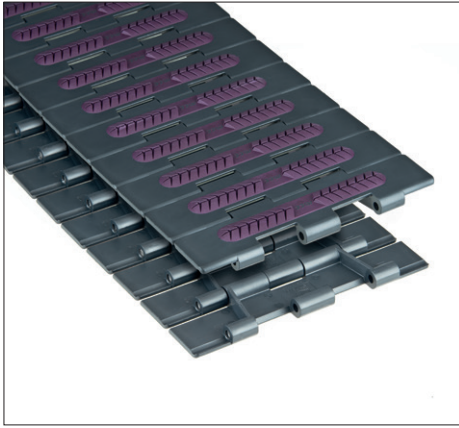

Chain Type	Code Number	Plate Width A		Weight kg/m	Working Load (max.) N (21°C)	Backflex Radius (min) mm	Plate Thickness mm
		mm	inch				
XLA-Acetal							
XLA_SWH SG-7.5IN	10144156	190.5	7.50	2.29	2680	50	4.8
XLA_SWH SG-10IN	10374884	254.0	10.00	2.67			
XLA_SWH SG-12IN	10144157	304.8	12.00	3.06			

Standard length: 3.048 m - 10 feet (80 links).

The width (G) of the moulded-in rubber top varies per chain type:

134, 192.1 and 252.5 mm for respectively SWH 750 SG, SWH 1000 SG and SWH 1200 SG.

Straight Run Double Hinge

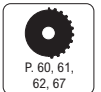
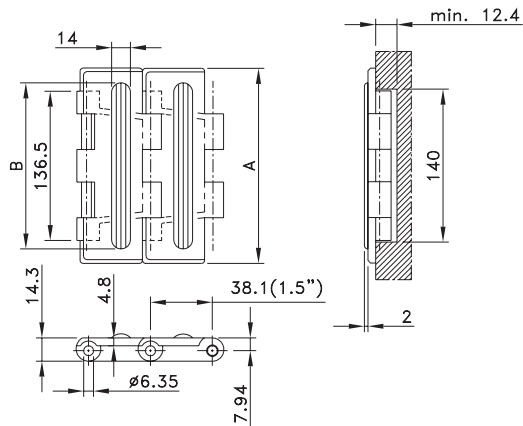
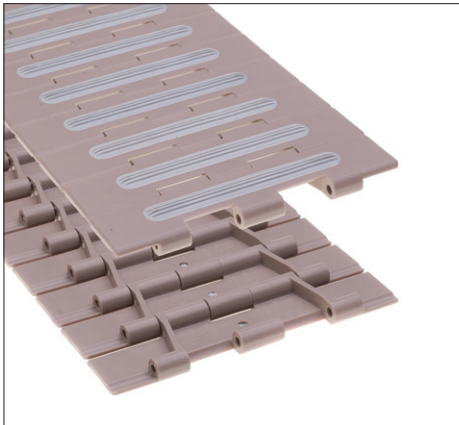

Chain Type	Code Number	Plate Width A		Weight kg/m	Working Load (max.) N (21°C)	Backflex Radius (min) mm	Plate Thickness mm
		mm	inch				
LF-Acetal							
LF821 SG-7.5IN D60 T1P	10383883*	190.5	7.50	2.50	2680	40	4.8
LF821 SG-10IN 1SGD60 T1P	10526960*	254.0	10.00	2.95			
LF821 SG-12IN 1SGD60 T1P	10526961*	304.8	12.00	3.25			

Standard length: 3.048 m - 10 feet (80 links).

The width (B) of the rubber varies per chain type:

132, 195 and 245 mm for respectively HFP 821-K750, HFP 821-K1000 and HFP 821-K1200.

* Minimum order quantity 30.48 m – 100 feet.

Straight Run Heavy Duty Supergrip

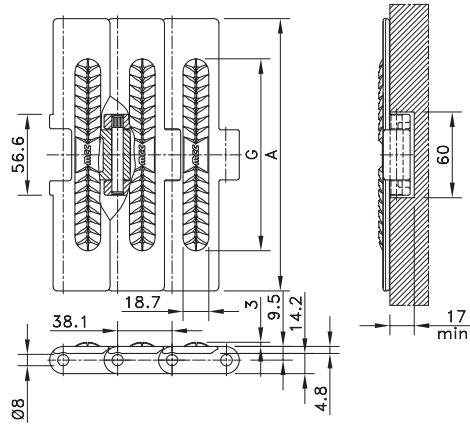
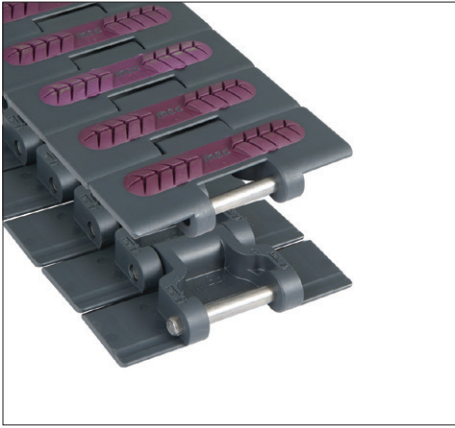

Chain Type	Code Number	Plate Width A		Weight kg/m	Working Load (max.) N (21°C)	Backflex Radius (min) mm	Plate Thickness mm
		mm	inch				
XLA-Acetal							
XLA_HDS SG-4.5IN	10374886	114.3	4.50	1.70	2700	50	4.8
XLA_HDS SG-7.5IN	10144159	190.5	7.50	2.10			
XLA_HDS SG-10IN	10144159	254.0	10.00	2.42			
XLA_HDS SG-12IN	10144160	304.8	12.00	2.69			

Standard length: 3.048 m - 10 feet (80 links).

The width (G) of the moulded-in rubber top varies per chain type:

92, 134, 192 and 252.5 mm for respectively HDS 450 SG, HDS 750 SG, HDS 1000 SG and HDS 1200 SG.

Magnetflex® Heavy Duty Supergrip

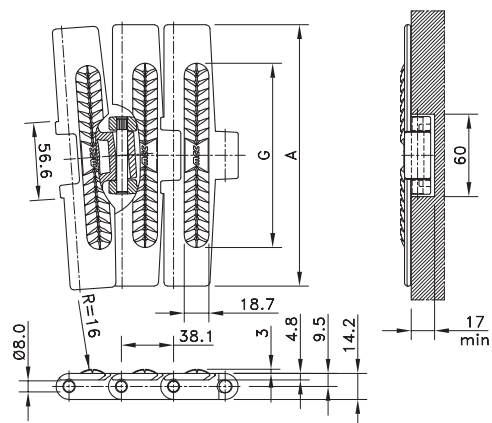
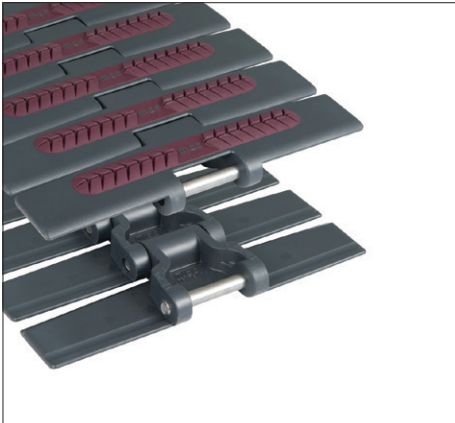

Chain Type	Code Number	Plate Width A		Weight kg/m	Sideflex Radius (min) mm	Working Load (max.) N (21°C)	Backflex Radius (min) mm	Plate Thickness mm
		mm	inch					
XLA-Acetal								
XLA_HDFM SG-7.5IN	10144158	190.5	7.50	2.10	610	2700	50	4.8
XLA_HDFM SG-10IN	10356786	254.0	10.00	2.42				
XLA_HDFM SG-12IN	10374885	304.8	12.00	2.69				

Standard length: 3.048 m - 10 feet (80 links).

The width (G) of the moulded-in rubber top varies per chain type:

134, 192 and 251 mm for respectively HDFM 750 SG, HDFM 1000 SG and HDFM 1200 SG.

Standard Radius Heavy Duty Single Hinge Tab

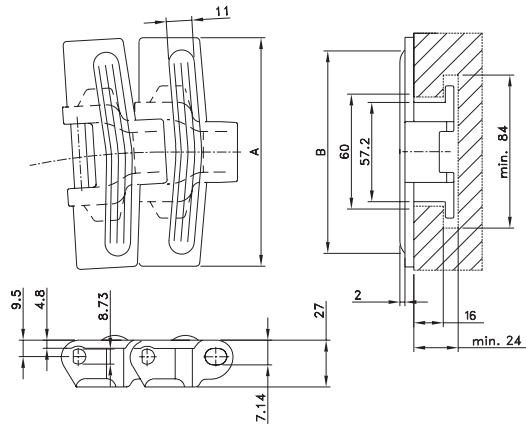
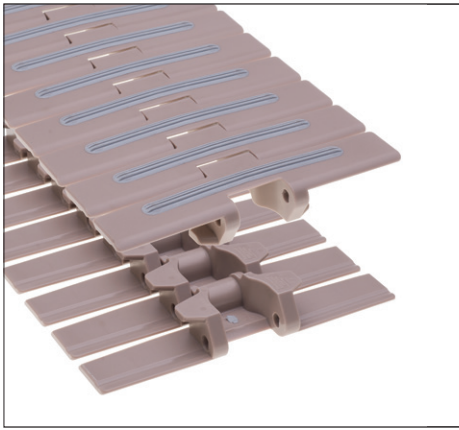

Chain Type	Code Number	Plate Width A		Weight kg/m	Sideflex Radius (min) mm	Working Load (max.) N (21°C)	Backflex Radius (min) mm	Plate Thickness mm
		mm	inch					
LF-Acetal								
LF882TAB SG-7.5IN D60	10374032	190.5	7.50	2.43	610	3830	40	4.8
LF882TAB SG-12IN D60 T1P	10374033	304.8	12.00	3.41				

Standard length: 3.048 m - 10 feet (80 links).
 The width (B) of the rubber varies per chain type:
 132, 195 and 246 mm for respectively HFP 882 TAB-K750, HFP 882 TAB-K1000 and HFP 882 TAB-K1200.
 Other rubber patterns and materials are possible.
 Minimum order quantity 30.48 m – 100 feet.

Standard Radius Single Hinge Tab

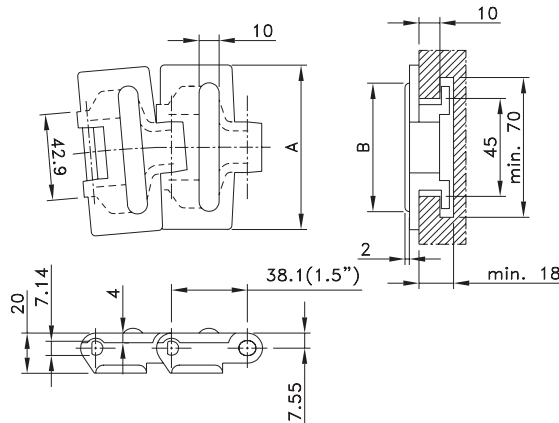
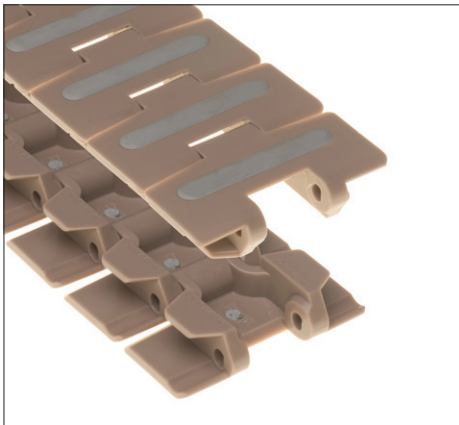

Chain Type	Code Number	Plate Width A		Weight kg/m	Sideflex Radius (min) mm	Working Load (max.) N (21°C)	Backflex Radius (min) mm	Plate Thickness mm
		mm	inch					
LF-Acetal								
LF880TAB RT-3.25IN D60 T1P	10481478	82.5	3.25	0.94	457	2100	40	4.0
LF880TAB RT-4.5IN SD60 T1P	10301143	114.3	4.50	1.08	500			

Standard length: 3.048 m - 10 feet (80 links).
 The width (B) of the rubber varies per chain type:
 65 and 95 mm for respectively HFP 880 TAB-K325 and HFP 880 TAB-K450.
 Other rubber patterns and materials are possible.
 * Minimum order quantity 30.48 m – 100 feet.

Small Radius Single Hinge Tab

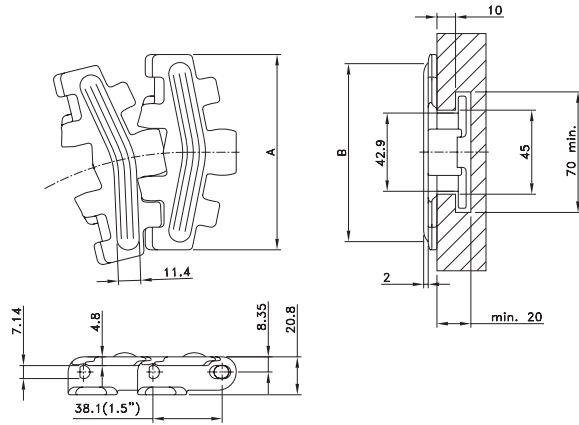
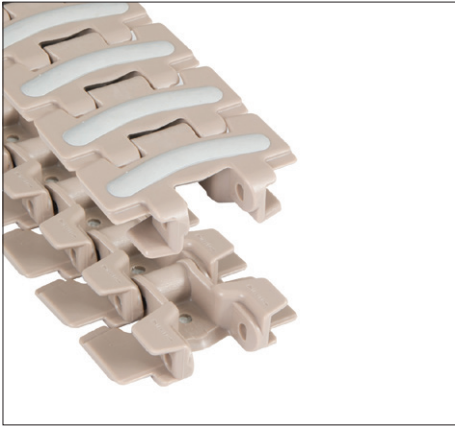

Chain Type	Code Number	Plate Width A		Weight kg/m	Working Load (max.) N (21°C)	Backflex Radius (min) mm	Sideflex Radius (min) mm	Plate Thickness mm
		mm	inch					
LF-Acetal								
LF879TAB BO RT-3.25IN D60 T1P	10373744	82.5	3.25	1.08	2100	40	190	4.8
LF879TAB BO RT-4.5IN D60 T1P	10177492	114.3	4.50	1.20				

Standard length: 3.048 m - 10 feet (80 links).
 The width (B) of the rubber varies per chain type:
 71 and 102 mm for respectively HFP 879 BO-K325 and HFP 879 BO-K450.
 Minimum order quantity 30.48 m – 100 feet.

Small Radius Single Hinge Tab

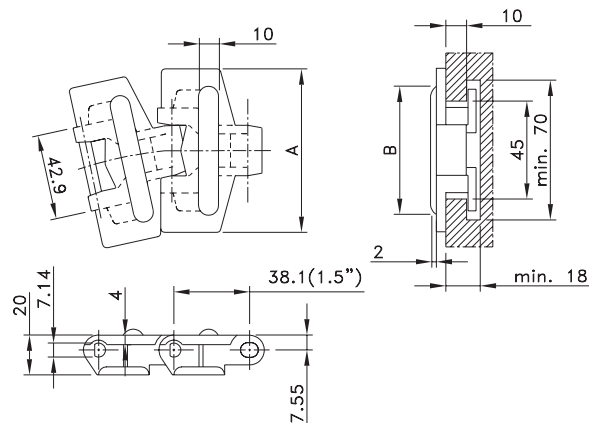
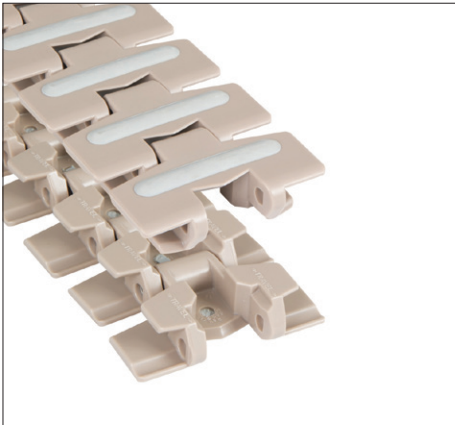

Chain Type	Code Number	Plate Width A		Weight kg/m	Working Load (max.) N (21°C)	Backflex Radius (min) mm	Sideflex Radius (min) mm	Plate Thickness mm
		mm	inch					
LF-Acetal								
LF880TAB BO RT-3.25IN D60	10373675	82.5	3.25	0.96	1680	40	190	4.0

Standard length: 3.048 m - 10 feet (80 links).
 The width (B) of the rubber is 65 mm.
 Other rubber patterns and materials are possible.
 * Minimum order quantity 30.48 m – 100 feet.

Straight Run Single Hinge LBP

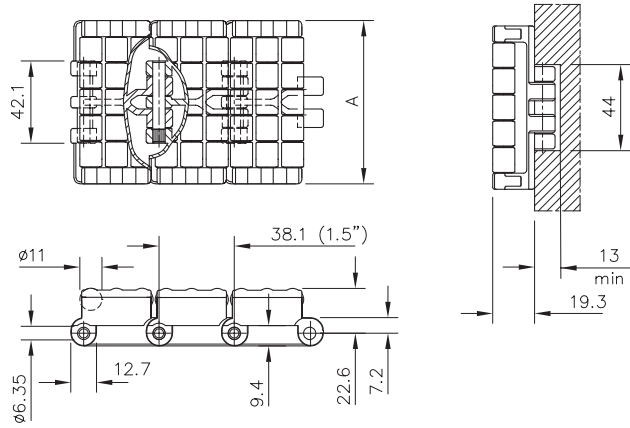

Chain Type	Code Number	Plate Width		Weight	Working Load (max.)	Backflex Radius (min)	Plate Thickness
		A					
		mm	inch	kg/m	N (21°C)	mm	mm
XLA-Acetal							
XLA_SHD LBP-3.25IN	10139137	82.5	3.25	2.20	1230	400	4.8

Standard length: 1.524 m - 5 feet (40 links).

Straight Run Double Hinge LBP

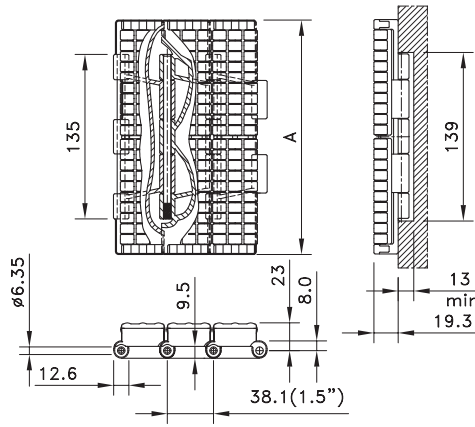

Chain Type	Code Number	Plate Width		Weight	Working Load (max.)	Backflex Radius (min)	Plate Thickness
		A					
		mm	inch	kg/m	N (21°C)	mm	mm
XLA-Acetal							
XLA_SWH LBP-7.5IN	10139134	190.5	7.50	5.30	2680	300	4.8
XLA_SWH LBP-10IN	10139136	254.0	10.00	6.60			
XLA_SWH LBP-12IN	10139135	304.8	12.00	7.85			

Standard length: 1.524 m - 5 feet (40 links).

Straight Run Heavy Duty LBP

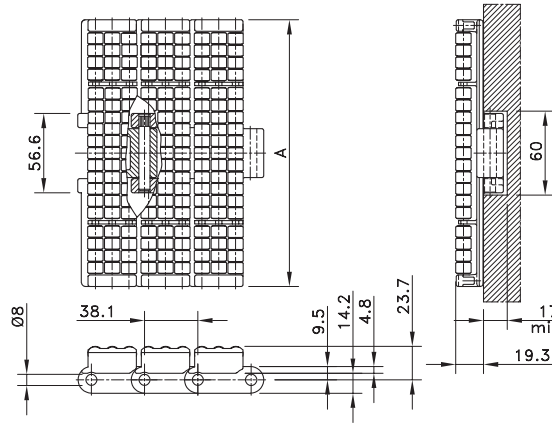
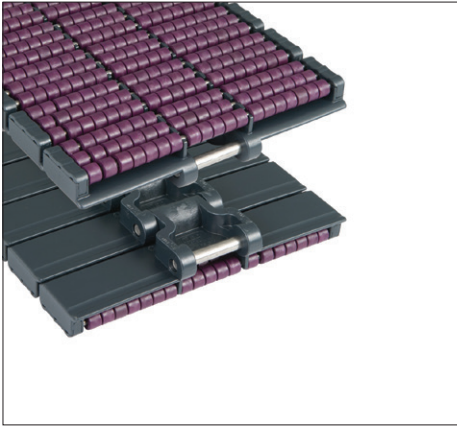

Chain Type	Code Number	Plate Width		Weight	Working Load (max.)	Backflex Radius (min)	Plate Thickness
		A					
		mm	inch	kg/m	N (21°C)	mm	mm
XLA-Acetal							
XLA_HDS LBP-7.5IN	10139131	190.5	7.50	4.28	3830	200	4.8

Standard length: 1.524 m - 5 feet (40 links).

Straight Run Heavy Duty LBP

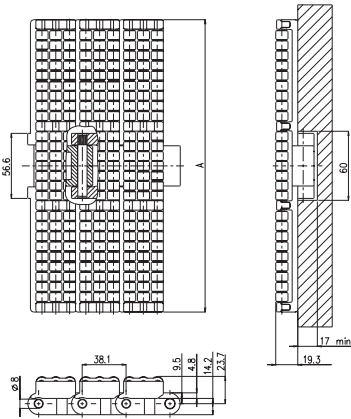
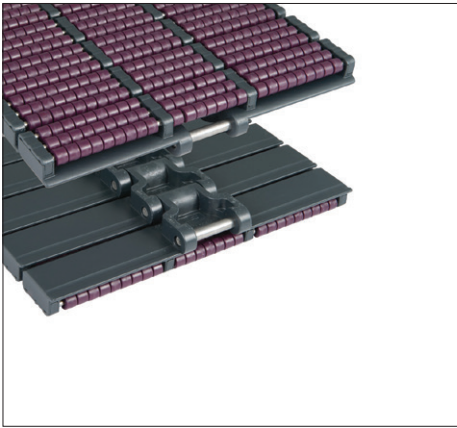

Chain Type	Code Number	Plate Width		Weight	Working Load (max.)	Backflex Radius (min)	Plate Thickness
		A					
		mm	inch	kg/m	N (21°C)	mm	mm
XLA-Acetal							
XLA_HDS LBP-10IN	10139132	254.0	10.00	5.23	3830	200	4.8
XLA_HDS LBP-12IN	10139133	304.8	12.00	5.83			

Standard length: 1.524 m – 5 feet (40 links).

Magnetflex® LBP

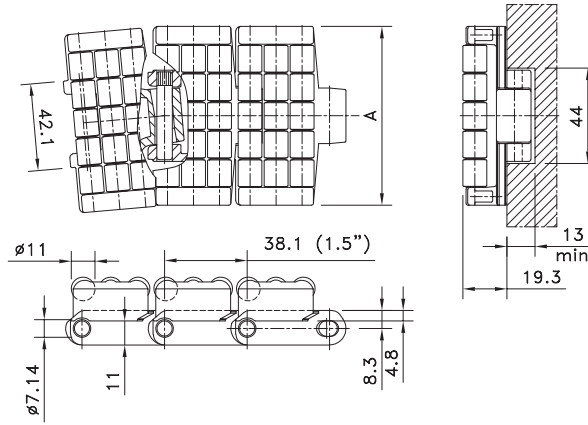

Chain Type	Code Number	Plate Width A		Weight kg/m	Sideflex Radius (min) mm	Working Load (max.) N (21°C)	Backflex Radius (min) mm	Plate Thickness mm
		mm	inch					
XLA-Acetal								
XLA_RHMD LBP-3.25IN	10139138	82.5	3.25	2.29	500	2100	400	4.8

Standard length: 1.524 m - 5 feet (40 links).

Magnetflex® Heavy Duty LBP

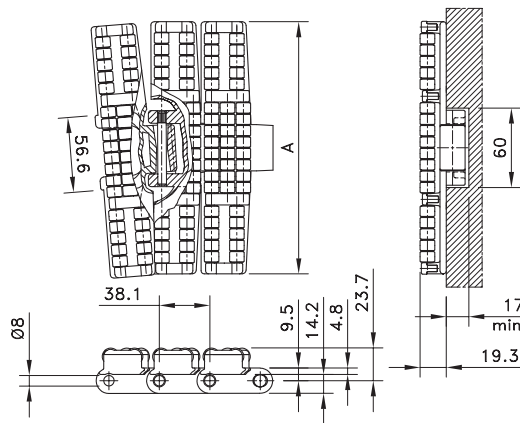
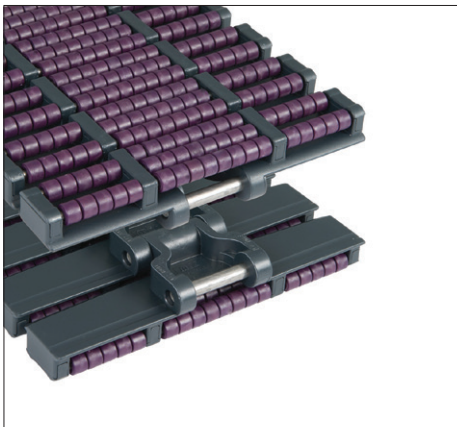

Chain Type	Code Number	Plate Width A		Weight kg/m	Sideflex Radius (min) mm	Working Load (max.) N (21°C)	Backflex Radius (min) mm	Plate Thickness mm
		mm	inch					
XLA-Acetal								
XLA_HDFM LBP-7.5IN	10139139	190.5	7.50	4.28	610	3830	200	4.8
XLA_HDFM LBP-10IN	10139140	254.0	10.00	5.23				
XLA_HDFM LBP-12IN	10139141	304.8	12.00	5.83				

Standard length: 1.524 m - 5 feet (40 links).

Standard Radius Single Hinge LBP

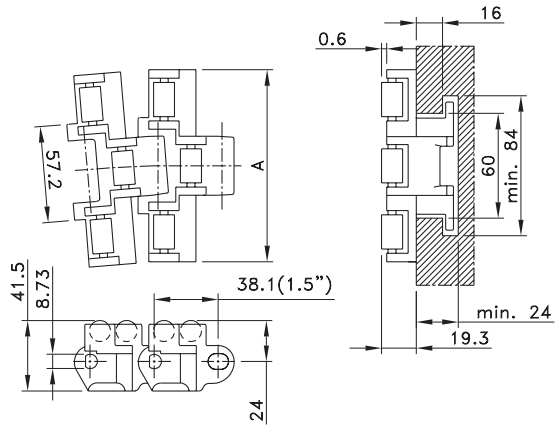
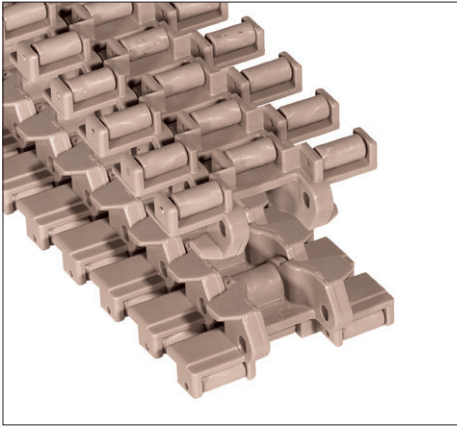

Chain Type	Code Number	Plate Width A		Weight kg/m	Sideflex Radius (min) mm	Working Load (max.) N (21°C)	Backflex Radius (min) mm	Plate Thickness mm
		mm	inch					
LF-Acetal								
LF883TAB LBP-4.5IN	10177547	114.3	4.50	2.50	610	3830	51	4.8
LF883TAB LBP-7.5IN	10177548	190.5	7.50	3.40				

Standard length: 3.048 m - 10 feet (80 links).

Small Radius Single Hinge Tab LBP

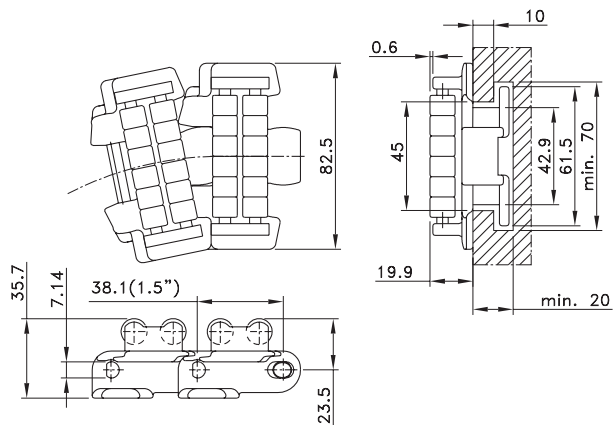
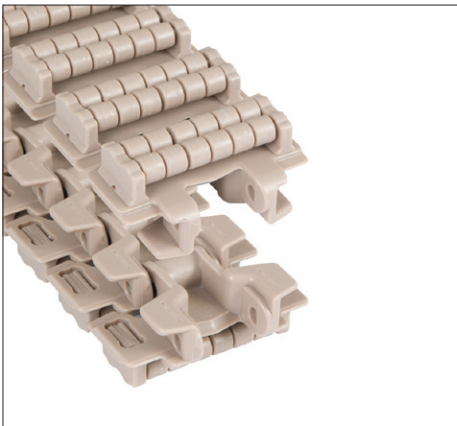

Chain Type	Code Number	Plate Width A		Weight kg/m	Sideflex Radius (min) mm	Working Load (max.) N (21°C)	Backflex Radius (min) mm	Plate Thickness mm
		mm	inch					
LF-Acetal								
LF879TAB BO LBP-3.25IN	10349805	82.5	3.25	1.08	200	2100	100	4.8

Standard length: 3.048 m - 10 feet (80 links).

* Minimum order quantity 30.48 m - 100 feet.

Sideflex Heavy Duty Tab LBP

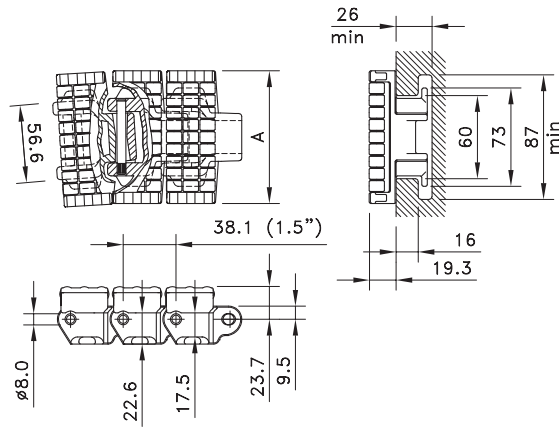
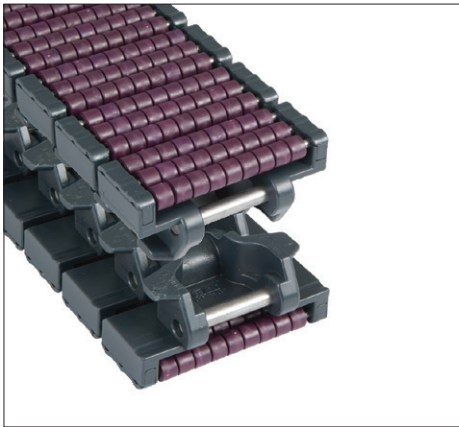

Chain Type	Code Number	Plate Width		Weight	Sideflex Radius (min)	Working Load (max.)	Backflex Radius (min)	Plate Thickness
		A						
		mm	inch	kg/m	mm	N (21°C)	mm	mm
XLA-Acetal								
XLA_HDF LBP-3.75IN	10139142	95.3	3.75	3.30	667	3830	200	4.8

Standard length: 1.524 m - 5 feet (40 links).

Sideflex Heavy Duty Tab LBP

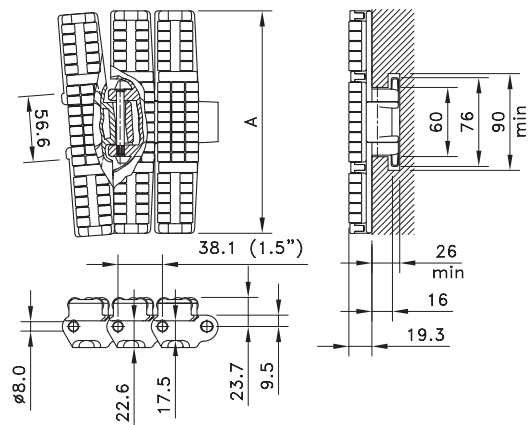
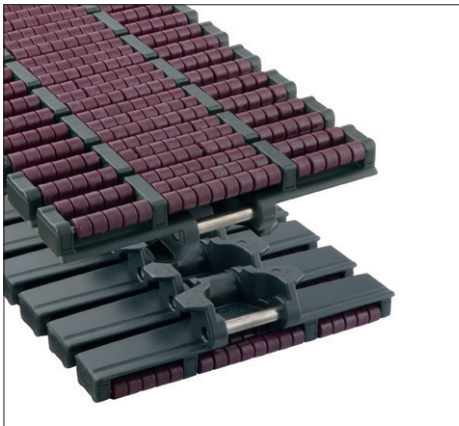

Chain Type	Code Number	Plate Width		Weight	Sideflex Radius (min)	Working Load (max.)	Backflex Radius (min)	Plate Thickness
		A						
		mm	inch	kg/m	mm	N (21°C)	mm	mm
XLA-Acetal								
XLA_HDF LBP-7.5IN	10139143	190.5	7.50	4.50	610	3830	200	4.8
XLA_HDF LBP-10IN	10139144	254.0	10.00	5.71				
XLA_HDF LBP-12IN	10139145	304.8	12.00	6.38	680			

Standard length: 1.524 m - 5 feet (40 links).

FlatTop Magnetflex 1040

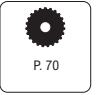
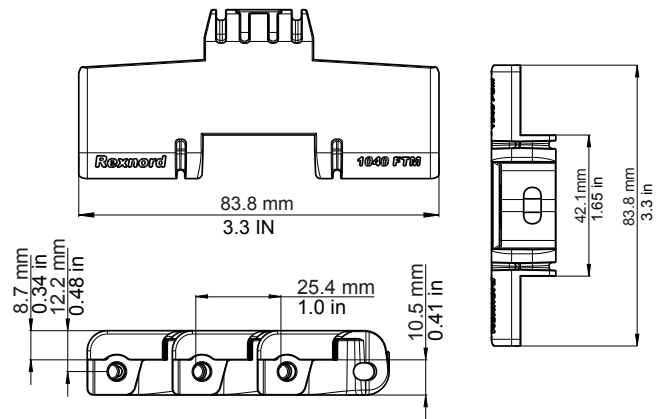
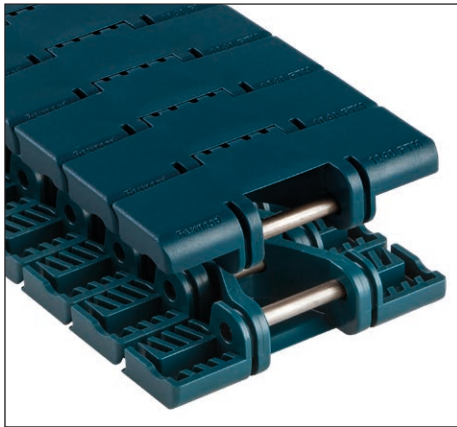

Rexnord 1040 Series Magnetflex TableTop Chain Material Overview

Chain Type	Material	Code Number	Working Load (max)	Weight	Backflex Radius (min)	Plate Thickness	Sideflex Radius (min)	Plate Width
			lbs / N	lbs/ft / kg/m	mm / in	mm / in	mm / in	mm / in
DRY-PT1040FTM-3.3IN	DRY-PT	10604554	337 / 1500	0.67 / 1.00	130.0 / 5.12	8.7 / 0.34	500 / 19.7	83.8 / 3.33
PSX1040FTM-3.3IN	PSX	10604578						
XLG1040FTM-3.3IN	XLG	10604555						
HP1040FTM-3.3IN	HP	10608553						
DKA1040FTM-3.3IN	DKA	10608551						

Flush Grid Magnetflex 1040

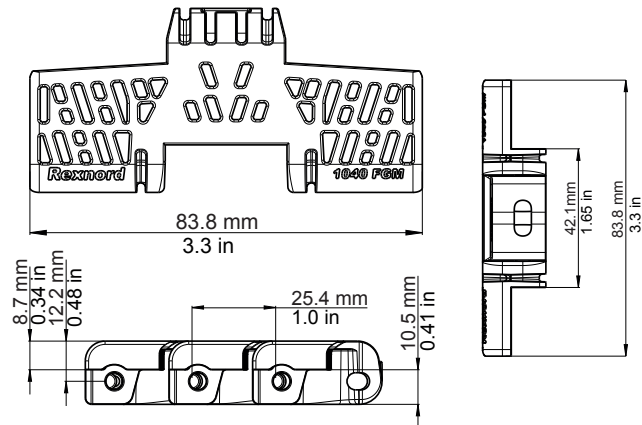
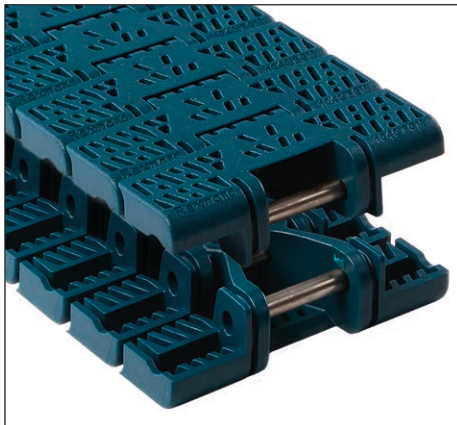

Rexnord 1040 Series Magnetflex Flush Grid TableTop Chain Material Overview

Chain Type	Material	Code Number	Working Load (max)	Weight	Backflex Radius (min)	Plate Thickness	Sideflex Radius (min)	Plate Width
			lbs / N	lbs/ft / kg/m	mm / in	mm / in	mm / in	mm / in
DRY-PT1040FGM-3.3IN	DRY-PT	10604582	337 / 1500	0.64 / 0.95	130.0 / 5.12	8.7 / 0.34	500 / 19.7	83.8 / 3.33
PSX1040FGM-3.3IN	PSX	10604586						
XLG1040FGM-3.3IN	XLG	10604583						
HP1040FGM-3.3IN	HP	10608555						
DKA1040FGM-3.3IN	DKA	10608554						

FlatTop Magnetflex® 1060

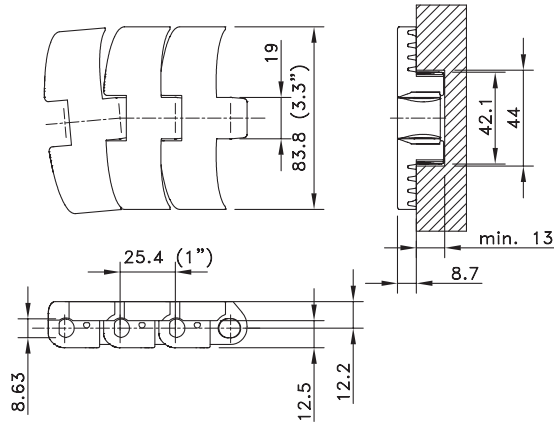
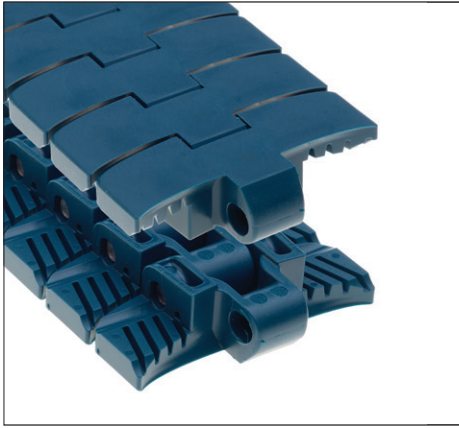

Chain Type	Code Number	Plate Width A		Weight kg/m	Sideflex Radius (min) mm	Working Load (max.) N (21°C)	Backflex Radius (min) mm	Plate Thickness mm
		mm	inch					
XLG-Acetal								
XLG1060FTM-3.3IN	10139063	83.8	3.30	1.68	500	1900	130	8.7
PSX Advanced Performance Polymer Alloy								
PSX1060FTM-3.3IN	10312036	83.8	3.30	1.68	500	1900	130	8.7
BWX-Polyamide Composite								
BWX1060FTM-3.3IN	10312036	83.8	3.30	1.68	500	1900	130	8.7

Standard length: 3.048 m - 10 feet (120 links).

FlatTop Magnetflex® 1055

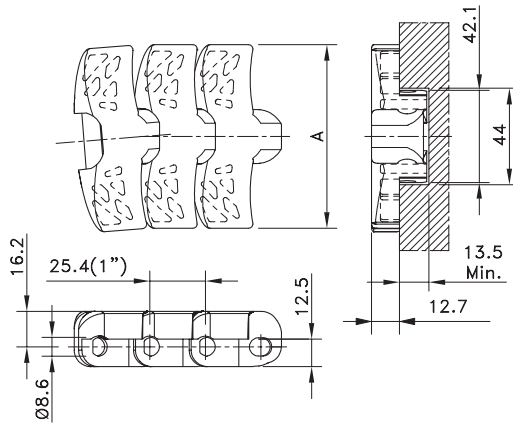
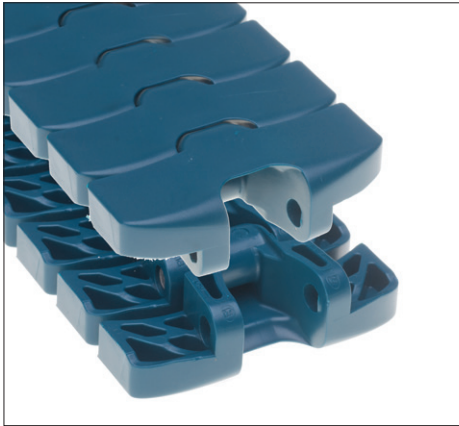

Chain Type	Code Number	Plate Width A		Weight kg/m	Sideflex Radius (min) mm	Working Load (max.) N (21°C)	Backflex Radius (min) mm	Plate Thickness mm
		mm	inch					
XLG-Acetal								
XLG1055FTM-3.3IN	10375089	83.8	3.30	1.90	500	2200	130	12.7
XLG1055FTM-4.5IN	10186163	114.3	4.50	2.20				
PSX Advanced Performance Polymer Alloy								
PSX1055FTM-3.3IN	10375002	83.8	3.30	1.90	500	2200	130	12.7
BWX-Polyamide Composite								
BWX1055FTM-3.3IN	10375088	83.8	3.30	1.90	500	2200	130	12.7
BWX1055FTM-4.5IN	10375098	114.3	4.50	2.20				

Standard length: 3.048 m - 10 feet (120 links).

FlatTop 1050 TAB

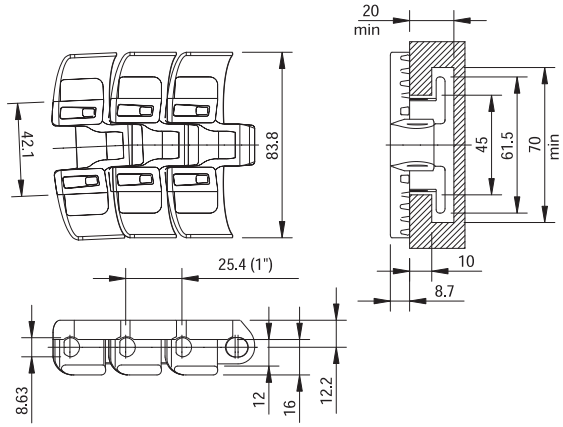
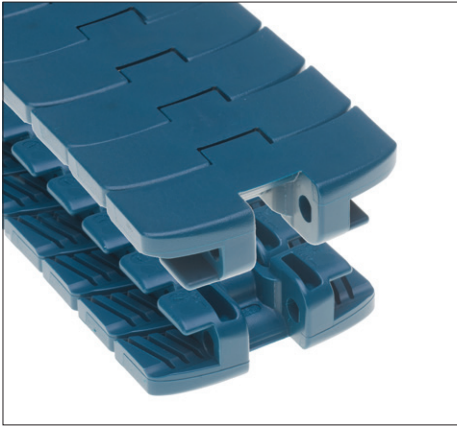

Chain Type	Code Number	Plate Width A		Weight kg/m	Sideflex Radius (min) mm	Working Load (max.) N (21°C)	Backflex Radius (min) mm	Plate Thickness mm
		mm	inch					
XLG-Acetal								
XLG1050FTTAB-3.3IN	10375093	83.8	3.30	1.93	500	1650	130	8.7
BWX-Polyamide Composite								
BWX1050FTTAB-3.3IN	10375179	83.8	3.30	1.93	500	1650	130	8.7

Standard length: 3.048 m - 10 feet (120 links).

FlatTop 1055 TAB

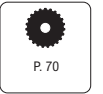
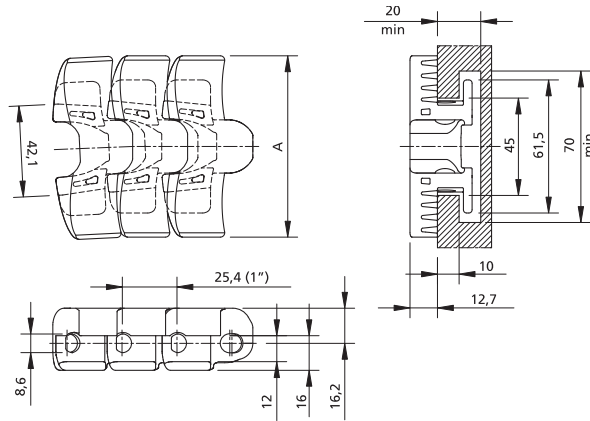

Chain Type	Code Number	Plate Width A		Weight kg/m	Sideflex Radius (min) mm	Working Load (max.) N (21°C)	Backflex Radius (min) mm	Plate Thickness mm
		mm	inch					
XLG-Acetal								
XLG1055FTTAB-3.3IN	10139075	83.8	3.30	2.13	500	2200	130	12.7
XLG1055FTTAB-4.5IN	10374992	114.3	4.50	2.30	500	2200	130	12.7
BWX-Polyamide Composite								
BWX1055FTTAB-3.3IN	10463352	83.8	3.30	2.13	500	2200	130	12.7
BWX1055FTTAB-4.5IN	10375000	114.3	4.50	2.30	500	2200	130	12.7

Standard length: 3.048 m - 10 feet (120 links).

Sideflex Tab Heavy Duty

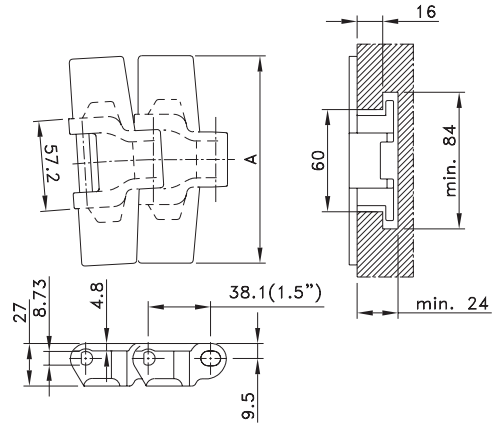
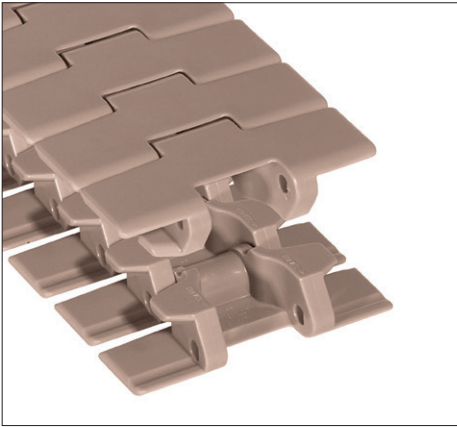

Chain Type	Code Number	Plate Width A		Weight kg/m	Sideflex Radius (min) mm	Working Load (max.) N (21°C)	Backflex Radius (min) mm	Plate Thickness mm
		mm	inch					
LF-Acetal								
LF882TAB-3.25IN*	10144749	82.5	3.25	1.86	610	3830	40	4.8
LF882TAB-4.5IN	10177754	114.3	4.50	1.98				
LF882TAB-7.5IN	10177755	190.5	7.50	2.43				
LF882TAB-10IN	10177756	254.0	10.00	2.87				
LF882TAB-12IN	10177757	304.8	12.00	3.41				

Standard length: 3.048 m – 10 feet (80 links).

* Minimum order quantity 30.48 m – 100 feet.

NS815

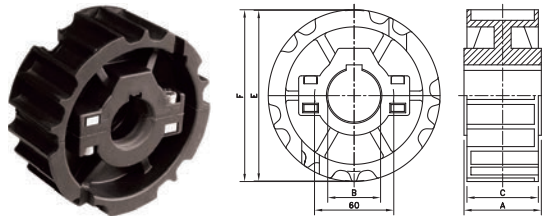

Sprocket Type	Code Number	Number of Teeth	Bore	Pitch Diameter	Outside Diameter	Width (Teeth)	Hub Width	Hub Diameter
			B	E	F	C	A	H
			mm/inch	mm	mm	mm	mm	mm

Split Sprockets, Injection Moulded - NS 815

Metric Bores								
NS815-21T_25MM_1KW_PA	10334394	21	25	129.3	129.5	52	51	60
NS815-21T_30MM_1KW_PA	10334395	21	30					
NS815-21T_35MM_1KW_PA	10334396	21	35					
NS815-21T_40MM_1KW_PA	10334397	21	40					
NS815-21T_45MM_1KW_PA	10334398	21	45					
NS815-23T_25MM_1KW_PA	10334400	23	25	141.2	142.0	54.0	58.5	
NS815-23T_30MM_1KW_PA	10334401	23	30					
NS815-23T_35MM_1KW_PA	10334402	23	35					
NS815-23T_40MM_1KW_PA	10334403	23	40					
NS815-23T_45MM_1KW_PA	10334404	23	45	153.2	154.2	54.0	58.5	
NS815-25T_25MM_1KW_PA	10334406	25	25					
NS815-25T_30MM_1KW_PA	10131628	25	30					
NS815-25T_35MM_1KW_PA	10131629	25	35					
NS815-25T_40MM_1KW_PA	10334409	25	40					
NS815-25T_45MM_1KW_PA	10334410	25	45					

Inch Bores								
NS815-21T_1IN_1KW_PA	10177474	21	1.00"	129.3	129.5	52.0	51.0	60
NS815-21T_1-1/4IN_1KW_PA	10328297	21	1.25"					
NS815-23T_1IN_1KW_PA	10403007	23	1.00"					
NS815-23T_1-1/4IN_1KW_PA	10328298	23	1.25"	141.2	142.0	54.0	58.5	
NS815-25T_1IN_1KW_PA	10609043	25	1.00"					
NS815-25T_1-1/4IN_1KW_PA	10328299	25	1.25"	153.2	154.2	54.0	58.5	
NS815-25T_1-1/2IN_1KW_PA	10328188	25	1.50"					

For steel chain series: **Rexnord:** 812 (except TAB and mini hinge), 815.
 single hinge straight run, single hinge Magnetflex. Note: not for heavy duty tab.
 * Ask customer service for minimum order quantity.

NSH815

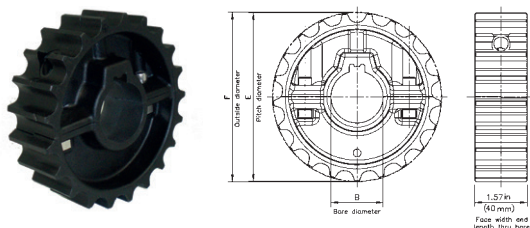

Sprocket Type	Code Number	Number of Teeth	Pitch Diameter	Outside Diameter	Width	Hub Width	Shaft Size	Equivalent of KUS 815
			in-mm	in-mm	in-mm	in-mm	in-mm	

Split moulded sprocket NSH 815

NSH815-21T_30MM_1KW_PA	10330167	21	5.09 / 129.3	5.11 / 130.0	1.57 / 40	1.57 / 40	1.18 / 30	753.62.23
NSH815-21T_40MM_1KW_PA	10330169	21	5.09 / 129.3	5.11 / 130.0	1.57 / 40	1.57 / 40	1.57 / 40	753.62.43
NSH815-25T_40MM_1KW_PA	10330165	25	6.03 / 153.2	6.05 / 153.9	1.57 / 40	1.57 / 40	1.57 / 40	753.62.45

Split moulded sprocket NSH 815 with M8 setscrew

NSH815-21T_30MM_1KW1SS_PA	10330168	21	5.09 / 129.3	5.11 / 130.0	1.57 / 40	1.57 / 40	1.18 / 30	753.62.23
NSH815-21T_40MM_1KW1SS_PA	10330170	21	5.09 / 129.3	5.11 / 130.0	1.57 / 40	1.57 / 40	1.57 / 40	753.62.43
NSH815-25T_40MM_1KW1SS_PA	10330166	25	6.03 / 153.2	6.05 / 153.9	1.57 / 40	1.57 / 40	1.57 / 40	753.62.45

KUS815

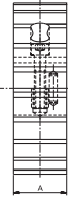
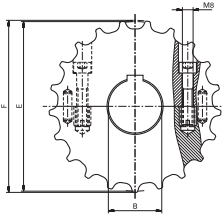

Sprocket Type	Code Number	Number of Teeth	Bore	Pitch Diameter	Outside Diameter	Width (Teeth)	Hub Width	Hub Diameter
			B	E	F	C	A	H
			mm	mm	mm	mm	mm	mm

Split Sprockets And Idlers, Machined - KUS 815

Sprockets, Metric Bores

KUS815-17T_25MM_1KW_PA	10331076	17	25	105.5	104.5	40.0	40.0	-
KUS815-17T_30MM_1KW_PA	10331476	17	30					
KUS815-17T_35MM_1KW_PA	10331829	17	35					
KUS815-17T_40MM_1KW_PA	10332190	17	40					
KUS815-19T_25MM_1KW_PA	10332190	19	25	117.3	116.3			
KUS815-19T_30MM_1KW_PA	10139146	19	30					
KUS815-19T_35MM_1KW_PA	10331831	19	35					
KUS815-19T_40MM_1KW_PA	10331831	19	40					
KUS815-19T_40MM_1KW_PA	10359781	19	50	129.3	130.0			
KUS815-19T_40MM_1KW_PA	10331080	21	25					
KUS815-21T_30MM_1KW_PA	10331080	21	30					
KUS815-21T_35MM_1KW_PA	10331080	21	35					
KUS815-21T_40MM_1KW_PA	10332194	21	40	141.2	141.9			
KUS815-21T_50MM_1KW_PA	10332194	21	50					
KUS815-23T_25MM_1KW_PA	10331082	23	25					
KUS815-23T_30MM_1KW_PA	10139148	23	30					
KUS815-23T_35MM_1KW_PA	10331835	23	35	153.2	153.9			
KUS815-23T_40MM_1KW_PA	10332196	23	40					
KUS815-23T_50MM_1KW_PA	10332815	23	50					
KUS815-25T_25MM_1KW_PA	10331084	25	25					
KUS815-25T_30MM_1KW_PA	10331484	25	30	165.2	165.9			
KUS815-25T_35MM_1KW_PA	10331837	25	35					
KUS815-25T_40MM_1KW_PA	10139149	25	40					
KUS815-25T_50MM_1KW_PA	10332817	25	50					
KUS815-27T_25MM_1KW_PA	10331086	27	25	165.2	165.9			
KUS815-27T_30MM_1KW_PA	10331486	27	30					
KUS815-27T_35MM_1KW_PA	10331839	27	35					
KUS815-27T_40MM_1KW_PA	10332200	27	40					
KUS815-27T_50MM_1KW_PA	10332819	27	50					

Idlers, Metric Bores

KUS815-17T_25MM_I_PA	10331077	17	25	105.5	104.5	40.0	40.0	-
KUS815-17T_30MM_I_PA	10331477	17	30					
KUS815-17T_35MM_I_PA	10331830	17	35					
KUS815-17T_40MM_I_PA	10332191	17	40					
KUS815-19T_25MM_I_PA	10331079	19	25	117.3	116.3			
KUS815-19T_30MM_I_PA	10331479	19	30					
KUS815-19T_35MM_I_PA	10331832	19	35					
KUS815-19T_40MM_I_PA	10332193	19	40					
KUS815-19T_50MM_I_PA	10359768	19	50	129.3	130.0			
KUS815-21T_25MM_I_PA	10331081	21	25					
KUS815-21T_30MM_I_PA	10331481	21	30					
KUS815-21T_35MM_I_PA	10331834	21	35					
KUS815-21T_40MM_I_PA	10332195	21	40	141.2	141.9			
KUS815-21T_50MM_I_PA	10332814	21	50					
KUS815-23T_25MM_I_PA	10331083	23	25					
KUS815-23T_30MM_I_PA	10331483	23	30					
KUS815-23T_35MM_I_PA	10331836	23	35	141.2	141.9			
KUS815-23T_40MM_I_PA	10332197	23	40					
KUS815-23T_50MM_I_PA	10332816	23	50					

KUS815

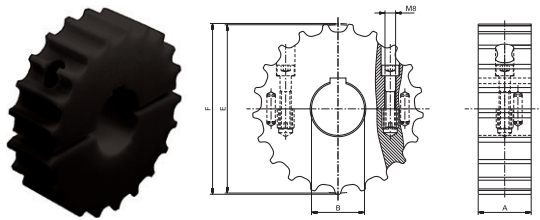

KU815

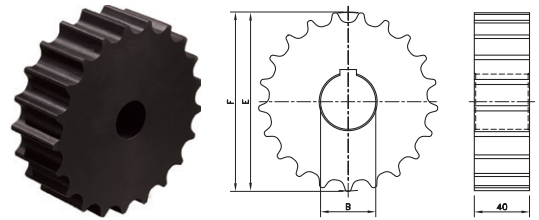

Sprocket Type	Code Number	Number of Teeth	Bore	Pitch Diameter	Outside Diameter	Width (Teeth)	Hub Width	Hub Diameter
			B	E	F	C	A	H
			mm	mm	mm	mm	mm	mm

Idlers, Metric Bores continued

KUS815-25T_25MM_I_PA	10331085	25	25	153.2	153.9	40.0	40.0	-
KUS815-25T_30MM_I_PA	10331485	25	30					
KUS815-25T_35MM_I_PA	10331838	25	35					
KUS815-25T_40MM_I_PA	10332199	25	40					
KUS815-25T_50MM_I_PA	10332818	25	50					
KUS815-27T_25MM_I_PA	10331087	27	25	165.2	165.9	40.0	40.0	-
KUS815-27T_30MM_I_PA	10331487	27	30					
KUS815-27T_35MM_I_PA	10331840	27	35					
KUS815-27T_40MM_I_PA	10332201	27	40					
KUS815-27T_50MM_I_PA	10332820	27	50					

For steel chain series: **Rexnord**: 812 (except TAB and mini hinge), 815.
single hinge straight run, single hinge Magnetflex, 66 ST 75 RM.

Classic Sprockets, Machined - KU 815

Metric Bores

KU815-17T_20MM_P_PA	10297045	17	20*	105.5	104.5	40	-	-
KU815-19T_20MM_P_PA	10297046	19	20*	117.3	116.3			
KU815-21T_20MM_P_PA	10297047	21	20*	129.3	130.0			
KU815-23T_20MM_P_PA	10297048	23	20*	141.2	141.9			
KU815-25T_20MM_P_PA	10297049	25	20*	153.2	153.9			
KU815-27T_20MM_P_PA	10297050	27	20*	165.2	165.9			

*Pre-bore

For steel chain series: **Rexnord**: 812 (except TAB and mini hinge), 815.
single hinge straight run, single hinge Magnetflex, 66 ST 75 RM.

NSH820

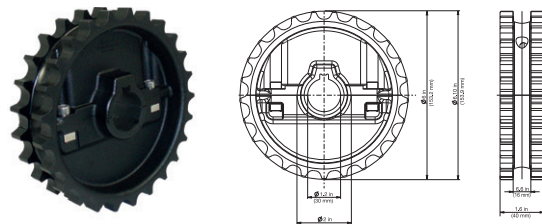

Sprocket Type	Code Number	Number of Teeth	Pitch Diameter	Outside Diameter	Width	Hub Width	Shaft Size	Equivalent to NS 820	Equivalent to NS 831
			in-mm	in-mm	in-mm	in-mm	in-mm		
NSH820-25T_25MM_1KW_PA	10334525	25	6.0 / 153.2	6.1 / 154.2	1.50 / 38	1.6 / 40	0.98 / 25	L0820665361	L0831604202
NSH820-25T_30MM_1KW_PA	10334526	25	6.0 / 153.2	6.1 / 154.2	1.65 / 42	1.6 / 40	1.18 / 30	L0820665371	L0831604212
NSH820-25T_35MM_1KW_PA	10334527	25	6.0 / 153.2	6.1 / 154.2	1.85 / 47	1.6 / 40	1.37 / 35	L0820665381	L0831604222
NSH820-25T_40MM_1KW_PA	10334528	25	6.0 / 153.2	6.1 / 154.2	2.05 / 52	1.6 / 40	1.57 / 40	L0820665391	L0831604232
NSH820-25T_45MM_1KW_PA	10334529	25	6.0 / 153.2	6.1 / 154.2	2.25 / 57	1.6 / 40	1.77 / 45	L0820665401	L0831604242

NS820

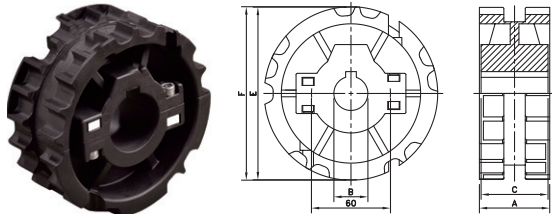

N820

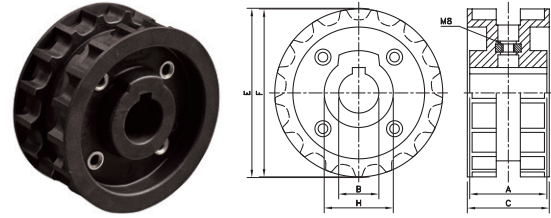

Sprocket Type	Code Number	Number of Teeth	Bore	Pitch Diameter	Outside Diameter	Width (Teeth)	Hub Width	Hub Diameter
			B	E	F	C	A	H
			mm/inch	mm	mm	mm	mm	mm

Split Sprockets, Injection Moulded - NS 820

Metric Bores								
NS820-21T_25MM_1KW_PA	10334413	21	25	129.3	129.5	52.0	51.0	60
NS820-21T_30MM_1KW_PA	10028632	21	30	129.3	129.5	52.0	51.0	
NS820-21T_35MM_1KW_PA	10334415	21	35	129.3	129.5	52.0	51.0	
NS820-21T_40MM_1KW_PA	10334416	21	40	129.3	129.5	52.0	51.0	
NS820-21T_45MM_1KW_PA	10334417	21	45	129.3	129.5	52.0	51.0	
NS820-23T_25MM_1KW_PA	10334418	23	25	141.2	142.0	52.0	51.0	
NS820-23T_30MM_1KW_PA	10028637	23	30	141.2	142.0	52.0	51.0	
NS820-23T_35MM_1KW_PA	10334421	23	35	141.2	142.0	52.0	51.0	
NS820-23T_40MM_1KW_PA	10334422	23	40	141.2	142.0	52.0	51.0	
NS820-23T_45MM_1KW_PA	10334423	23	45	141.2	142.0	52.0	51.0	
NS820-25T_25MM_1KW_PA	10334424	25	25	153.2	154.2	54.0	58.5	
NS820-25T_30MM_1KW_PA	10028648	25	30	153.2	154.2	54.0	58.5	
NS820-25T_35MM_1KW_PA	10334427	25	35	153.2	154.2	54.0	58.5	
NS820-25T_40MM_1KW_PA	10334428	25	40	153.2	154.2	54.0	58.5	
NS820-25T_45MM_1KW_PA	10334429	25	45	153.2	154.2	54.0	58.5	
Inch Bores*								
NS820-21T_1IN_1KW_PA	10328037	21	1.00"	129.3	129.5	52.0	51.0	60
NS820-21T_1-1/4IN_1KW_PA	10328300	21	1.25"	129.3	129.5	52.0	51.0	
NS820-23T_1IN_1KW_PA	10328038	23	1.00"	141.2	142.0	52.0	51.0	
NS820-23T_1-1/4IN_1KW_PA	10328301	23	1.25"	141.2	142.0	52.0	51.0	
NS820-25T_1IN_1KW_PA	10328039	25	1.00"	153.2	154.2	54.0	58.5	
NS820-25T_1-1/4IN_1KW_PA	10328302	25	1.25"	153.2	154.2	54.0	58.5	

For steel chain series (optional): Rexnord: 812 (except TAB and mini hinge), 815. single hinge straight run, single hinge Magnetflex.

For plastic chain series: 820, SH; Note: not suitable for 831.

* Ask Customer service for minimum order quantity of sprockets with inch bores.

Classic Sprockets, Injection Moulded - N 820

Metric Bores								
N820-15T_25MM_1KW_PA	10334334	15	25	93.7	92.2	50.0	50.0	43
N820-15T_30MM_1KW_PA	10334335	15	30	93.7	92.2	50.0	50.0	43
N820-17T_25MM_1KW_PA	10334336	17	25	105.5	104.7	51.0	48.0	43
N820-17T_30MM_1KW_PA	10177482	17	30	105.5	104.7	51.0	48.0	43
N820-19T_20MM_1KW_PA	10334338	19	20	117.4	117.1	50.0	50.0	60
N820-19T_25MM_1KW_PA	10177483	19	25	117.4	117.1	50.0	50.0	60
N820-19T_30MM_1KW_PA	10177484	19	30	117.4	117.1	50.0	50.0	60
N820-19T_35MM_1KW_PA	10334341	19	35	117.4	117.1	50.0	50.0	60
N820-19T_40MM_1KW_PA	10334342	19	40	117.4	117.1	50.0	50.0	60

For steel chain series (optional): Rexnord: 812 (except TAB and mini hinge), 815. single hinge straight run, single hinge Magnetflex.

For plastic chain series: 820, SH; Note: not suitable for 831.

NT820

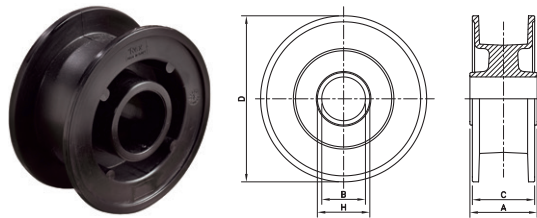

NST820

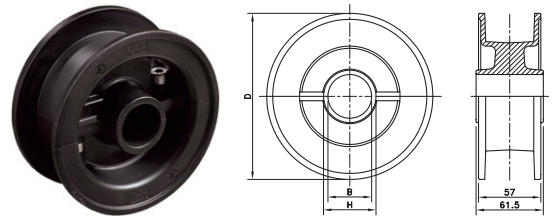

Sprocket Type	Code Number	Number of Teeth	Bore	Outside Diameter	Width (Teeth)	Hub Width	Hub Diameter
			B	F	C	A	H
			mm/inch	mm	mm	mm	mm

Classic Idler Drums, Injection Moulded - NT 820

Metric Bores							
NT820-15T_25MM_I_PA	10334543	15	25	95.5	55.0	92.0	40
NT820-15T_30MM_I_PA	10334544	15	30	95.5	55.0	92.0	40
NT820-17T_25MM_I_PA	10334545	17	25	106.5	53.0	57.0	42
NT820-17T_30MM_I_PA	10334546	17	30	106.5	53.0	57.0	42
NT820-18T_25MM_I_PA	10334547	18	25	113.0	57.0	92.0	40
NT820-18T_30MM_I_PA	10334548	18	30	113.0	57.0	92.0	40
NT820-19T_25MM_I_PA	10334549	19	25	118.0	57.0	57.0	42
NT820-19T_30MM_I_PA	10177481	19	30	118.0	57.0	57.0	42
NT820-19T_40MM_I_PA	10334551	19	40	118.0	57.0	57.0	51
NT820-21T_25MM_I_PA	10297306	21	25	130.0	60.0	61.5	35
NT820-21T_30MM_I_PA	10297307	21	30	130.0	60.0	61.5	40
NT820-21T_35MM_I_PA	10334554	21	35	130.0	60.0	61.5	45
NT820-21T_40MM_I_PA	10334555	21	40	130.0	60.0	61.5	50
NT820-23T_25MM_I_PA	10334556	23	25	142.5	59.5	61.5	35
NT820-23T_30MM_I_PA	10297300	23	30	142.5	59.5	61.5	40
NT820-23T_35MM_I_PA	10298169	23	35	142.5	59.5	61.5	45
NT820-23T_40MM_I_PA	10334559	23	40	142.5	59.5	61.5	50
NT820-25T_25MM_I_PA	10297295	25	25	154.5	59.0	61.5	35
NT820-25T_30MM_I_PA	10334561	25	30	154.5	59.0	61.5	40
NT820-25T_35MM_I_PA	10334562	25	35	154.5	59.0	61.5	45
NT820-25T_40MM_I_PA	10334563	25	40	154.5	59.0	61.5	50

Inch Bores

NT820-21T_1IN_I_PA	10328540	21	1.00"	130.0	60.0	61.5	35
NT820-21T_1-1/4IN_I_PA	10328545	21	1.25"	130.0	60.0	61.5	40
NT820-21T_1-1/2IN_I_PA	10328542	21	1.50"	130.0	60.0	61.5	45
NT820-23T_1-1/4IN_I_PA	10319215	23	1.25"	142.5	59.5	61.5	40
NT820-23T_1-1/2IN_I_PA	10328543	23	1.50"	142.5	59.5	61.5	45
NT820-25T_1IN_I_PA	10328541	25	1.00"	154.5	59.0	61.5	35
NT820-25T_1-1/4IN_I_PA	10328547	25	1.25"	154.5	59.0	61.5	40
NT820-25T_1-1/2IN_I_PA	10328544	25	1.50"	154.5	59.0	61.5	45

For steel chain series: **Rexnord:** 812 (except TAB and mini hinge), 815, 881 (except TAB), 8811 (except TAB), single hinge straight run, single hinge Magnetflex.

For plastic chain series: 879-Bevel, 880-Bevel, 820, 831, SH, SHD, RHM, RHMD, RHMP, RHMDP, SHP.

Split Idler Drums, Injection Moulded - NST 820

Metric Bores							
NST820-21T_25MM_I_PA	10334530	21	25	130.0	57.0	61.5	40
NST820-21T_30MM_I_PA	10318282	21	30	130.0	57.0	61.5	40
NST820-21T_35MM_I_PA	10291542	21	35	130.0	57.0	61.5	50
NST820-21T_40MM_I_PA	10288598	21	40	130.0	57.0	61.5	50
NST820-23T_25MM_I_PA	10334534	23	25	142.5	57.0	61.5	40
NST820-23T_30MM_I_PA	10334535	23	30	142.5	57.0	61.5	40
NST820-23T_35MM_I_PA	10334536	23	35	142.5	57.0	61.5	50
NST820-23T_40MM_I_PA	10334537	23	40	142.5	57.0	61.5	50
NST820-25T_25MM_I_PA	10334538	25	25	154.5	57.0	61.5	35
NST820-25T_30MM_I_PA	10350819	25	30	154.5	57.0	61.5	40
NST820-25T_35MM_I_PA	10334540	25	35	154.5	57.0	61.5	45
NST820-25T_40MM_I_PA	10334541	25	40	154.5	57.0	61.5	50
NST820-25T_45MM_I_PA	10334542	25	45	154.5	57.0	61.5	50

Sprocket Type	Code Number	Number of Teeth	Bore	Pitch Diameter	Outside Diameter	Width (Teeth)	Hub Width	Hub Diameter
			B	E	F	C	A	H
			mm/inch	mm	mm	mm	mm	mm

Split Idler Drums, Injection Moulded - NST 820 continued

Inch Bores*								
NST820-21T_1IN_I_PA	10328533	21	1.00"	--	130.0	57.0	61.5	40
NST820-21T_1-1/4IN_I_PA	10328537	21	1.25"	--	130.0	57.0	61.5	40
NST820-25T_1IN_I_PA	10328534	25	1.00"	--	154.5	57.0	61.5	40
NST820-25T_1-1/4IN_I_PA	10328539	25	1.25"	--	154.5	57.0	61.5	40
NST820-25T_1-1/2IN_I_PA	10328536	25	1.50"	--	154.5	57.0	61.5	50

For steel chain series: **Rexnord**: 812 (except TAB and mini hinge), 815, 881 (except TAB), 8811 (except TAB).
single hinge straight run, single hinge Magnetflex, single hinge bevel rubber top.

For plastic chain series: 879-Bevel, 880-Bevel, 820, 831, SH, SHD, RHM, RHMD,RHMP, RHMDP, SHP.

* Ask Customer service for minimum order quantity of sprockets with inch bores.

KUS75

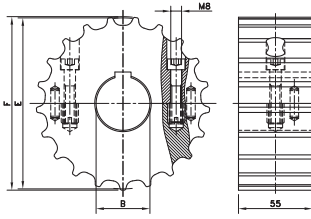

KST75

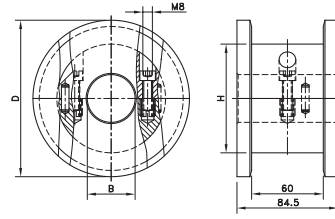

Split Sprockets And Idlers, Machined - KUS75

Sprockets, Metric Bores								
KUS75-21T_25MM_1KW_PA	10331049	21	25	129.3	130.0	55.0	55.0	-
KUS75-21T_30MM_1KW_PA	10331449	21	30					
KUS75-21T_35MM_1KW_PA	10331803	21	35					
KUS75-21T_40MM_1KW_PA	10332163	21	40					
KUS75-21T_50MM_1KW_PA	10332793	21	50					
KUS75-25T_25MM_1KW_PA	10331053	25	25	153.2	153.9	55.0	55.0	-
KUS75-25T_30MM_1KW_PA	10331453	25	30					
KUS75-25T_35MM_1KW_PA	10331807	25	35					
KUS75-25T_40MM_1KW_PA	10332167	25	40					
KUS75-25T_50MM_1KW_PA	10332797	25	50					
Idlers, Metric Bores								
KUS75-21T_25MM_I_PA	10331050	21	25	129.3	130.0	55.0	55.0	-
KUS75-21T_30MM_I_PA	10331450	21	30					
KUS75-21T_35MM_I_PA	10331804	21	35					
KUS75-21T_40MM_I_PA	10332164	21	40					
KUS75-21T_50MM_I_PA	10332794	21	50					
KUS75-25T_25MM_I_PA	10331054	25	25	153.2	153.9	55.0	55.0	-
KUS75-25T_30MM_I_PA	10331454	25	30					
KUS75-25T_35MM_I_PA	10331808	25	35					
KUS75-25T_40MM_I_PA	10332168	25	40					
KUS75-25T_50MM_I_PA	10332798	25	50					

For steel chain series: **Rexnord**: straight run heavy duty, heavy duty Magnetflex

Split Idler Drums, Machined - KST75

Metric Bores								
KST75-21T_20MM_I_PA	10330414	21	20	129.3	131.0	84.5	84.5	91
KST75-21T_25MM_I_PA	10330873	21	25					
KST75-21T_30MM_I_PA	10331276	21	30					
KST75-21T_35MM_I_PA	10331669	21	35					
KST75-21T_40MM_I_PA	10331999	21	40					
KST75-21T_50MM_I_PA	10405106	21	50	153.2	155.0	84.5	84.5	115
KST75-25T_20MM_I_PA	10330418	25	20					
KST75-25T_25MM_I_PA	10330875	25	25					
KST75-25T_30MM_I_PA	10331278	25	30					
KST75-25T_35MM_I_PA	10331671	25	35					
KST75-25T_40MM_I_PA	10332001	25	40	153.2	155.0	84.5	84.5	115
KST75-25T_50MM_I_PA	10332658	25	50					

For steel chain series: straight run heavy duty, heavy duty Magnetflex.

For plastic chain series: HDS, HDFM.

NS881

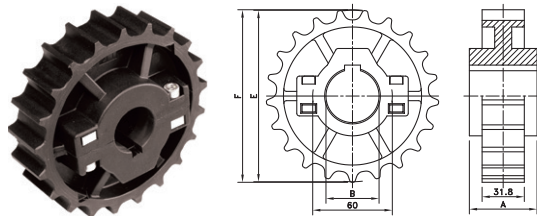

N881

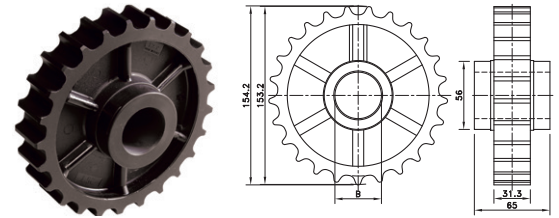

Sprocket Type	Code Number	Number of Teeth	Bore	Pitch Diameter	Outside Diameter	Width (Teeth)	Hub Width	Hub Diameter
			B	E	F	C	A	H
			mm/inch	mm	mm	mm	mm	mm

Split Sprockets and Idlers, Injection Moulded - NS881

Sprockets, Metric Bores

NS881-21T_25MM_1KW_PA	10334488	21	25	129.3	129.5	51.0	60
NS881-21T_30MM_1KW_PA	10334490	21	30				
NS881-21T_35MM_1KW_PA	10334492	21	35				
NS881-21T_40MM_1KW_PA	10334494	21	40				
NS881-21T_45MM_1KW_PA	10334496	21	45				
NS881-23T_25MM_1KW_PA	10334498	23	25	141.2	142.0	31.8	60
NS881-23T_30MM_1KW_PA	10334500	23	30				
NS881-23T_35MM_1KW_PA	10334502	23	35				
NS881-23T_40MM_1KW_PA	10334504	23	40				
NS881-23T_45MM_1KW_PA	10334506	23	45	153.2	154.2	58.5	60
NS881-25T_25MM_1KW_PA	10334507	25	25				
NS881-25T_30MM_1KW_PA	10350817	25	30				
NS881-25T_35MM_1KW_PA	10334511	25	35				
NS881-25T_40MM_1KW_PA	10334513	25	40				
NS881-25T_45MM_1KW_PA	10334515	25	45				

Sprockets, Inch Bores*

NS881-21T_1IN_1KW_PA	10328045	21	1.00"	129.3	129.5	51.0	60
NS881-21T_1-1/4IN_1KW_PA	10328307	21	1.25"				
NS881-21T_1-1/2IN_1KW_PA	10328192	21	1.50"				
NS881-23T_1IN_1KW_PA	10328046	23	1.00"	141.2	142.0	31.8	60
NS881-23T_1-1/4IN_1KW_PA	10328308	23	1.25"				
NS881-25T_1IN_1KW_PA	10328047	25	1.00"	153.2	154.2	58.5	60
NS881-25T_1-1/4IN_1KW_PA	10328310	25	1.25"				
NS881-25T_1-1/2IN_1KW_PA	10328193	25	1.50"				

Idlers, Metric Bores

NS881-21T_25MM_I_PA	10334487	21	25	129.3	129.5	51.0	60
NS881-21T_30MM_I_PA	10334489	21	30				
NS881-21T_35MM_I_PA	10334491	21	35				
NS881-21T_40MM_I_PA	10334493	21	40				
NS881-23T_25MM_I_PA	10334497	23	25	141.2	142.0	31.8	60
NS881-23T_30MM_I_PA	10334499	23	30				
NS881-23T_35MM_I_PA	10334501	23	35				
NS881-23T_40MM_I_PA	10334503	23	40				
NS881-25T_30MM_I_PA	10334508	25	30	153.2	154.2	58.5	60
NS881-25T_35MM_I_PA	10334510	25	35				
NS881-25T_40MM_I_PA	10334512	25	40				
NS881-25T_45MM_I_PA	10334514	25	45				

For steel chain series: Rexnord: 812 mini hinge, 812-TAB, 881, 8811 (all): single hinge TAB rubber top.

*Ask Customer service for minimum order quantity of sprockets with inch bores.

Classic Idlers, Injection Moulded - N881

Metric Bores

N881-25T_25MM_I_PA	10334360	25	25	153.2	154.2	31.3	65.0	56
N881-25T_30MM_I_PA	10334361	25	30					
N881-25T_35MM_I_PA	10334362	25	35					
N881-25T_40MM_I_PA	10334363	25	40					

For steel chain series: Rexnord: 812 mini hinge, 812-TAB, 881, 8811 (all).

NS821

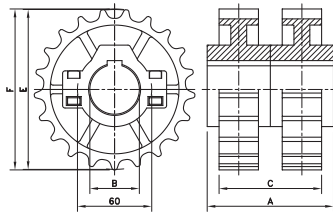

N800

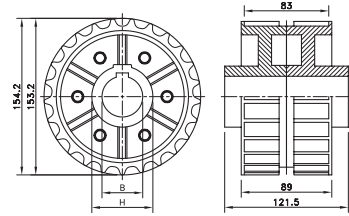

Sprocket Type	Code Number	Number of Teeth	Bore	Pitch Diameter	Outside Diameter	Width (Teeth)	Hub Width	Hub Diameter
			B	E	F	C	A	H
			mm/inch	mm	mm	mm	mm	mm

Split Sprockets And Idlers, Injection Moulded - NS821

Sprockets, Metric Bores								
NS821-21T_35MM_1KW_PA	10334434	21	35	129.2	129.5	82.0	103.0	60
NS821-21T_40MM_1KW_PA	10334436	21	40					
NS821-21T_45MM_1KW_PA	10334437	21	45					
NS821-23T_30MM_1KW_PA	10334439	23	30	141.2	142.0	82.0	103.0	
NS821-23T_35MM_1KW_PA	10334441	23	35					
NS821-23T_40MM_1KW_PA	10334443	23	40					
NS821-23T_45MM_1KW_PA	10334444	23	45	153.2	154.2	82.0	117.0	
NS821-25T_30MM_1KW_PA	10028663	25	30					
NS821-25T_35MM_1KW_PA	10334449	25	35					
NS821-25T_40MM_1KW_PA	10334451	25	40					
NS821-25T_45MM_1KW_PA	10334452	25	45					
Idlers, Metric Bores								
NS821-21T_30MM_I_PA	10334431	21	30	129.2	129.5	82.0	103.0	60
NS821-21T_35MM_I_PA	10334433	21	35					
NS821-21T_40MM_I_PA	10334435	21	40					
NS821-23T_30MM_I_PA	10334438	23	30	141.2	142.0	82.0	103.0	
NS821-23T_35MM_I_PA	10334440	23	35					
NS821-23T_40MM_I_PA	10334442	23	40					
NS821-25T_30MM_I_PA	10334446	25	30	153.2	154.2	82.0	117.0	
NS821-25T_35MM_I_PA	10334448	25	35					
NS821-25T_40MM_I_PA	10334450	25	40					

For steel chain series: Rexnord: 802 (all), 805: double hinge.
For plastic chain series: 821, SWH.

Classic Sprockets And Idlers, Injection Moulded - N800

Sprockets, Metric Bores								
N800-25T_30MM_1KW_PA	10334328	25	30	153.2	154.2	89.0	118	60
N800-25T_35MM_1KW_PA	10334329	25	35					
N800-25T_40MM_1KW_PA	10334330	25	40					
Idlers, Metric Bores								
N800-25T_30MM_I_NY	10334331	25	30	153.2	154.2	89.0	118	60
N800-25T_35MM_I_NY	10334332	25	35					
N800-25T_40MM_I_NY	10334333	25	40					

For steel chain series: Rexnord: 802 (all), 805: double hinge.

KU821

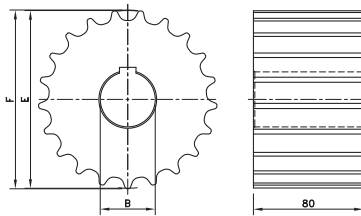

Sprocket Type	Code Number	Number of Teeth	Bore	Pitch Diameter	Outside Diameter	Width (Teeth)
			B	E	F	C
			mm/inch	mm	mm	mm

Classic Sprockets And Idlers, Machined - KU 821

Sprockets, Metric Bores						
KU821-19T_25MM_1KW_PA	10330902	19	25	117.3	116.3	80.0
KU821-19T_30MM_1KW_PA	10331305	19	30			
KU821-19T_35MM_1KW_PA	10331697	19	35			
KU821-19T_40MM_1KW_PA	10332028	19	40			
KU821-19T_50MM_1KW_PA	10332679	19	50			
KU821-21T_25MM_1KW_PA	10139159	21	25	129.3	130.0	
KU821-21T_30MM_1KW_PA	10331307	21	30			
KU821-21T_35MM_1KW_PA	10331699	21	35			
KU821-21T_40MM_1KW_PA	10332030	21	40			
KU821-21T_50MM_1KW_PA	10332681	21	50			
KU821-23T_25MM_1KW_PA	10330906	23	25	141.2	141.9	
KU821-23T_30MM_1KW_PA	10331309	23	30			
KU821-23T_35MM_1KW_PA	10331701	23	35			
KU821-23T_40MM_1KW_PA	10332032	23	40			
KU821-23T_50MM_1KW_PA	10332683	23	50			
KU821-25T_25MM_1KW_PA	10330908	25	25	153.2	153.9	
KU821-25T_30MM_1KW_PA	10331311	25	30			
KU821-25T_35MM_1KW_PA	10331703	25	35			
KU821-25T_40MM_1KW_PA	10332034	25	40			
KU821-25T_50MM_1KW_PA	10332685	25	50			
KU821-27T_25MM_1KW_PA	10330910	27	25	165.2	165.9	
KU821-27T_30MM_1KW_PA	10331313	27	30			
KU821-27T_35MM_1KW_PA	10331705	27	35			
KU821-27T_40MM_1KW_PA	10332036	27	40			
KU821-27T_50MM_1KW_PA	10332687	27	50			
KU821-29T_25MM_1KW_PA	10330912	29	25	177.2	178.0	
KU821-29T_30MM_1KW_PA	10331315	29	30			
KU821-29T_35MM_1KW_PA	10331707	29	35			
KU821-29T_40MM_1KW_PA	10332038	29	40			
KU821-29T_50MM_1KW_PA	10332689	29	50			
Idlers, Metric Bores						
KU821-19T_25MM_I_PA	10330903	19	25	117.3	116.3	80.0
KU821-19T_30MM_I_PA	10331306	19	30			
KU821-19T_35MM_I_PA	10331698	19	35			
KU821-19T_40MM_I_PA	10332029	19	40			
KU821-19T_50MM_I_PA	10332680	19	50			
KU821-21T_25MM_I_PA	10330905	21	25	129.3	130.0	
KU821-21T_30MM_I_PA	10331308	21	30			
KU821-21T_35MM_I_PA	10331700	21	35			
KU821-21T_40MM_I_PA	10332031	21	40			
KU821-21T_50MM_I_PA	10332682	21	50			
KU821-23T_25MM_I_PA	10330907	23	25	141.2	141.9	
KU821-23T_30MM_I_PA	10331310	23	30			
KU821-23T_35MM_I_PA	10331702	23	35			
KU821-23T_40MM_I_PA	10332033	23	40			
KU821-23T_50MM_I_PA	10332684	23	50			
KU821-25T_25MM_I_PA	10330909	25	25	153.2	153.9	
KU821-25T_30MM_I_PA	10331312	25	30			
KU821-25T_35MM_I_PA	10331704	25	35			
KU821-25T_40MM_I_PA	10332035	25	40			
KU821-25T_50MM_I_PA	10332686	25	50			

Sprocket Type	Code Number	Number of Teeth	Bore	Pitch Diameter	Outside Diameter	Width (Teeth)	Hub Width	Hub Diameter
			B	E	F	C	A	H
			mm/inch	mm	mm	mm	mm	mm

Classic Sprockets And Idlers, Machined - KU 821 continued

Idlers, Metric Bores								
KU821-27T_25MM_I_PA	10330911	27	25	165.2	165.9	80.0	-	-
KU821-27T_30MM_I_PA	10331314	27	30					
KU821-27T_35MM_I_PA	10331706	27	35					
KU821-27T_40MM_I_PA	10332037	27	40					
KU821-27T_50MM_I_PA	10332688	27	50					
KU821-29T_25MM_I_PA	10330913	29	25	177.2	178.0	80.0	-	-
KU821-29T_30MM_I_PA	10331316	29	30					
KU821-29T_35MM_I_PA	10331708	29	35					
KU821-29T_40MM_I_PA	10332039	29	40					
KU821-29T_50MM_I_PA	10332690	29	50					

For steel chain series: Rexnord: 802 (all), 805 double hinge For plastic chain series: 821, SWH.

KUS821

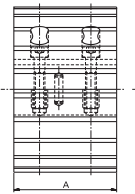
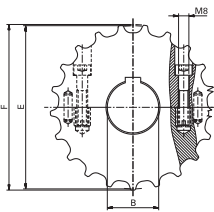

KT800

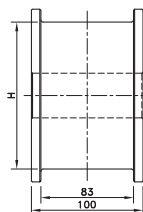
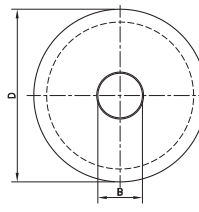

Split Sprockets And Idlers, Machined - KUS 821

Sprockets, Metric Bores								
KUS821-23T_25MM_1KW_PA	10331092	23	25	141.2	141.9	80.0	-	-
KUS821-23T_30MM_1KW_PA	10331492	23	30					
KUS821-23T_35MM_1KW_PA	10331845	23	35					
KUS821-23T_40MM_1KW_PA	10332206	23	40					
KUS821-23T_50MM_1KW_PA	10332823	23	50					
KUS821-27T_25MM_1KW_PA	10331096	27	25	165.2	165.9	80.0	-	-
KUS821-27T_30MM_1KW_PA	10331496	27	30					
KUS821-27T_35MM_1KW_PA	10331849	27	35					
KUS821-27T_40MM_1KW_PA	10332210	27	40					
KUS821-27T_50MM_1KW_PA	10332827	27	50					
Idlers, Metric Bores								
KUS821-23T_25MM_I_PA	10331093	23	25	141.2	141.9	80.0	-	-
KUS821-23T_30MM_I_PA	10331493	23	30					
KUS821-23T_35MM_I_PA	10331846	23	35					
KUS821-23T_40MM_I_PA	10332207	23	40					
KUS821-23T_50MM_I_PA	10332824	23	50					
KUS821-27T_25MM_I_PA	10331097	27	25	165.2	165.9	80.0	-	-
KUS821-27T_30MM_I_PA	10331497	27	30					
KUS821-27T_35MM_I_PA	10331850	27	35					
KUS821-27T_40MM_I_PA	10332211	27	40					
KUS821-27T_50MM_I_PA	10332828	27	50					

For steel chain series: Rexnord: 802 (all), 805 double hinge.

For plastic chain series: 821, SWH.

Classic Idler Drums, Machined - KT800

Metric Bores								
KT800-21T_25MM_I_PA	10298158	21	25*	106.8	129.8	100.0	-	106.8
KT800-23T_25MM_I_PA	10298159	23	25*	119.3	142.3			119.3
KT800-25T_25MM_I_PA	10298160	25	25*	131.7	154.7			131.7

* Pre-bore.

For steel chain series: Rexnord: 802 (all), 805 double hinge.

ST512

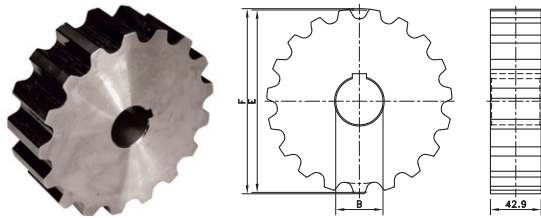

KUSMINI

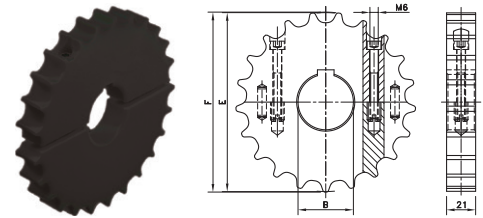

Sprocket Type	Code Number	Number of Teeth	Bore	Pitch Diameter	Outside Diameter	Width (Teeth)	Hub Width
			B	E	F	C	A
			mm/inch	mm	mm	mm	mm

Classic Sprockets, Machined - ST512

Metric Bores							
ST512-13T_20MM_I	10359896	13	20*	106.1	107.4	42.9	42.9
ST512-15T_20MM_I	10297090	15	20*	122.2	123.9		
ST512-17T_20MM_I	10297091	17	20*	138.2	140.3		
ST512-19T_20MM_I	10297092	19	20*	154.3	156.6		
ST512-21T_20MM_I	10297093	21	20*	170.4	172.9		
ST512-23T_20MM_I	10297094	23	20*	186.5	189.2		
ST512-25T_20MM_I	10330827	25	20*	202.7	205.4		

* Pre-bore

For steel chain series: **Rexnord:** 512, 581 M.

Split Sprockets, Machined - KUSMINI

Metric Bores							
KUSMINI-21T_25MM_1KW_PA	10331184	21	25	129.3	130.0	21.0	21.0
KUSMINI-21T_30MM_1KW_PA	10331584	21	30				
KUSMINI-21T_35MM_1KW_PA	10331923	21	35				
KUSMINI-21T_40MM_1KW_PA	10332297	21	40				
KUSMINI-21T_50MM_1KW_PA	10332899	21	50				
KUSMINI-25T_25MM_1KW_PA	10331188	25	25	153.2	153.9	21.0	21.0
KUSMINI-25T_30MM_1KW_PA	10331588	25	30				
KUSMINI-25T_35MM_1KW_PA	10331927	25	35				
KUSMINI-25T_40MM_1KW_PA	10332301	25	40				
KUSMINI-25T_50MM_1KW_PA	10332903	25	50				

For steel chain series: **Rexnord:** 812-narrow, mini hinge.

KUS661

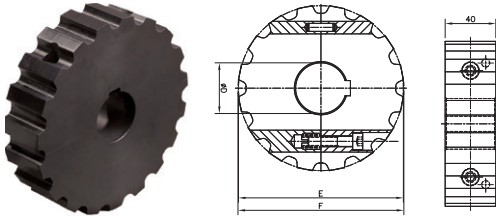

Sprocket Type	Code Number	Number of Teeth	Bore	Pitch Diameter	Outside Diameter	Hub Width
			B	E	F/D	A
			mm/inch	mm	mm	mm

Split Sprockets And Idlers, Machined - KUS661

Sprockets, Metric Bores

KUS661-11T_30MM_1KW_PA	10331464	11	30	90.2	89.9	40
KUS661-11T_35MM_1KW_PA	10331817	11	35			
KUS661-11T_40MM_1KW_PA	10332178	11	40			
KUS661-13T_30MM_1KW_PA	10331466	13	30	106.1	106.7	
KUS661-13T_35MM_1KW_PA	10331819	13	35			
KUS661-13T_40MM_1KW_PA	10332180	13	40			
KUS661-14T_30MM_1KW_PA	10331468	14	30	114.1	114.6	
KUS661-14T_35MM_1KW_PA	10331821	14	35			
KUS661-14T_40MM_1KW_PA	10332182	14	40			
KUS661-15T_30MM_1KW_PA	10331470	15	30	122.2	122.8	
KUS661-15T_35MM_1KW_PA	10331823	15	35			
KUS661-15T_40MM_1KW_PA	10332184	15	40			
KUS661-16T_30MM_1KW_PA	10331472	16	30	130.2	131.0	
KUS661-16T_35MM_1KW_PA	10331825	16	35			
KUS661-16T_40MM_1KW_PA	10332186	16	40			
KUS661-19T_30MM_1KW_PA	10331474	19	30	154.3	155.4	
KUS661-19T_35MM_1KW_PA	10331827	19	35			
KUS661-19T_40MM_1KW_PA	10332188	19	40			

Sprockets, inch bores

KUS661-11T_1-1/4IN_1KW_PA	10327201	11	1.250"	90.2	89.9	40
KUS661-11T_1-7/16IN_1KW_PA	10327677	11	1.438"			
KUS661-11T_1-1/2IN_1KW_PA	10327014	11	1.500"			
KUS661-13T_1-1/4IN_1KW_PA	10327202	13	1.250"	106.1	106.7	
KUS661-13T_1-7/16IN_1KW_PA	10327678	13	1.438"			
KUS661-13T_1-1/2IN_1KW_PA	10327012	13	1.500"			
KUS661-14T_1-1/4IN_1KW_PA	10327203	14	1.250"	114.1	114.6	
KUS661-14T_1-7/16IN_1KW_PA	10327679	14	1.438"			
KUS661-14T_1-1/2IN_1KW_PA	10327010	14	1.500"			
KUS661-15T_1-1/4IN_1KW_PA	10327204	15	1.250"	122.2	122.8	
KUS661-15T_1-7/16IN_1KW_PA	10327680	15	1.438"			
KUS661-15T_1-1/2IN_1KW_PA	10327008	15	1.500"			
KUS661-16T_1-1/4IN_1KW_PA	10327205	16	1.250"	130.2	131.0	
KUS661-16T_1-7/16IN_1KW_PA	10327681	16	1.438"			
KUS661-16T_1-1/2IN_1KW_PA	10327006	16	1.500"			
KUS661-19T_1-1/4IN_1KW_PA	10327206	19	1.250"	154.3	155.4	
KUS661-19T_1-7/16IN_1KW_PA	10327682	19	1.438"			
KUS661-19T_1-1/2IN_1KW_PA	10327004	19	1.500"			

Idlers, Metric Bores

KUS661-11T_30MM_I_PA	10331465	11	30	90.2	89.9	40
KUS661-11T_35MM_I_PA	10331818	11	35			
KUS661-11T_40MM_I_PA	10332179	11	40			
KUS661-13T_30MM_I_PA	10331467	13	30	106.1	106.7	
KUS661-13T_35MM_I_PA	10331820	13	35			
KUS661-13T_40MM_I_PA	10332181	13	40			
KUS661-14T_30MM_I_PA	10331469	14	30	114.1	114.6	
KUS661-14T_35MM_I_PA	10331822	14	35			
KUS661-14T_40MM_I_PA	10332183	14	40			
KUS661-15T_30MM_I_PA	10331471	15	30	122.2	122.8	
KUS661-15T_35MM_I_PA	10331824	15	35			
KUS661-15T_40MM_I_PA	10332185	15	40			
KUS661-16T_30MM_I_PA	10331473	16	30	130.2	131.0	
KUS661-16T_35MM_I_PA	10331826	16	35			
KUS661-16T_40MM_I_PA	10332187	16	40			
KUS661-19T_30MM_I_PA	10331475	19	30	154.3	155.4	
KUS661-19T_35MM_I_PA	10331828	19	35			
KUS661-19T_40MM_I_PA	10332189	19	40			

For steel chain series: 661.

Sprocket Type	Code Number	Number of Teeth	Bore	Pitch Diameter	Outside Diameter	Hub Width
			B	E	F/D	A
			mm/inch	mm	mm	mm

Split Sprockets And Idlers, Machined - KUS661 continued

Idlers, Inch Bores						
KUS661-11T_1-1/4IN_I_PA	10327296	11	1.250"	90.2	89.9	40
KUS661-11T_1-7/16IN_I_PA	10327772	11	1.438"			
KUS661-11T_1-1/2IN_I_PA	10327015	11	1.500"			
KUS661-13T_1-1/4IN_I_PA	10327295	13	1.250"	106.1	106.7	
KUS661-13T_1-7/16IN_I_PA	10327771	13	1.438"			
KUS661-13T_1-1/2IN_I_PA	10327013	13	1.500"			
KUS661-14T_1-1/4IN_I_PA	10327294	14	1.250"	114.1	114.6	
KUS661-14T_1-7/16IN_I_PA	10327770	14	1.438"			
KUS661-14T_1-1/2IN_I_PA	10327011	14	1.500"			
KUS661-15T_1-1/4IN_I_PA	10327293	15	1.250"	122.2	122.8	
KUS661-15T_1-7/16IN_I_PA	10327769	15	1.438"			
KUS661-15T_1-1/2IN_I_PA	10327009	15	1.500"			
KUS661-16T_1-1/4IN_I_PA	10327292	16	1.250"	130.2	131.0	
KUS661-16T_1-7/16IN_I_PA	10327768	16	1.438"			
KUS661-16T_1-1/2IN_I_PA	10327007	16	1.500"			
KUS661-19T_1-1/4IN_I_PA	10327291	19	1.250"	154.3	155.4	
KUS661-19T_1-7/16IN_I_PA	10327767	19	1.438"			
KUS661-19T_1-1/2IN_I_PA	10327005	19	1.500"			

NS831

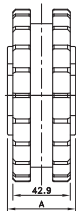
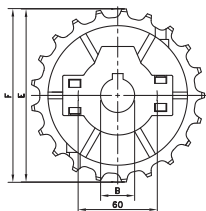

NSH820/831

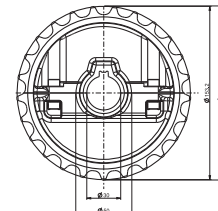

Sprocket Type	Code Number	Number of Teeth	Bore	Pitch Diameter	Outside Diameter	Width (Teeth)	Hub Width	Hub Diameter
			B	E	F	C	A	
			mm/inch	mm	mm	mm	mm	

Split Sprockets, Injection Moulded - NS831

Metric Bores								
NS831-21T_25MM_1KW_PA	10334453	21	25	129.3	129.5	51.0	60	
NS831-21T_30MM_1KW_PA	10334454	21	30					
NS831-21T_35MM_1KW_PA	10334455	21	35					
NS831-21T_40MM_1KW_PA	10334456	21	40					
NS831-21T_45MM_1KW_PA	10334457	21	45					
NS831-23T_25MM_1KW_PA	10334458	23	25	141.2	142.0	42.9		
NS831-23T_30MM_1KW_PA	10334459	23	30					
NS831-23T_35MM_1KW_PA	10334460	23	35					
NS831-23T_40MM_1KW_PA	10334461	23	40					
NS831-23T_45MM_1KW_PA	10334462	23	45	153.2	154.2	58.5		
NS831-25T_25MM_1KW_PA	10334463	25	25					
NS831-25T_30MM_1KW_PA	10334464	25	30					
NS831-25T_35MM_1KW_PA	10334465	25	35					
NS831-25T_40MM_1KW_PA	10334466	25	40					
NS831-25T_45MM_1KW_PA	10334467	25	45					
Inch Bores								
NS831-21T_1IN_1KW_PA	10328041	21	1.000"	129.26	129.5	42.9	51.0	60
NS831-25T_1IN_1KW_PA	10328042	25	1.000"	153.21	154.2	42.9	58.5	

For plastic chain series: 820, 831, SH.

* Ask Customer service for minimum order quantity of sprockets with inch bores.

Split Sprockets, Injection Moulded - NSH820/831

Metric Bores								
NSH820-25T_25MM_1KW_PA	10334525	25	25	153.2	154.2	42.9	40	60
NSH820-25T_30MM_1KW_PA	10334526	25	30					
NSH820-25T_35MM_1KW_PA	10334527	25	35					
NSH820-25T_40MM_1KW_PA	10334528	25	40					
NSH820-25T_45MM_1KW_PA	10334529	25	45					

For plastic chain series: 820, 831, SH.

KUS820

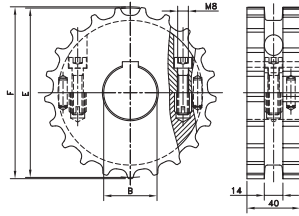

Sprocket Type	Code Number	Number of Teeth	Bore	Pitch Diameter	Outside Diameter	Width (Teeth)	Hub Width
			B mm/inch	E mm	F mm	C mm	A mm

Split Sprockets, Machined - KUS820

Metric Bores							
KUS820-17T_25MM_1KW_PA	10328705	17	25	105.5	104.5	40	40
KUS820-17T_30MM_1KW_PA	10328707	17	30				
KUS820-17T_35MM_1KW_PA	10328709	17	35				
KUS820-17T_40MM_1KW_PA	10328711	17	40				
KUS820-19T_25MM_1KW_PA	10328695	19	25	117.3	116.3		
KUS820-19T_30MM_1KW_PA	10328697	19	30				
KUS820-19T_35MM_1KW_PA	10328699	19	35				
KUS820-19T_40MM_1KW_PA	10328701	19	40				
KUS820-19T_50MM_1KW_PA	10360073	19	50	129.3	130.0		
KUS820-21T_25MM_1KW_PA	10328683	21	25				
KUS820-21T_30MM_1KW_PA	10328685	21	30				
KUS820-21T_35MM_1KW_PA	10328687	21	35				
KUS820-21T_40MM_1KW_PA	10328689	21	40	141.2	141.9		
KUS820-21T_50MM_1KW_PA	10328693	21	50				
KUS820-23T_25MM_1KW_PA	10328671	23	25				
KUS820-23T_30MM_1KW_PA	10328673	23	30				
KUS820-23T_35MM_1KW_PA	10328675	23	35	153.2	153.9		
KUS820-23T_40MM_1KW_PA	10328677	23	40				
KUS820-23T_50MM_1KW_PA	10328681	23	50				
KUS820-25T_25MM_1KW_PA	10328659	25	25				
KUS820-25T_30MM_1KW_PA	10139250	25	30	165.2	165.9		
KUS820-25T_35MM_1KW_PA	10328663	25	35				
KUS820-25T_40MM_1KW_PA	10328665	25	40				
KUS820-25T_50MM_1KW_PA	10328669	25	50				
KUS820-27T_25MM_1KW_PA	10328647	27	25	177.8	177.8		
KUS820-27T_30MM_1KW_PA	10328649	27	30				
KUS820-27T_35MM_1KW_PA	10328651	27	35				
KUS820-27T_40MM_1KW_PA	10328653	27	40				
KUS820-27T_50MM_1KW_PA	10328657	27	50				
Inch Bores							
KUS820-21T_1IN_1KW_PA	10326583	21	1.000"	129.3	130.0	40	40
KUS820-21T_1-3/16IN_1KW_PA	10327588	21	1.188"				
KUS820-21T_1-1/4IN_1KW_PA	10327270	21	1.250"				
KUS820-21T_1-7/16IN_1KW_PA	10327746	21	1.438"				
KUS815-21T_1-1/2IN_1KW_PA	10327054	21	1.500"				
KUS820-25T_1IN_1KW_PA	10326579	25	1.000"	153.2	153.9		
KUS820-25T_1-3/16IN_1KW_PA	10327590	25	1.188"				
KUS820-25T_1-1/4IN_1KW_PA	10327272	25	1.250"				
KUS820-25T_1-7/16IN_1KW_PA	10327748	25	1.438"				
KUS820-25T_1-1/2IN_1KW_PA	10326920	25	1.500"				

For plastic chain series: 820, 831, SH.

NSH880

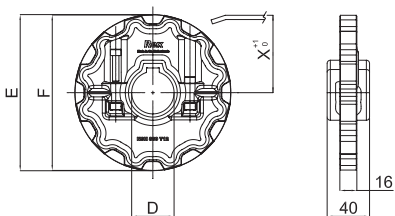

KST880

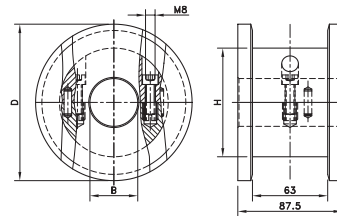

Sprocket Type	Code Number	Number of Teeth	Bore	Pitch Diameter	Outside Diameter	Width (Teeth)	Hub Width	Hub Diameter
			B	E	F	C	A	H
			mm/inch	mm	mm	mm	mm	mm

Split Sprockets Injection Moulded - NSH 880

Sprockets, Metric Bores

NSH880-12T_40MM_1KW_PA	10330171	12	40	147.2	147.4	15.9	58.5	60
------------------------	----------	----	----	-------	-------	------	------	----

Sprockets, Inch Bores

NSH880-12T_1-1/2IN_1KW_PA	10298203	12	1.5"	147.2	147.4	15.9	58.5	60
---------------------------	----------	----	------	-------	-------	------	------	----

For plastic chain series: 879, 880, RHM, RHMD, RHMP, RHMDP, SHP

Split Idler Drums, Machined - KST880

Metric Bores

Code Number	Number of Teeth	Bore	Pitch Diameter	Outside Diameter	Width (Teeth)	Hub Width	Hub Diameter
KST880-10T_25MM_I_PA	10	25	123.3	131.0	87.5	87.5	--
KST880-10T_30MM_I_PA	10	30					
KST880-10T_35MM_I_PA	10	35					
KST880-10T_40MM_I_PA	10	40					
KST880-10T_50MM_I_PA	10	50	135.2	143.0	87.5	87.5	--
KST880-11T_25MM_I_PA	11	25					
KST880-11T_30MM_I_PA	11	30					
KST880-11T_35MM_I_PA	11	35					
KST880-11T_40MM_I_PA	11	40	147.2	155.0	87.5	87.5	--
KST880-11T_50MM_I_PA	11	50					
KST880-12T_25MM_I_PA	12	25					
KST880-12T_30MM_I_PA	12	30					
KST880-12T_35MM_I_PA	12	35	147.2	155.0	87.5	87.5	--
KST880-12T_40MM_I_PA	12	40					
KST880-12T_50MM_I_PA	12	50					

For plastic chain series: 879-TAB, 880-TAB.

KUS882

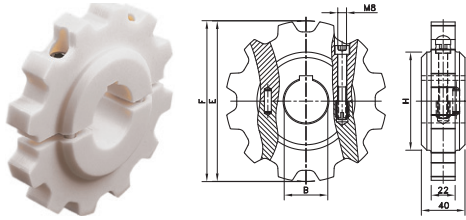

NS882

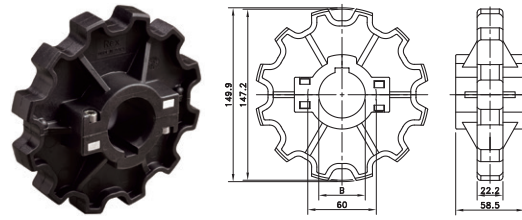

Sprocket Type	Code Number	Number of Teeth	Bore	Pitch Diameter	Outside Diameter	Width (Teeth)	Hub Width	Hub Diameter
			B	E	F	C	A	H
			mm/inch	mm	mm	mm	mm	mm

Split Sprockets And Idlers, Machined - KUS882

Sprockets, Metric Bores								
KUS882-12T_40MM_1KW_PA	10360092	12	40	147.2	147.6	22.0	40	90
KUS882-12T_50MM_1KW_PA	10360093	12	50					

Sprockets, Inch Bores								
KUS882-11T_1IN_1KW_PA	10392938	11	1.000"	135.2	135.4	22.0	40	90
KUS882-11T_1-3/16IN_1KW_PA	10392936	11	1.188"					
KUS882-11T_1-1/4IN_1KW_PA	10392935	11	1.250"					
KUS882-11T_1-7/16IN_1KW_PA	10392937	11	1.438"					
KUS882-11T_1-1/2IN_1KW_PA	10392934	11	1.500"	147.2	147.6	22.0	40	90
KUS882-12T_1IN_1KW_PA	10381624	12	1.000"					
KUS882-12T_1-3/16IN_1KW_PA	10392947	12	1.188"					
KUS882-12T_1-1/4IN_1KW_PA	10139252	12	1.250"					
KUS882-12T_1-7/16IN_1KW_PA	10392948	12	1.438"					
KUS882-12T_1-1/2IN_1KW_PA	10360094	12	1.500"					

Idlers, Metric Bores								
KUS882-11T_25MM_I_PA	10328632	11	25	135.2	135.4	22.0	40	90
KUS882-11T_30MM_I_PA	10328633	11	30					
KUS882-11T_35MM_I_PA	10328634	11	35					
KUS882-11T_40MM_I_PA	10328635	11	40					
KUS882-12T_25MM_I_PA	10328627	12	25	147.2	147.6	22.0	40	90
KUS882-12T_30MM_I_PA	10328628	12	30					
KUS882-12T_35MM_I_PA	10328629	12	35					
KUS882-12T_40MM_I_PA	10328630	12	40					
KUS882-12T_50MM_I_PA	10360077	12	50					

For plastic chain series: 882, 883, HDF, HDFM, HDS

Split Sprockets and Idlers, Injection Moulded - NS882

Sprockets, Metric Bores								
NS882-12T_25MM_1KW_PA	10028754	12	25	147.2	149.9	22.2	58.5	60
NS882-12T_30MM_1KW_PA	10019783	12	30					
NS882-12T_35MM_1KW_PA	10334518	12	35					
NS882-12T_40MM_1KW_PA	10334519	12	40					
NS882-12T_45MM_1KW_PA	10334520	12	45					

Sprockets, Inch Bores*								
NS882-12T_1IN_1KW_PA	10448021	12	1.000"	147.2	149.9	22.2	58.5	60
NS882-12T_1-1/4IN_1KW_PA	10328311	12	1.250"					
NS882-12T_1-1/2IN_1KW_PA	10328194	12	1.500"					

Idlers, Metric Bores								
NS882-12T_25MM_I_PA	10334521	12	25	147.2	149.9	22.2	58.5	60
NS882-12T_30MM_I_PA	10334522	12	30					
NS882-12T_35MM_I_PA	10334523	12	35					
NS882-12T_40MM_I_PA	10334524	12	40					

For plastic chain series: 882, 883, HDF, HDFM, HDS.

* Ask Customer service for minimum order quantity of NS882 sprockets with inch bores.

KUS880

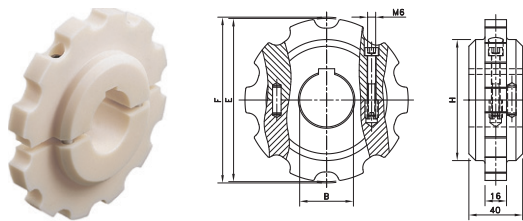

NS880

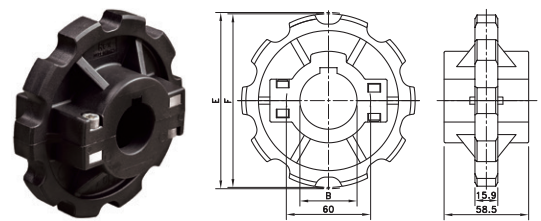

Sprocket Type	Code Number	Number of Teeth	Bore	Pitch Diameter	Outside Diameter	Width (Teeth)	Hub Width	Hub Diameter
			B	E	F	C	A	H
			mm/inch	mm	mm	mm	mm	mm

Split Sprockets And Idlers, Machined - KUS880

Sprockets, Metric Bores

KUS880-9T_25MM_1KW_PA	10328746	9	25	111.4	109.0	16.0	40.0	75				
KUS880-9T_30MM_1KW_PA	10328748	9	30									
KUS880-9T_35MM_1KW_PA	10328750	9	35									
KUS880-9T_40MM_1KW_PA	10328752	9	40	123.3	121.4			16.0	40.0	90		
KUS880-10T_25MM_1KW_PA	10328734	10	25									
KUS880-10T_30MM_1KW_PA	10328736	10	30									
KUS880-10T_35MM_1KW_PA	10328738	10	35	135.2	133.9					16.0	40.0	90
KUS880-11T_25MM_1KW_PA	10328723	11	25									
KUS880-11T_30MM_1KW_PA	10139246	11	30									
KUS880-11T_35MM_1KW_PA	10328727	11	35	147.2	145.8	16.0	40.0					90
KUS880-11T_40MM_1KW_PA	10328729	11	40									
KUS880-12T_25MM_1KW_PA	10328712	12	25									
KUS880-12T_30MM_1KW_PA	10139247	12	30	147.2	145.8			16.0	40.0			90
KUS880-12T_35MM_1KW_PA	10139248	12	35									
KUS880-12T_40MM_1KW_PA	10328718	12	40									

Idlers, Metric Bores

KUS880-9T_25MM_I_PA	10328747	9	25	111.4	109.0	16.0	40.0	75				
KUS880-9T_30MM_I_PA	10328749	9	30									
KUS880-9T_35MM_I_PA	10328751	9	35									
KUS880-9T_40MM_I_PA	10328753	9	40	123.3	121.4			16.0	40.0	90		
KUS880-10T_25MM_I_PA	10324458	10	25									
KUS880-10T_30MM_I_PA	10328737	10	30									
KUS880-10T_35MM_I_PA	10328739	10	35	135.2	133.9					16.0	40.0	90
KUS880-10T_40MM_I_PA	10328741	10	40									
KUS880-11T_25MM_I_PA	10328724	11	25									
KUS880-11T_30MM_I_PA	10328726	11	30	147.2	145.8	16.0	40.0					90
KUS880-11T_35MM_I_PA	10328728	11	35									
KUS880-11T_40MM_I_PA	10328730	11	40									
KUS880-12T_25MM_I_PA	10328713	12	25	147.2	145.8			16.0	40.0			90
KUS880-12T_30MM_I_PA	10328715	12	30									
KUS880-12T_35MM_I_PA	10328717	12	35									
KUS880-12T_40MM_I_PA	10328719	12	40									

For plastic chain series: 879, 880, RHM, RHMD, RHMP, RHMDP, SHP

Split Sprockets and Idlers, Injection Moulded - NS880

Sprockets, Metric Bores

NS880-10T_25MM_1KW_PA	10177499	10	25	123.3	122.5	15.9	58.5	60		
NS880-10T_30MM_1KW_PA	10177500	10	30							
NS880-10T_35MM_1KW_PA	10299859	10	35							
NS880-10T_40MM_1KW_PA	10177501	10	40							
NS880-10T_45MM_1KW_PA	10334477	10	45							
NS880-12T_25MM_1KW_PA	10334479	12	25	147.2	147.4			15.9	58.5	60
NS880-12T_30MM_1KW_PA	10028733	12	30							
NS880-12T_35MM_1KW_PA	10028734	12	35							
NS880-12T_40MM_1KW_PA	10334485	12	40							
NS880-12T_45MM_1KW_PA	10334486	12	45							

Sprockets, Inch Bores

NS880-12T_1IN_1KW_PA	10447311	12	1.000"	147.2	147.4	15.9	58.5	60
NS880-12T_1-1/4IN_1KW_PA	10328306	12	1.250"					

Idlers, Metric Bores

NS880-10T_25MM_I_PA	10177502	10	25	123.3	122.5	15.9	58.5	60		
NS880-10T_30MM_I_PA	10334471	10	30							
NS880-10T_35MM_I_PA	10334473	10	35							
NS880-10T_40MM_I_PA	10334475	10	40							
NS880-12T_25MM_I_PA	10334478	12	25							
NS880-12T_30MM_I_PA	10334480	12	30	147.2	147.4			15.9	58.5	60
NS880-12T_35MM_I_PA	10334482	12	35							
NS880-12T_40MM_I_PA	10334484	12	40							

For plastic chain series: 879, 880, RHM, RHMD, RHMP, RHMDP, SHP.

* Ask Customer service for minimum order quantity of NS880 sprockets with inch bores.

N1108

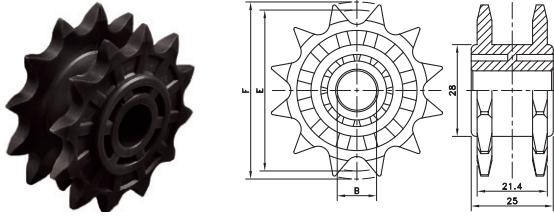

Sprocket Type	Code Number	Number of Teeth	Bore	Pitch Diameter	Outside Diameter	Width (Teeth)	Hub Width	Hub Diameter
			B	E	F	C	A	H
			mm/inch	mm	mm	mm	mm	mm

Classic Sprocket and Idler, Injection Moulded - N1108

Sprocket, Metric Bore								
N1108-12T_12MM_1KW_PA	10295382	12	12	49.1	54.0	21.4	25.0	28.0
Idler, Metric Bore								
N1108-12T_12MM_I_PA	10334286	12	12	49.1	54.0	21.4	25.0	28.0

For plastic chain series: 1108.

The drive sprocket is fixed by mounting a pin radially through sprocket and shaft.
1108 plastic chains also run on standard 1/2" pitch roller chain sprockets that meet ANSI 40.

NS1050

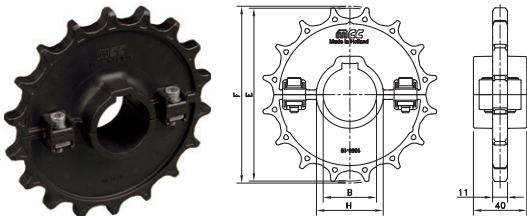

Sprocket Type	Code Number	Number of Teeth	Bore	Pitch Diameter	Outside Diameter	Width (Teeth)	Hub Width	Hub Diameter
			B	E	F	C	A	H
			mm/inch	mm	mm	mm	mm	mm

Split Sprockets and Idlers, Injection Moulded - NS1050

Sprockets, Metric Bores								
NS1050-16T_30MM_1KW_PA	10292804	16	30	130.2	130.9	11.0	40.0	40.0
NS1050-16T_40MM_1KW_PA	10139080	16	40	130.2	130.9	11.0	40.0	50.0
NS1050-18T_30MM_1KW_PA	10139079	18	30	146.3	146.8	11.0	40.0	40.0
NS1050-18T_40MM_1KW_PA	10139081	18	40	146.3	146.8	11.0	40.0	50.0
Sprockets, Inch Bores								
NS1050-16T_1-1/2IN_1KW_PA	10328181	16	1.500"	130.2	130.9	11.0	40.0	48.1
NS1050-18T_1-1/2IN_1KW_PA	10139082	18	1.500"	146.3	146.8	11.0	40.0	48.1
Idlers, Metric Bores								
NS1050-16T_30MM_I_PA	10334381	16	30	130.2	130.9	11.0	40.0	40.0
NS1050-16T_40MM_I_PA	10139078	16	40	130.2	130.9	11.0	40.0	50.0
NS1050-18T_30MM_I_PA	10139077	18	30	146.3	146.8	11.0	40.0	40.0
NS1050-18T_40MM_I_PA	10334387	18	40	146.3	146.8	11.0	40.0	50.0
Idlers, Inch Bores								
NS1050-16T_1-1/2IN_I_PA	10328180	16	1.500"	130.2	130.9	11.0	40.0	48.1
NS1050-18T_1-1/2IN_I_PA	10328182	18	1.500"	146.3	146.8	11.0	40.0	48.1

For plastic chain series: 1040, 1050, 1055, 1060.

Corner Discs for TableTop Chains

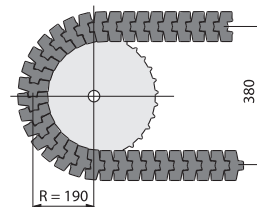
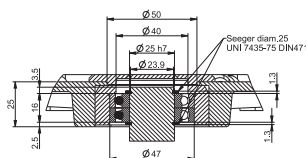
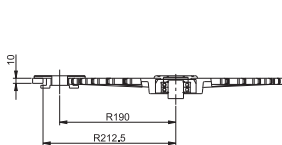

Corner Disc Type	Code Number	Execution	Open / Closed	Pitch Diameter Chain	Outside Diameter F	Weight
				mm	mm	kg

For Plastic Slatband Tab Chains 879BO, 880BO, 880BO F, HFP880BOT and LBP879BO

With 32 Teeth

N880BO-32T_50MM_PA	10365273	drive	open	380	352	0.98
--------------------	----------	-------	------	-----	-----	------

- clamping device not included (bore 50H7 mm)

With 32 Teeth

N880BO-32T_25MM_I_PA	10365292	carry/return	closed	380	352	0.98
----------------------	----------	--------------	--------	-----	-----	------

- inclusive 2x single race ball bearing 25x47x8
- contour symmetrical: no difference between carry and return corner disc
- opened by breaking out diaphragm

Without Teeth

NT880BO_I_PA	10365259	carry/return	closed	380	335	0.98
--------------	----------	--------------	--------	-----	-----	------

- inclusive 2x single race ball bearing 25x47x8.
- contour symmetrical: no difference between carry and return corner disc.
- opened by breaking out diaphragm.

Il programma del prodotto offre un'ampia gamma di catene multiflex Rexnord e catene trasporto casse MCC. Queste catene sono studiate per la movimentazione dei prodotti a singola via in numerose applicazioni.

Caratteristiche

Catene Multiflex

Queste catene utilizzano uno speciale pivot per connettere il perno della cerniera con la maglia. Nelle catene curvilinee standard il perno e la cerniera devono tenere conto della rotazione orizzontale, dovuta alla flessione della catena in curva, e della rotazione verticale durante l'avvolgimento sulla ruota. Il pivot svincola questi movimenti, in quanto il perno cerniera viene solo coinvolto durante l'avvolgimento sulla ruota. Il pivot può ruotare all'interno della maglia consentendo la flessione in curva. Grazie al pivot le catene multiflex sono ideali per applicazioni con curve multiple.

Armor Clad

Le catene multiflex 1700 sono disponibili anche con un rivestimento di acciaio indurito, l'Armor Clad AC 1700 K. Grazie a questo rivestimento, la catena è particolarmente adatta al trasporto di componenti ad elevata temperatura i quali potrebbero danneggiare una catena con superficie in plastica. Il rivestimento di acciaio conferisce alle catene un'ottima resistenza e le rende idonee per la movimentazione dei componenti nel settore automobilistico e in applicazioni simili.

Sicurezza

Le catene multiflex ZeroGap 1765 e 2565 hanno una struttura delle piastre superiori brevettata. La superficie della catena resta sempre chiusa anche quando essa avanza al di sopra di una curva o una ruota di traino. Entrambe le catene sono comunemente usate nell'industria degli imballaggi e automobilistica. Le catene multiflex 1710 K offrono inoltre delle superfici che evitano l'intrappolamento delle dita degli operatori nel caso in cui si renda necessario il trasporto di prodotti di dimensioni maggiori.

Catene trasporto casse

Queste catene hanno una struttura molto robusta, che le rende ideali per le applicazioni pesanti, come ad esempio la movimentazione di casse e cassette. Sono molto aperte in modo da non provocare problemi con i residui abrasivi che si formano in questo tipo di applicazioni. La struttura del trasportatore per queste catene può essere molto semplice, offrendo una soluzione molto economica per le notevoli distanze che spesso le cassette vuote o le casse piene devono percorrere in una linea di produzione.

Struttura a perni

Sia le catene Multiflex che le catene trasporto casse hanno delle maglie a forcina. I perni hanno una speciale struttura per impedire l'apertura delle maglie. Questo consente di effettuare carichi di lavoro elevati.

Ruote di curvatura

Per le catene multiflex e alcune catene a tapparella in acciaio curvilinee, le ruote di curvatura possono essere utilizzate per ridurre l'attrito nelle curve, consentendo l'impiego di più curve all'interno di un unico trasportatore. L'uso delle ruote di curvatura avviene principalmente nei trasportatori con movimentazione di componenti a bassa velocità nelle applicazioni per l'industria casearia, automobilistica, del tabacco, ecc...

La ruota di curvatura N880 con profilo dentato è utilizzata per trainare la catena e dispone di ruota di traino e funzione di curvatura nella ruota di curvatura. Ciò significa che per la catena non è necessaria nessuna sezione di ritorno, rendendo la struttura del trasportatore più semplice ed economica. In questo tipo di trasportatore, tuttavia, l'entità dell'allungamento del passo dovuta all'usura e che può essere assorbita è limitata. Il disco è montato sugli alberi di azionamento mediante un dispositivo di bloccaggio per il quale possono essere utilizzati i componenti standard della macchina. Il disco di trasporto viene utilizzato nella parte superiore del trasportatore, entrando in contatto con la catena nella posizione normale durante il trasporto dei prodotti. Il disco di ritorno viene utilizzato nella parte di ritorno del trasportatore, entrando in contatto con la catena nella posizione rovesciata.

Le ruote di curvatura munite di cuscinetti a sfera sono consigliate per le applicazioni ad alta velocità e per carichi elevati; i cuscinetti a sfera non sono inclusi.

In tutte le altre applicazioni, possono essere utilizzate ruote di curva tura con cuscinetti in termoplastica.

Il disco in versione aperta consente il passaggio dell'albero. In cima all'albero viene utilizzato il disco in versione chiusa. Alcune versioni chiuse, come la 880BO, offrono la possibilità di rompere un diaframma nel tappo di chiusura.



Programma

Le catene Multiflex e le catene trasporto casse sono disponibili nelle seguenti versioni:

Rexnord Multiflex Chains	
1765	Catena con passo da 50 mm ZeroGap senza aree aperte sia in curva che durante l'avvolgimento sulla ruota; bassa rumorosità e lunga durata
2565	Catena ZeroGap con passo da 76 mm senza spazi nella versione rettilinea; versione per carichi pesanti in poliamide resistente all'usura
1757	Catena con passo da 1,5" con struttura unica delle piastre superiori, ideale per i trasportatori modulari di alluminio estrusi, comunemente usati nelle applicazioni per la movimentazione dei componenti; disponibile anche con superficie gommata
1700	Catena standard con passo da 50 mm in caso di utilizzo di ruote di curvatura; disponibile in 3 versioni: standard, con alette e con superficie superiore in acciaio indurito (AC1700K)
1720	Catena con passo da 50 mm per contenitori in cartone irregolari; bidirezionale e con bordi regolari
1775	1775 Zerogap 25 mm pitch chain with unique zerogap plate design, ideal for critical product handling like delicate consumer packaging
1785	1785 Zerogap designed with a heavy-duty 2-inch (48 mm) pitch. This chain can be used in a variety of industrial applications.
Case Conveyor Chains	
CC 600	Standard chain; available in straight running and sideflexing executions
CC 631	Standard chain with higher links; available in sideflexing execution; can be supplied with pusher
CC 1400	Reinforced chain; available in straight running and sideflexing executions
CC 1431	Reinforced chain with higher links; available in sideflexing execution
BSM2755	The 2755 Series Chain is designed for heavy load side-flex applications which require a combination of high-strength and robustness

Applicazione

Chain Type	Standard Stable Products	Small Parts & Unstable Products	Large & Heavy Products (industrial)	Wide Products	Bi-directional Conveyors	Abrasive Parts Conveying	Inline Conveyors	Crate Conveying	Finger Safety
1700	Best choice					Optional		Optional	
AC 1700						Best choice			
1757	Optional	Best choice		Optional			Best choice		
1765 ZeroGap™	Optional	Best choice			Best choice	Optional			Best choice
1775 ZeroGap™	Optional	Best choice							Best choice
1785 ZeroGap™	Optional	Best choice	Best choice	Best choice		Optional			Best choice
2565 ZeroGap™			Best choice	Optional	Best choice	Optional			Best choice
CC 600/631/1400/1431			Optional					Optional	
BSM2755			Best choice	Optional		Best choice		Best choice	

Optional Best choice

1765 ZeroGap™

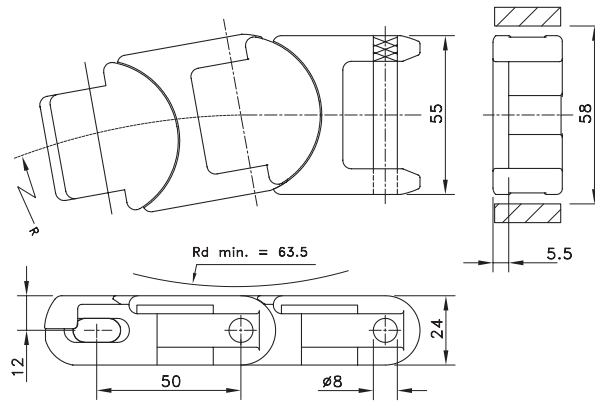
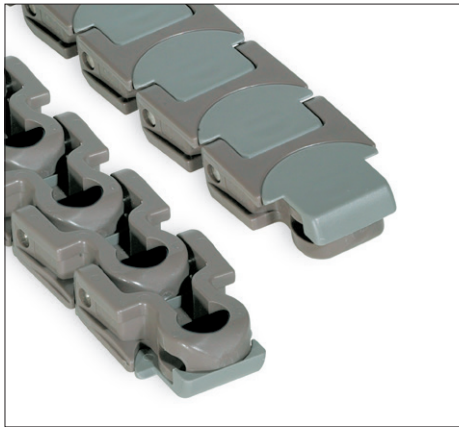

Chain Type	Code Number	Link Width		Weight kg/m	Working Load (max.) N (21°C)	Backflex Radius (min) mm	Sideflex Radius (min) mm
		mm	inch				
HP-Acetal							
HP1765 ZG-55MM	10177518	55.0	2.17	1.46	2670	63.5	125
BWX-Polyamide Composite							
BWX1765 ZG-55MM	10373979	55.0	2.17	1.46	2670	63.5	125

Standard length: 3.05 m - 10 feet (61 links).

1775 ZeroGap™

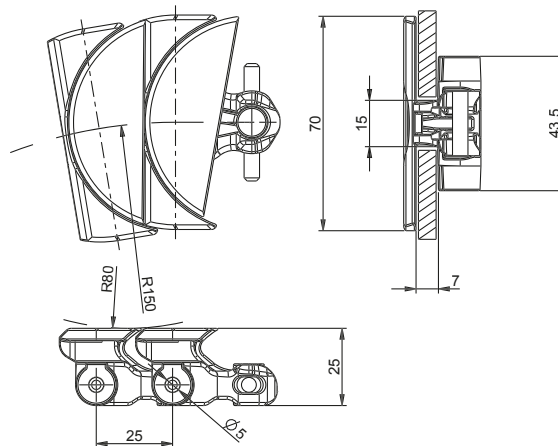
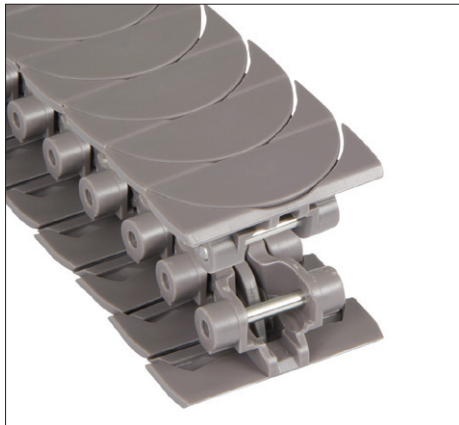

Chain Type	Code Number	Link Width		Weight kg/m	Working Load (max.) N (21°C)	Backflex Radius (min) mm	Sideflex Radius (min) mm
		mm	inch				
HP-Acetal							
HP1775 ZG-70MM	10177523	70.0	2.76	1.05	1000	80	150

Standard length: 5 m - 16.4 ft (200 pitches).

1785 ZeroGap™

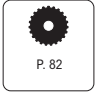
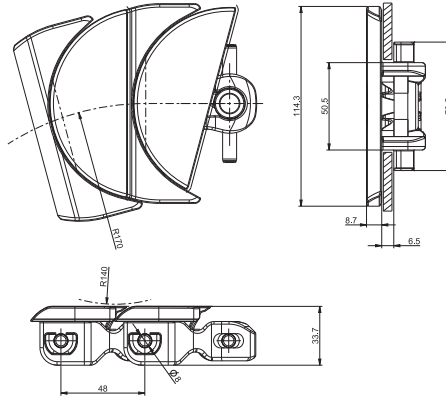
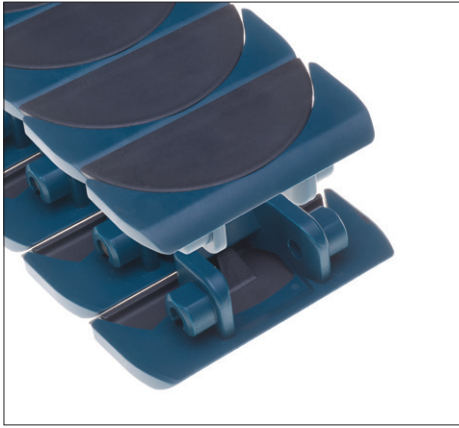

Chain Type	Code Number	Link Width		Weight kg/m	Working Load (max.) N (21°C)	Backflex Radius (min) mm	Sideflex Radius (min) mm
		mm	inch				
XLG-Acetal							
XLG1785 ZG	10186170	114.3	4.5	2.54	2500	140	170

Standard length: 2.40 m - 7.87 feet (50 links).

2565 ZeroGap™ Heavy Duty

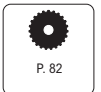
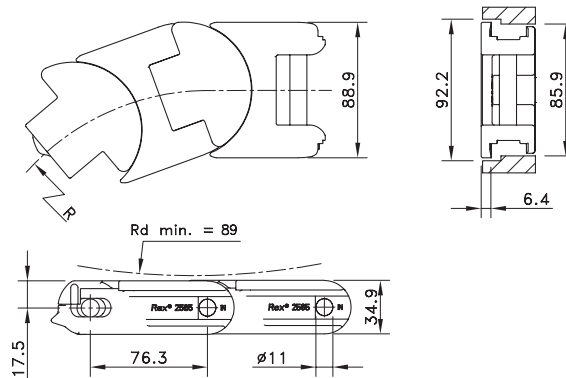

Chain Type	Code Number	Link Width		Weight kg/m	Working Load (max.) N (21°C)	Backflex Radius (min) mm	Sideflex Radius (min) mm
		mm	inch				
BWX-Polyamide							
BWX2565 ZG-3.5IN SS PINS	10145689	88.9	3.50	2.67	10675	89	241

Standard length: 3.048 m - 10 feet (40 links).

1757 TAB

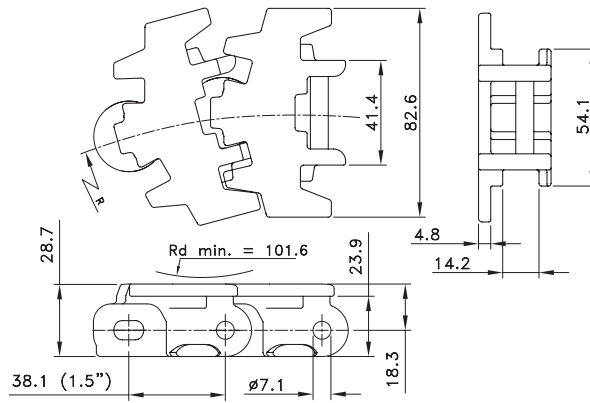
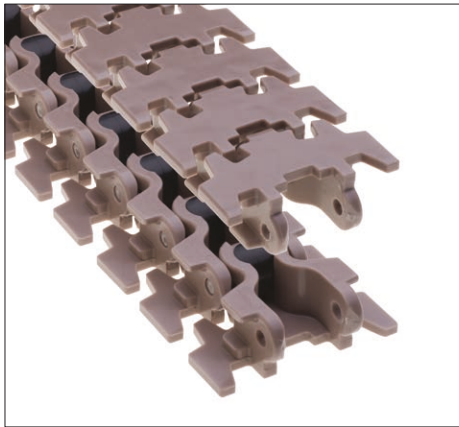

Chain Type	Code Number	Link Width		Weight	Working Load (max.)	Backflex Radius (min)	Sideflex Radius (min)
		A					
		mm	inch				
LF-Acetal							
LF1757TAB-3.25IN SS PIN	10144646	82.6	3.25	1.48	1735	102	152

Standard length: 3.048 m - 10 feet (80 links).

1757 TAB with Rubber

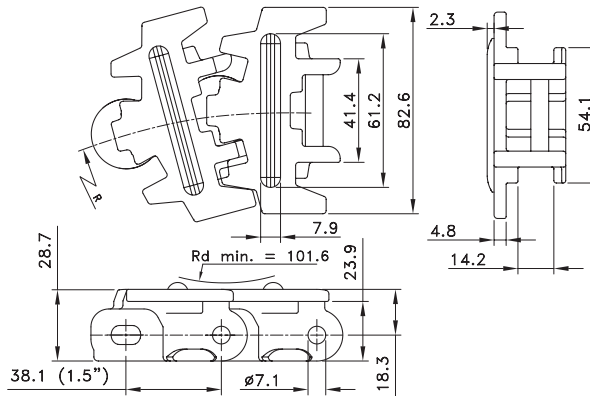
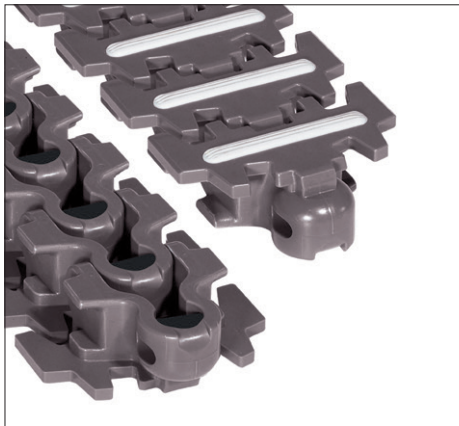

Chain Type	Code Number	Link Width		Weight	Working Load (max.)	Backflex Radius (min)	Sideflex Radius (min)
		A					
		mm	inch				
HP-Acetal							
HP1757TAB SG-3.25IN 1SGD60 T1P ZN PIN	10145209*	82.6	3.25	1.48	1735	102	152

Standard length: 3.048 m - 10 feet (80 links).

* Minimum order quantity 30.48 m – 100 feet.

1700

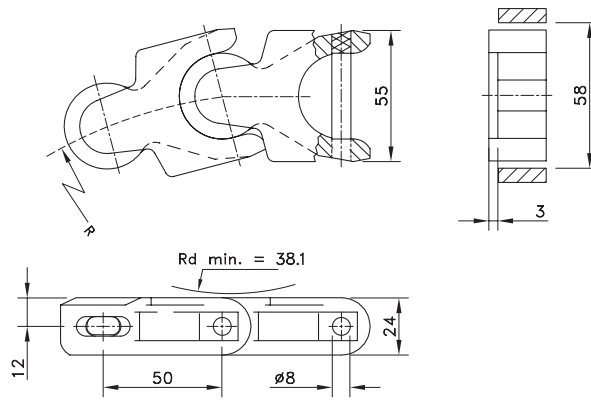
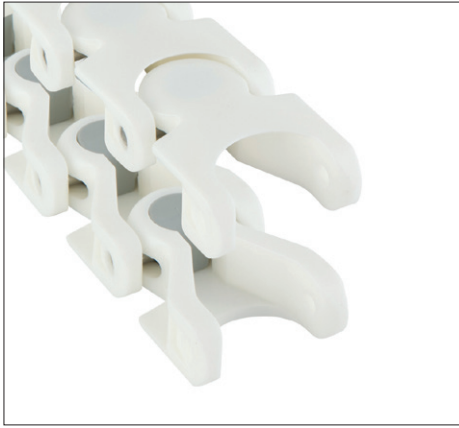

Chain Type	Code Number	Link Width A		Weight kg/m	Working Load (max.) N (21°C)	Backflex Radius (min) mm	Sideflex Radius (min) mm
		mm	inch				
LF-Acetal							
LF1700-55MM SS PIN	10156539	55.0	2.17	1.26	2670	38.1	140
WLF-Acetal							
WLF1700-55MM SS PIN	10145092	55.0	2.17	1.26	2670	38.1	140
HP-Acetal							
HP1700-55MM	10374004	55.0	2.17	1.26	2670	38.1	140
Acetal with Hardened Steel Top Plates							
LF1700K AC-ZN-55MM ZN PIN	10374002	55.0	2.17	60	2670	38.1	140

Standard length: 10 m - 32.8 feet (200 links).

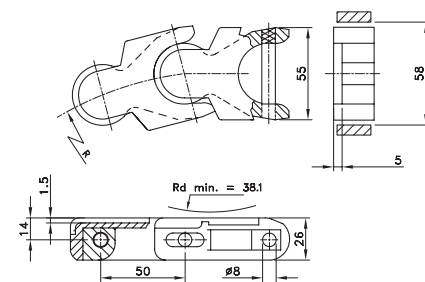

AC (Armor Clad) Execution

AC (Armor Clad) Execution

1700 TAB K

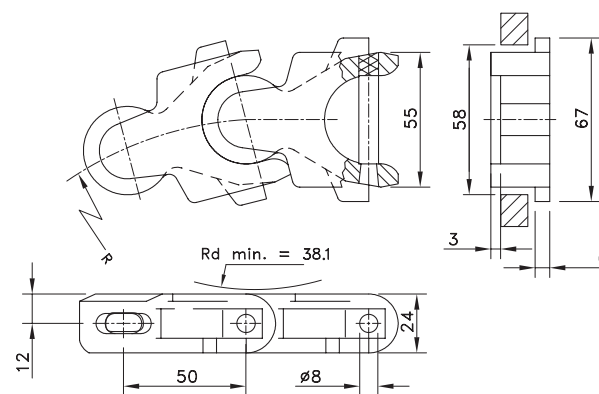

Chain Type	Code Number	Link Width A		Weight kg/m	Working Load (max.) N (21°C)	Backflex Radius (min) mm	Sideflex Radius (min) mm
		mm	inch				
WLF-Acetal							
WLF1700TAB K-55MM	10183027	55.0	2.17	1.30	2670	38.1	140

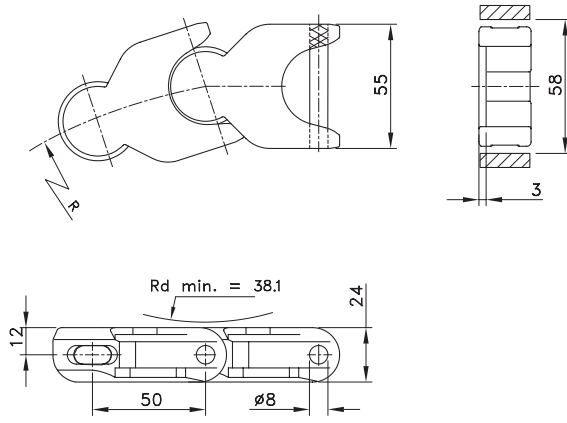

Chain Type	Code Number	Link Width		Weight	Working Load (max.)	Backflex Radius (min)	Sideflex Radius (min)
		A					
		mm	inch				
HP-Acetal							
HP1720-55MM	10373999	55.0	2.17	1.26	2600	50	140

Standard length: 10 m - 32.8 feet (200 links).

N1700

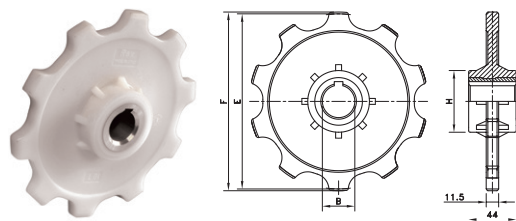

N1700

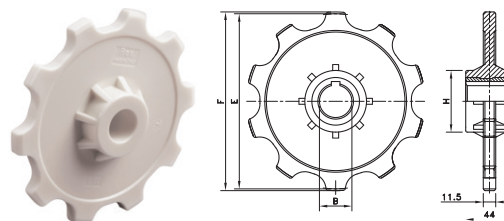

Sprocket Type	Code Number	Number of Teeth	Bore	Pitch Diameter	Outside Diameter	Width (Teeth Ring)	Hub Width	Hub Diameter
			B	E	F			
			mm	mm	mm	mm	mm	mm

N1700 - Classic Plastic Sprockets, Injection Moulded, Brass Hub

Metric Bores

N1700-10T_24MM_1KW_PA	10334287	10	24	161.8	165.1	11.1	44.0	57
N1700-10T_25MM_1KW_PA	10334289	10	25					
N1700-10T_30MM_1KW_PA	10334290	10	30					

For Multiflex chain series: 1700, 1710, 1713, 1720, 1765.

NX 1700 - Classic Plastic Idler, Injection Moulded

Metric Bores

N1700-10T_25MM_I_PA	10177513	10	25	161.8	165.1	11.1	43.0	50
---------------------	----------	----	----	-------	-------	------	------	----

For Multiflex chain series: 1700, 1713, 1720, 1765.

KU1700

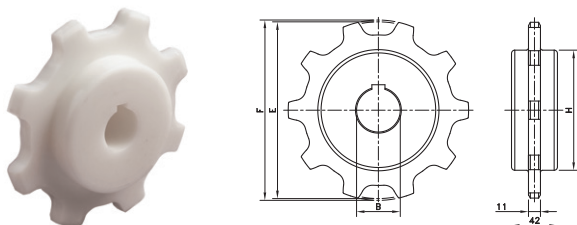

KU1775

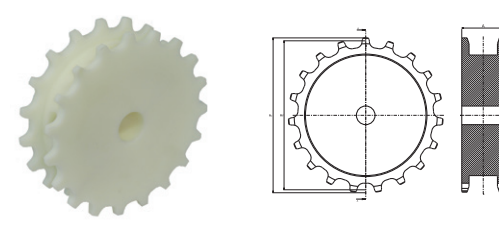

KU 1700 - Classic Plastic Sprockets, Machined

Metric Bores

KU1700-8T_20MM_P_PA	10298178	8	19	130.7	132.8	11.1	42.0	79
KU1700-8T_25MM_1KW_PA	10330978	8	25					
KU1700-8T_30MM_1KW_PA	10331380	8	30					
KU1700-10T_20MM_P_PA	10298179	10	19	161.8	165.1	11.1	42.0	110
KU1700-10T_25MM_1KW_PA	10330980	10	25					
KU1700-10T_30MM_1KW_PA	10331382	10	30					
KU1700-13T_20MM_P_PA	10298180	13	19	209.0	215.2	11.1	42.0	158

For Multiflex chain series: 1700, 1713, 1720, 1765

KU 1775 - Classic Plastic Sprockets, Machined

Metric Bores

KU1775-19T_19MM_P_PA	10283942	19	25	151.9	157.9	7.4	43.8	112.9
----------------------	----------	----	----	-------	-------	-----	------	-------

For Multiflex chain series: 1775.

ZN1700

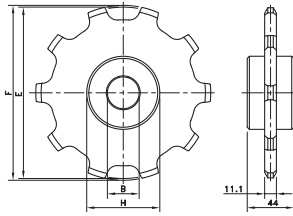

CI1757

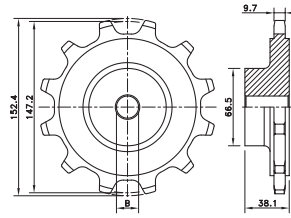

Sprocket Type	Code Number	Number of Teeth	Bore	Pitch Diameter	Outside Diameter	Width (Teeth Ring)	Hub Width	Hub Diameter H
			B	E	F			
			mm	mm	mm	mm	mm	mm

Classic Zinc Plated Steel Idlers - ZN 1700

Metric Bores

ZN1700-10T_20MM_I	10365357	10	20	161.8	165.1	11.1	44.0	69.0
ZN1700-12T_20MM_I	10365358	12	20	193.2	196.1			

For Multiflex chain series: 1700w, 1710, 1713, 1720, 1765.

Classic Semi-Steel Sprocket, Excentered Hub - CI1757

Inch Bores

CI1757-12T_3/4IN_RSB_B	10014778	12	0.750"	147.2	152.4	9.7	38.1	66.5
------------------------	----------	----	--------	-------	-------	-----	------	------

For Multiflex chain series: 1757

NT1757

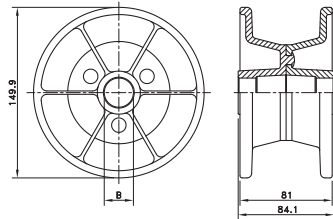

KUS2500

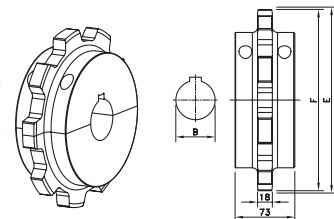
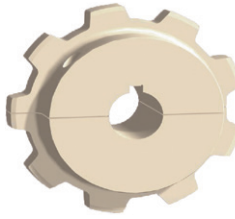

Classic Plastic Idler Drum, Injection Moulded - NT1757

Metric Bores

NT1757-10.5T_1IN_I_LF	10015525	10	25	-	149.9	81	84.1	38.1
-----------------------	----------	----	----	---	-------	----	------	------

For Multiflex chain series: 1757.

Split Plastic Sprockets, Injection Moulded - KUS2500

Metric Bores

KUS2500-9T_50MM_1KW_PA	10370621	9	50	222.8	221.2	18.0	73.0	165.0
------------------------	----------	---	----	-------	-------	------	------	-------

For Multiflex chain series: 2565.

KUS1775

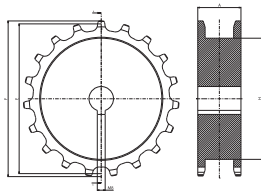

KUS1780

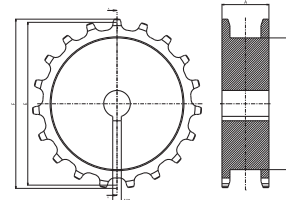

Split Plastic Sprockets, Machined - KUS1775

Metric Bores

KUS1775-19T_25MM_1KW_PA	10365398	19	25	151.9	157.9	7.4	43.8	112.9
-------------------------	----------	----	----	-------	-------	-----	------	-------

For Multiflex chain series: 1775

Split Plastic Sprockets, Machined - KUS1780

Metric Bores

KUS1780-9T_40MM_1KW1SS_PA	10365384	9	40	140.34	146	9	70	-
---------------------------	----------	---	----	--------	-----	---	----	---

For Multiflex chain series: 1785.

ND1700 B

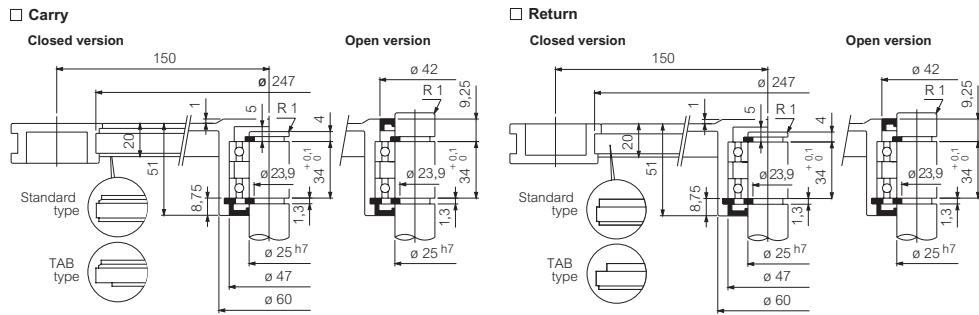

Corner Disc Type	Code Number	Execution	Open/ Closed	Outside Diameter	Weight
				mm	kg

Corner Discs including bearings For Plastic Multiflex Chains 1700 K, 1720 K and 1765 Zerogap

CORNERDISC 10IN 1700 CLOSED CARRY PA	10177515	carry	closed	247	0.70
ND1700BO-TR	10365369	carry	open		
CORNERDISC 10IN 1700 CLOSED RETURN PA	10177514	return	closed		
ND1700BO-RET	10365366	return	open		

Corner Disc including bearings For TAB Chain

CORNERDISC ASSY 1700TAB CLOSED CARRY PA	10322155	carry	closed	247	0.70
ND1700TBO-TR	10365370	carry	open		
ND1700TBC-RET	10365367	return	closed		
ND1700TBO-RET	10365368	return	open		

- prepared for 2x single race ball bearing (25x47x12 mm)

ND1700 FL

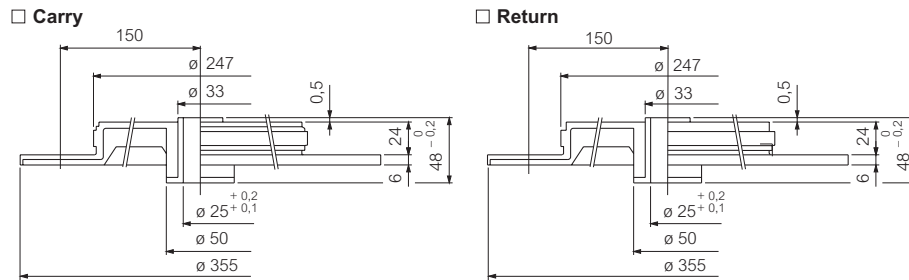
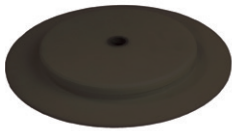

With Flanges (Ø355)

ND1700FL-TR	10365379	carry	open	247	0.92
ND1700FL-RET	10365343	return	open		

- plastic bushing diameter $\varnothing 25$ mm.

ND1755

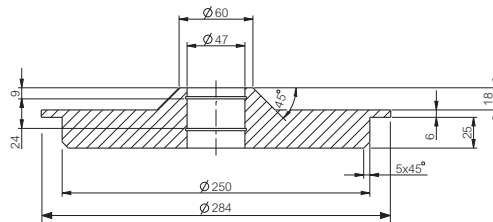

With Flanges (Ø355)

ND1755	10285932	carry	open	250	0.92
--------	----------	-------	------	-----	------

ND1700

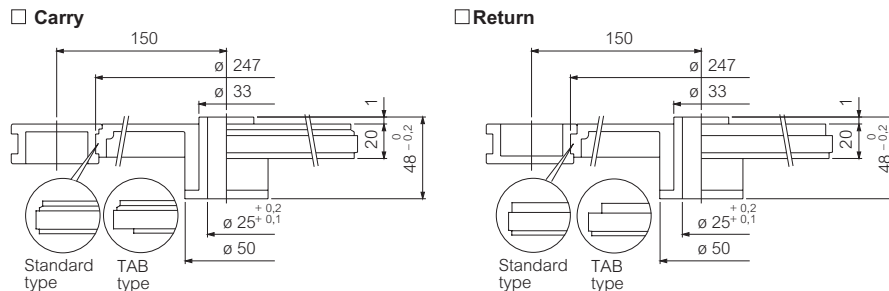

Corner Disc with Bushing (Non TAB)

ND1700T-TR	10365363	carry	open	247	0.47
ND1700-TR	10365362	return	open		

Corner Discs with Bushing TAB

ND1700T-RET	10365365	carry	open	247	0.47
ND1700-RET	10365364	return	open		

- plastic bushing diameter $\varnothing 25$ mm.

Straight Run without TABS

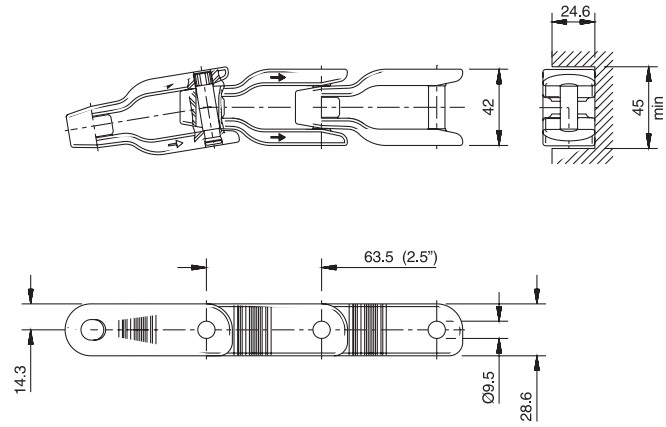
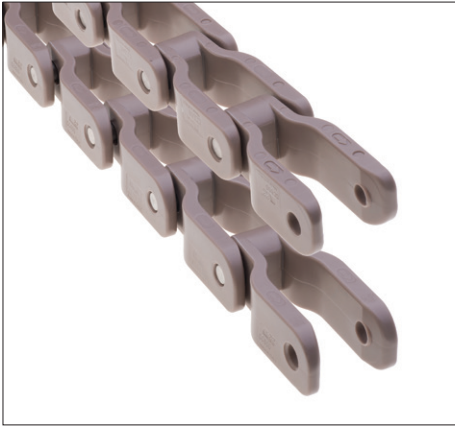

Chain Type	Code Number	Link Width A		Weight kg/m	Working Load (max.) N (21°C)	Backflex Radius (min) mm	Sideflex Radius (min) mm
		mm	inch				
LF-Acetal							
LF600-42MM	10139129	42.0	1.66	1.20	3950	50	457
NC-Acetal							
NC600-42MM	10139130	42.0	1.66	1.20	3950	50	457
WPP-Polypropylene							
WPP600-42MM	10375143*	42.0	1.66	1.00	1975	50	457

Standard length: 3.048 m - 10 feet (48 links).

*Ask customer service for minimum order quantity.

Sideflex with TABS

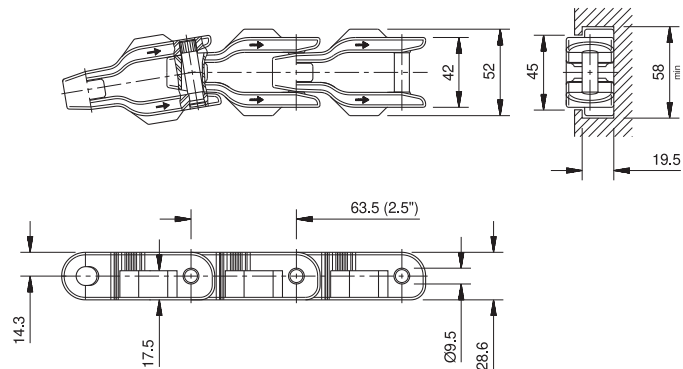

Chain Type	Code Number	Link Width A		Weight kg/m	Working Load (max.) N (21°C)	Backflex Radius (min) mm	Sideflex Radius (min) mm
		mm	inch				
LF-Acetal							
LF600TAB-42MM	10375137	42.0	1.66	1.25	3950	50	457
NC-Acetal							
NC600TAB-42MM	10375141	42.0	1.66	1.25	3950	50	457
WPP-Polypropylene							
WPP600TAB-42MM	10375142*	42.0	1.66	1.03	1975	50	457

Standard length: 3.048 m - 10 feet (48 links).

*Ask customer service for minimum order quantity.

Sideflex with Tabs with Higher Link

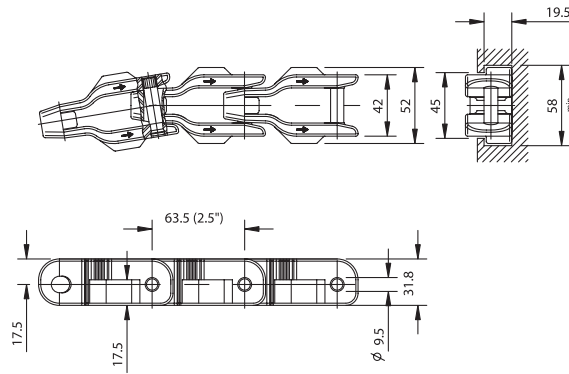

Chain Type	Code Number	Link Width A		Weight kg/m	Working Load (max.) N (21°C)	Backflex Radius (min) mm	Sideflex Radius (min) mm
		mm	inch				
LF-Acetal							
LF631TAB-42MM	10139125	42.0	1.66	1.35	3950	50	457
NC-Acetal							
NC631TAB-42MM	10375130*	42.0	1.66	1.35	3950	50	457

Standard length: 3.048 m - 10 feet (48 links).

*Ask customer service for minimum order quantity.

Straight Run Reinforced without Tabs

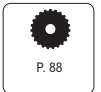
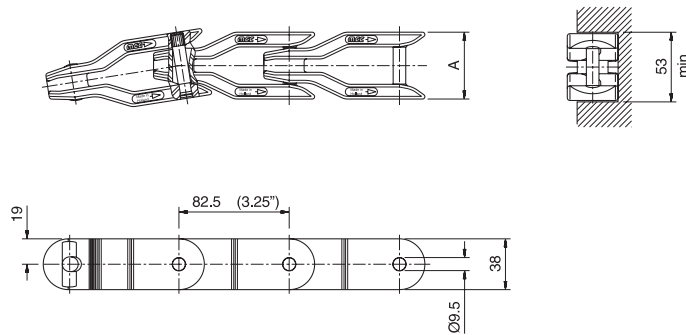

Chain Type	Code Number	Link Width A		Weight kg/m	Working Load (max.) N (21°C)	Backflex Radius (min) mm	Sideflex Radius (min) mm
		mm	inch				
LF-Acetal							
LF1400-50MM	10139124	50.0	1.97	1.70	6500	50	660
NC-Acetal							
NC1400-50MM	10375123	50.0	1.97	1.70	6500	50	660

Standard length: 3.053 m - 10 feet (37 links).

Sideflex Reinforced with TABS

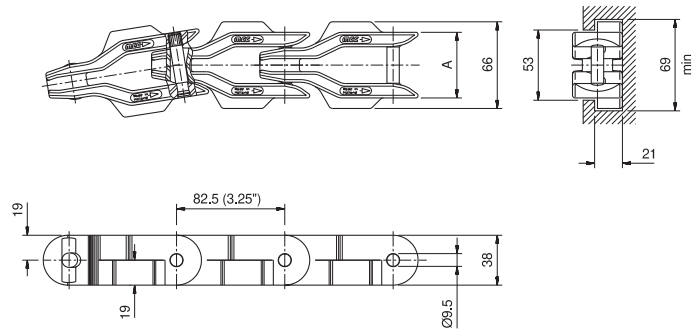

Chain Type	Code Number	Link Width A		Weight kg/m	Working Load (max.) N (21°C)	Backflex Radius (min) mm	Sideflex Radius (min) mm
		mm	inch				
LF-Acetal							
LF1400TAB-50MM	10139123	50.0	1.97	1.75	6500	50	660
NC-Acetal							
NC1400TAB-50MM	10375122	50.0	1.97	1.75	6500	50	660

Standard length: 3.053 m - 10 feet (37 links).

Sideflex Reinforced with Tabs with Higher Link

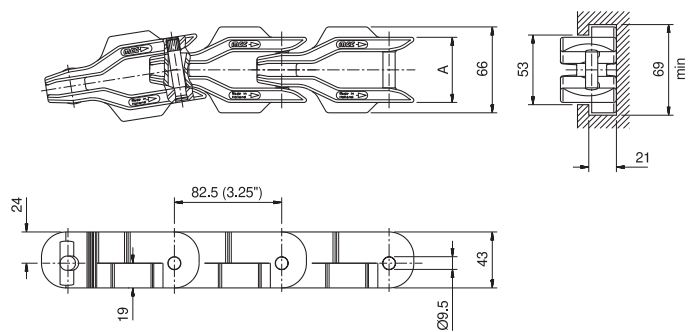

Chain Type	Code Number	Link Width A		Weight kg/m	Working Load (max.) N (21°C)	Backflex Radius (min) mm	Sideflex Radius (min) mm
		mm	inch				
LF-Acetal							
LF1431TAB-50MM	10375147	50.0	1.97	2.02	6500	50	660
NC-Acetal							
NC1431TAB-50MM	10375150	50.0	1.97	2.02	6500	50	660

Standard length: 3.053 m - 10 feet (37 links).

* Ask customer service for minimum order quantity of CC1431 TBL chains.

BSM 2755 Series TableTop Chain

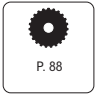
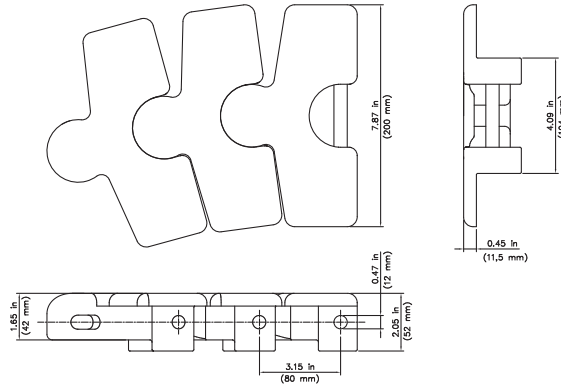

Chain Type	Code Number	Plate Width		Weight	Working Load (max.)	Sideflex Radius (min)	Backflex Radius (min)	Plate Thickness
		mm	inch					
BSM2755-200MM	10374922	200	7.87	6.1	12.500	23.9 / 600	4.9 / 125	0.45 / 11.5

Standard length: 1.52 m – 5 ft (19 links).



CC600/631

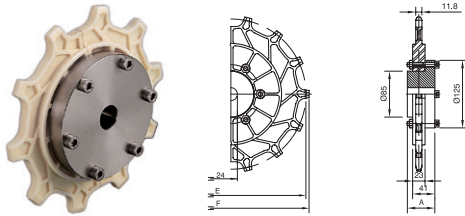

KU600

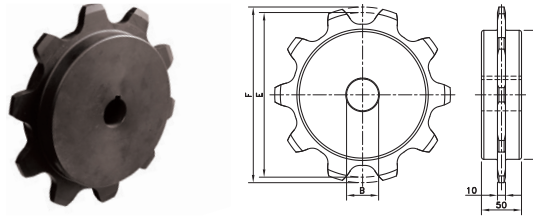

Type	Code Number	Number of Teeth	Bore B	Pitch Diameter E	Outside Diameter F	Hub Width A
			mm	mm	mm	mm

Semi-Split Sprockets for CC600/631

Sprocket Ring Set						
SPLIT SPROCKETR.SET CC600 Z=10	10359856	10	-	205.5	209.4	-
SPROCKET RING CC600-14T	10139158	14	-	285.4	289.8	-
Carbon Steel Hub						
CH CC-C 24MM_I	10359844	-	24	-	-	50
Stainless Steel Hub						
CH CC-S 24MM_I	10359843	-	24	-	-	50

The split sprocket rings and unsplit hubs are supplied separately, so that the hub doesn't need to be replaced in case of wear of the sprocket rings.

Classic Sprockets for CC600/631

Metric Bores						
KU600-6T_20MM_P_PA	10298157	6	20	127.0	128.0	50
KU600-8T_20MM_P_PA	10298154	8	20	165.9	177.7	
KU600-10T_20MM_P_PA	10298155	10	20	205.5	219.3	

CC1400/1431

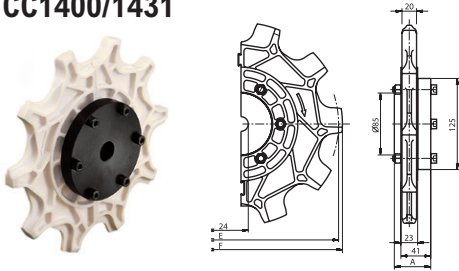

Semi-Split Sprockets for CC1400/1431						
Sprocket Ring Set						
SPROCKET RING CC1400-10T	10139157	10	-	267.0	278.4	-
Carbon Steel Hub						
CH CC-C 24MM_I	10359844	-	24	-	-	50
Stainless Steel Hub						
CH CC-S 24MM_I	10359843	-	24	-	-	50

The split sprocket rings and unsplit hubs are supplied separately, so that the hub doesn't need to be replaced in case of wear of the sprocket rings.

KU2755

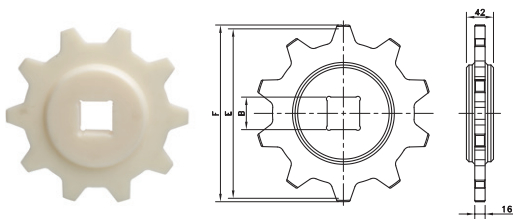

Classic Sprocket for BSM 2755						
KU2755-10T_40MM_S_PA	10401412	10	40	258.9	274	42
KU2755-10T_40MM_1KW_PA	10400243	10	40	258.9	274	42
KU2755-10T_50MM_S_PA	10360824	10	50	258.9	274	42

Rexnord fornisce un'ampia gamma di catene Plate Top e per elevatori e discensori. La catena a rulli Plate Top è stata sviluppata per fornire una maggiore capacità di carico e consente velocità più elevate e scorrimenti più lunghi rispetto alle catene a piastre. Le catene a rulli per ascensori e discensori sono perfetti per alzare, abbassare, risciacquare, sterilizzare e invertire i prodotti, grazie agli elementi elevatori e discensori in gomma morbida.

La catena di base è disponibile in acciaio o acciaio inossidabile.



Caratteristiche

Catene Plate Top

Queste catene permettono un'enorme capacità di carico, velocità più elevate, scorrimenti più lunghi con un unico sistema di traino. Le serie 843 e 1843 a corsa rettilinea offrono catene di base a rulli conformi allo standard ANSI 40. Il passo ridotto da 12,7 mm riduce l'effetto cordale e consente di utilizzare ruote di traino di dimensioni più ridotte. Sono consigliate per il posizionamento passo-passo.

La serie 1864 e 963 a corsa rettilinea offrono catene di base a rulli conformi allo standard ANSI 60. Le serie 1874, 1873 e 3873 a corsa curvilinea offrono catene di base a rulli conformi allo standard Side Bow ANSI 63 SB. Anch'esse sono ideali per il posizionamento passo-passo.

Le catene Plate Top che dispongono di piastre in acciaio sono appositamente studiate per le condizioni abrasive, lavori pesanti o alta temperatura. Le catene serie 963, 1873 e 3873 con piastre superiori in plastica "ad incastro" combinano i vantaggi di una superficie di trasporto in plastica con quelli di una catena di base a rulli di precisione: minor avanzamento a scatti, elevato carico di lavoro e posizionamento accurato; le tapparelle sostituibili sono agganciate ai perni sporgenti.

Catene per elevatori e discensori

Le applicazioni principali delle catene per elevatori tuttavia, possono essere utilizzate in numerose altre situazioni, come la movimentazione di cassette e la produzione di lattine per bevande. Le tipiche soluzioni di catene per elevatori e discensori sono degli omega per l'agevole attraversamento delle linee di produzione, con il sollevamento e l'abbassamento mediante elevatori a catena per elevatori e discensori. Gli elevatori e discensori possono essere a 2 o 3 denti per i prodotti di dimensioni ridotte e del tipo D per le altre applicazioni.

Maglie di collegamento

Tutte le catene a rulli vengono fornite in sezioni da 3 metri e dispongono di maglia di collegamento, in modo tale da poter congiungere le catene con molta facilità.

Ruote di traino

Le catene Top Plate non richiedono ruote di traino speciali. Le ruote di traino conformi agli standard ANSI 40 e 60 sono idonee e pertanto non rientrano nell'offerta standard Rexnord.

Programma

Plate Top	
1864	Catene rettilinee con tapparelle in acciaio, idonee per carichi pesanti, lunghe distanze ed alte velocità. La catena consiste in un catena a rulli di base con piastre saldate nella parte superiore in varie leghe di acciaio. La distanza tra le piastre ha un'ampiezza di 1,6 mm
963	Le catene rettilinee con tapparelle sovrapposte di plastica, pertanto, hanno un senso di lavoro unidirezionale. La superficie continua facilita la stabilità e agevola le operazioni con prodotti instabili
843	Le catene rettilinee con tapparelle sovrapposte di plastica, pertanto, sono agganciate a perni sporgenti. Senso di lavoro unidirezionale
1843 TAB	Catene ad alette curvilinee con tapparelle in plastica. Stessa struttura della serie 843
1874 TAB	Catene curvilinee con tapparelle in acciaio "ad incastro" per formare una superficie trasportatrice piana continua. Le tapparelle forniscono ritenzione positiva nelle curve e nelle inclinazioni. Vengono utilizzate nelle condizioni con particolare abrasività, lavori pesanti o elevate temperature
1873 TAB	Catene curvilinee con tapparelle in plastica; senso di lavoro bidirezionale. Disponibili anche con inserto in gomma antiscivolo per trasporto inclinato fino a 25°. Le guide TAB consentono il passaggio da trasporto inclinato a trasporto in piano e viceversa
3873 TAB	Catene curvilinee con tapparelle in plastica per superficie continua, anche con raggio ridotto. Perfette per il trasporto di vassoi. Le tapparelle in policarbonato sono estremamente resistenti agli impatti

Gripper	
1874 TAB	Dispone di tapparelle in acciaio per condizioni abrasive o alta temperatura. La base è una catena a rulli standard Side Bow ANSI 63 SB. Gli elementi elevatori e discensori sono disponibili come GD (tampone liscio) e GJ (tampone dentato). Essendo a incastro, sono facilmente sostituibili. La clip per la guida TAB è rivettato sulla tapparella. La versione per carichi pesanti può gestire carichi più elevati, determinano un aumento del 15% della forza di tensione e consente la riduzione dell'allungamento durante l'uso. La struttura per carichi pesanti delle tapparelle implica che la guida e la tapparella sono un'unità singola
1843 TAB	Munite di tapparelle in termoplastica per un funzionamento più silenzioso e senza problemi; queste catene per elevatori e discensori di dimensioni ridotte consentono la riduzione del peso dell'impianto, consentono velocità più elevate ed un funzionamento a secco. La base è una catena a rulli standard Side Bow ANSI 43 SB. Gli elementi elevatori e discensori ad incastro sono disponibili come GD (tampone liscio) e GJ (tampone dentato). Queste catene sono particolarmente indicate per il trasporto di fiale, provette ed altri prodotti di dimensioni ridotte quali i piccoli componenti industriali.
1873 TAB	Munite di tapparelle in termoplastica per un funzionamento più silenzioso e senza problemi; consentono la riduzione del peso dell'impianto, velocità più elevate ed un funzionamento a secco. La base è una catena a rulli standard Side Bow ANSI 63 SB. Le catene per elevatori e discensori GSD/GS2J/GS3J sono ad incastro, per agevolarne la sostituzione, le catene per elevatori e discensori GDB/GJB sono resistenti alla piegatura e le GJM sono integrate nella tapparella, ideali per le applicazioni di imballaggio

La descrizione della catena consiste, rispettivamente, nel materiale, nel tipo, nel numero K relativo alla larghezza in pollici e in una G per gli elevatori e i discensori e in un codice che indica la versione dell'elevatore/discensore: La D indica le catene D che forniscono un tampone liscio o una superficie piana; la J indica un tampone dentato, in alcuni casi insieme al numero denti per ciascuna maglia. Infine, la S indica un sistema di montaggio di elevatori e discensori in gomma speciali, resistente alla piegatura. La M indica un elevatore e discensore integrato, stampato nella tapparella, ideale nelle applicazioni di imballaggio.

Application

Plate Top Chain Type	Clean, dry, light duty	Clean, wet, light duty	Abrasive, dry, light duty	Abrasive, wet, light duty	Clean, dry, heavy duty	Clean, wet, heavy duty	Abrasive, dry, heavy duty	Abrasive, wet, heavy duty	Incline conveyor
1864									
1864 SS									
963									
843									
1843 TAB									
1874 TAB									
1873 TAB, LF Top Plate									
3873 TAB									
HFP 1873 TAB									

Application

Gripper Chain Type	Small empty product elevator	Small full product elevator	Large empty product elevator	Large full product elevator	Rinser application, ambient	Rinser application, high temperature
1874 TAB, Stainless Steel Top Plate						
1843 TAB, LF top plate						
1873 TAB, HP top plate						
1873 TAB, LF top plate						

Steel base chains are recommended for dry applications, stainless steel base chains are recommended for wet applications.

Optional
Best choice

Straight Run 3/4" Pitch Steel Top Plate

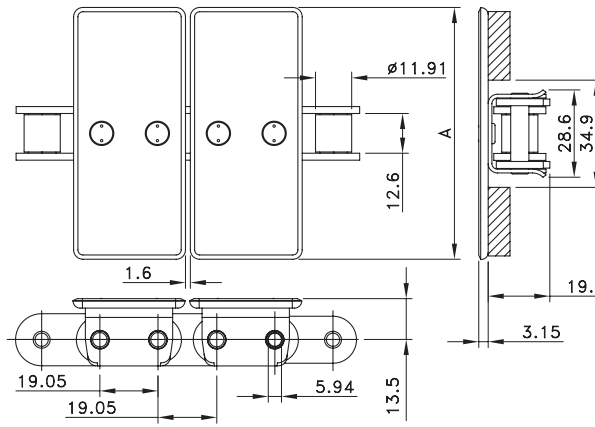
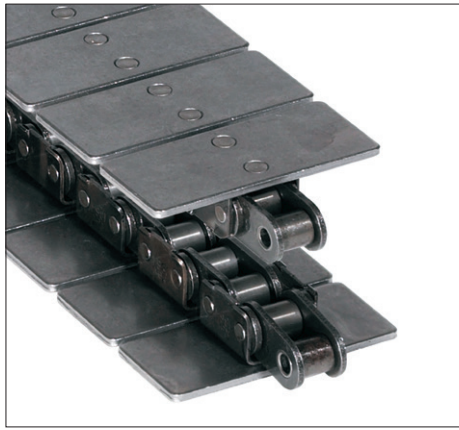

1864 MO Pin Plate
(Part #10106156)
Identifies Connector Link



1864 (SS) MO Pin Plate
(Part #10106077)
Identifies Connector Link



Chain Type	Code Number	Plate Width A		Weight kg/m	Loose Top Plate Code Number	Working Load (max.) N (21°C)	Connection Link	
		mm	inch				Type	Code Number
Steel Top Plate/Steel Base Chain								
S1864 S-3.25IN	10144787	82.5	3.25	3.33	10106067	4500	CONN LINK 1864 S	10106156
S1864 S-4.5IN	10144788	114.3	4.50	4.00	10106068			
S1864 S-6IN	10144789	152.4	6.00	4.40	10106069			
S1864 S-7.5IN	10144790	190.5	7.50	4.80	10106070			
Stainless Steel Top Plate/Stainless Steel Base Chain								
SS1864 SS-3.25IN	10144792	82.5	3.25	3.33	10106072	3400	CONN LINK 1864 SS	10106077
SS1864 SS-4.5IN	10144793	114.3	4.50	4.00	10106073			
SS1864 SS-6IN	10144794	152.4	6.00	4.40	10106074			
SS1864 SS-7.5IN	10144795	190.5	7.50	4.80	10106075			

Standard length: 3.048 m – 10 feet (160 links). Min. backflex radius 305 mm.

Straight Run 3/4" Pitch Plastic Top Plate

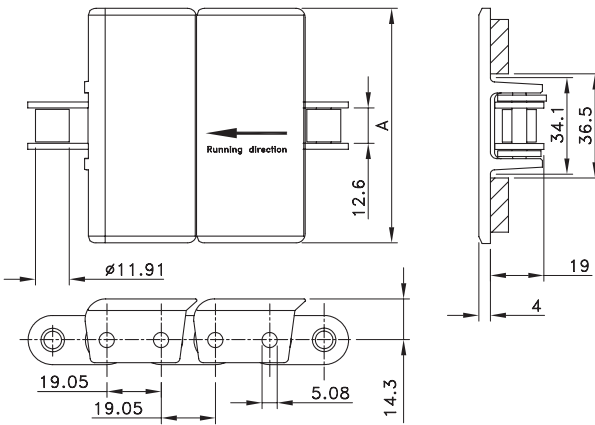
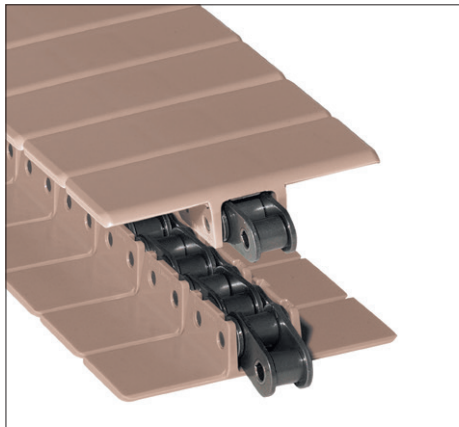

63 Pin Plate
(Part #10370501)
Identifies Connector Link



63 (SS) MO Pin Plate
(Part #10178902)
Identifies Connector Link



Chain Type	Code Number	Plate Width A		Weight kg/m	Loose Top Plate Code Number	Working Load (max.) N (21°C)	Connection Link	
		mm	inch				Type	Code Number
LF-Acetal Top Plate/Steel Base Chain								
LF963 S-3.25IN	10177766	82.5	3.25	2.10	10069778	2700	CL 63_BTL SP	10370501
LF963 S-4.5IN	10177768	114.3	4.50	2.23	10069785			
LF963 S-6IN	10177770	152.4	6.00	2.53	10069792			
LF963 S-7.5IN	10177771	190.5	7.50	2.68	10069798			
LF-Acetal Top Plate/Stainless Steel Base Chain								
LF963 SS-3.25IN	10177772	82.5	3.25	2.10	10069778	1900	CL 63 SS_KRV UKS BTL SP	10137637
LF963 SS-4.5IN	10177773	114.3	4.50	2.23	10069785			
LF963 SS-6IN	10177774	152.4	6.00	2.53	10069792			
LF963 SS-7.5IN	10177775	190.5	7.50	2.68	10069798			

Standard length: 3.048 m – 10 feet (160 links). Min. backflex radius 153 mm.

Straight Run 1/2" Pitch Plastic Top Plate

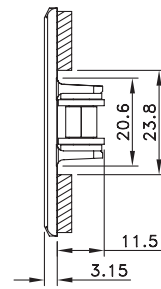
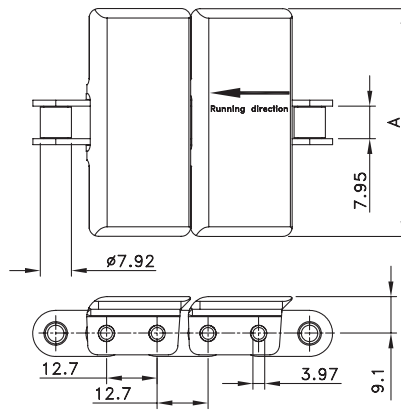
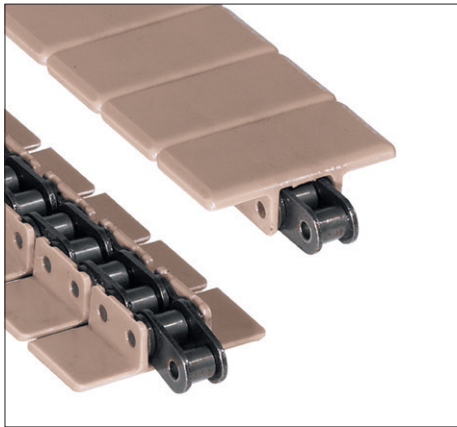

843 MO Pin Plate
(Part #10364059)
Identifies Connector Link



843 (SS) MO Pin Plate
(Part #10147845)
Identifies Connector Link



Chain Type	Code Number	Plate Width A		Weight	Loose Top Plate	Working Load (max.)	Connection Link	
		mm	inch				Type	Code Number
LF-Acetal Top Plate/Steel Base Chain								
LF843-1.38IN	10373764	34.9	1.38	0.83	10364639	2700	CONN LNK 843 S LP	10364059
LF843-1.44IN	10373765	36.5	1.44	0.84	10363789			
LF843-2IN	10373766	50.8	2.00	0.89	10364318			
LF843-3.25IN	10373767	82.5	3.25	1.03	L0843623581			
LF-Acetal Top Plate/Stainless Steel Base Chain								
LF843 SS-1.375IN	10177709	34.9	1.38	0.83	10364639	1900	CL 843 SS SP_M377 UKS BTL SP	10147845
LF843 SS-1.438IN	10177710	36.5	1.44	0.84	10363789			
LF843 SS-2IN	10177711	50.8	2.00	0.89	10364318			
LF843 SS-3.25IN	10177712	82.5	3.25	1.03	10364640			

Standard length: 3.048 m – 10 feet (240 links).
Min. backflex radius 153 mm.

Sideflex 1/2" Pitch Tab Plastic Top Plate

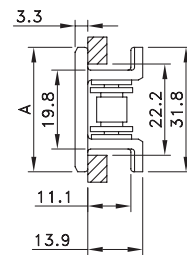
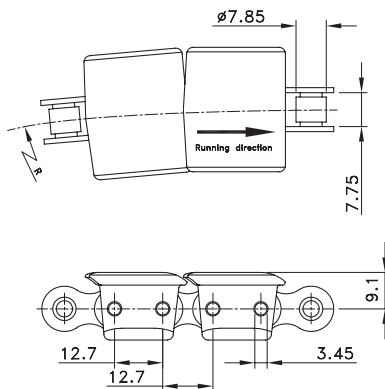
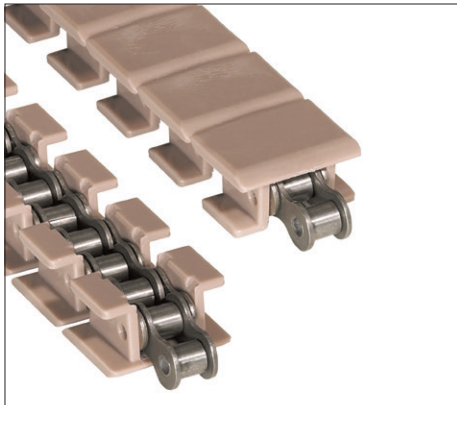

1843 MO Pin Plate
(Part #10084585)
Identifies Connector Link



Chain Type	Code Number	Plate Width A		Weight	Loose Top Plate	Working Load (max.)	Sideflex Radius (min)	Connection Link	
		mm	inch					Type	Code Number
LF-Acetal Top Plate/Steel Base Chain									
LF1843TAB S-1.25IN	10177561	31.8	1.25	0.74	10365405	2700	254	CONN LNK 1843 S	10084585
LF1843TAB S-2IN	10177562	50.8	2.00	0.90	10365406				

Standard length: 3.048 m – 10 feet (240 links).
Min. backflex radius 102 mm.

Sideflex 3/4" Pitch Tab Steel Top Plate

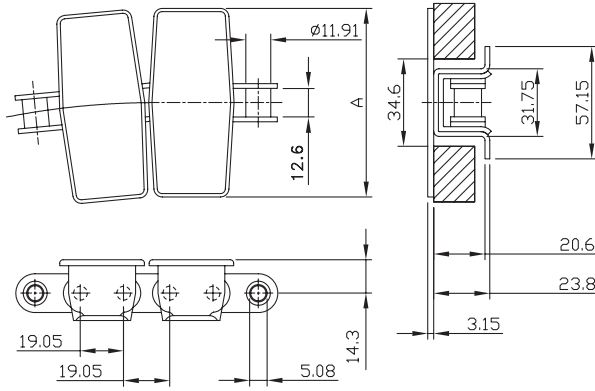
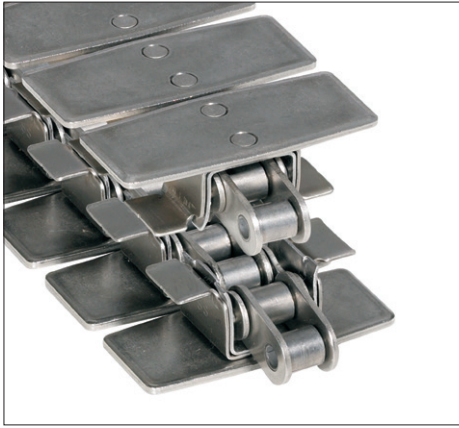

63 Pin Plate
(Part #10370501)
Identifies Connector Link



63 (SS) MO Pin Plate
(Part #10137637)
Identifies Connector Link





Chain Type	Code Number	Plate Width		Weight	Loose Top Plate	Working Load (max.)	Sideflex Radius (min)	Connection Link	
		A						Type	Code Number
		mm	inch	kg/m	Code Number	N (21°C)	mm		
Steel Top Plate/Steel Base Chain									
S1874TAB S-3.25IN	10084603	82.5	3.25	4.20	10069632	4500	381	CL 63_BTL SP	10370501
S1874TAB S-4.5IN	10084604	114.3	4.50	4.80	10069634		381		
S1874TAB S-6IN	10084605	152.4	6.00	5.70	10069638		457		
S1874TAB S-7.5IN	10084606	190.5	7.50	6.40	10069635		610		
Stainless Steel Top Plate/Stainless Steel Base Chain									
SS1874TAB SS-3.25IN	10084609	82.5	3.25	4.20	10069636	3400	381	CL 63 SS_KRV UKS BTL SP	10137637
SS1874TAB SS-4.5IN	10084610	114.3	4.50	4.80	10069637		381		
SS1874TAB SS-6IN	10084611	152.4	6.00	5.70	10069640		457		
SS1874TAB SS-7.5IN	10084612	190.5	7.50	6.40	10069639		610		

Standard length: 3.048 m – 10 feet (160 links).
Min. backflex radius 254 mm.

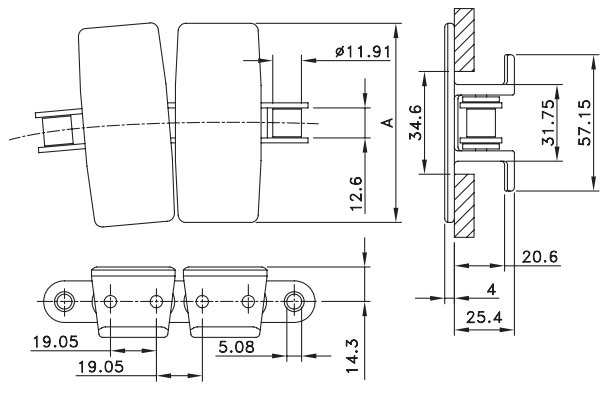
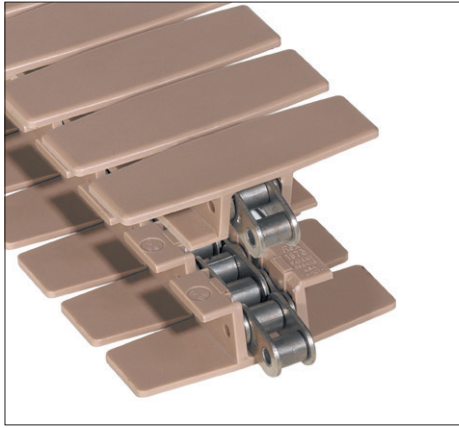
Sideflex 3/4" Pitch Tab Plastic Top Plate



63 Pin Plate
 (Part #10370501)
 Identifies Connector Link



63 (SS) MO Pin Plate
 (Part #10137637)
 Identifies Connector Link



Chain Type	Code Number	Plate Width		Weight	Loose Top Plate	Working Load (max.)	Sideflex Radius (min)	Connection Link	
		A						Type	Code Number
		mm	inch	kg/m	Code Number	N (21°C)	mm		
LF-Acetal Top Plate/Steel Base Chain									
LF1873TAB S-3.25IN	10177569	82.5	3.25	2.10	10365410	4500	390	CL 63_BTL SP	10370501
LF1873TAB S-4.5IN	10177570	114.3	4.50	2.30	10365524		457		
LF1873TAB S-6IN	10177571	152.4	6.00	2.40	10365525		610		
LF1873TAB S-7.5IN	10177572	190.5	7.50	2.60	10365523				
LF1873TAB S-10IN	10177566	254.0	10.00	2.80	10365522				
LF1873TAB S-12IN	10177567	304.8	12.00	3.00	10365526				
LF-Acetal Top Plate/Stainless Steel Base Chain									
LF1873TAB SS-3.25IN	10177576	82.5	3.25	2.10	10365410	3400	390	CL 63 SS_KRV UKS BTL SP	10137637
LF1873TAB SS-4.5IN	10177577	114.3	4.50	2.30	10365524		457		
LF1873TAB SS-6IN	10177578	152.4	6.00	2.40	10365525		610		
LF1873TAB SS-7.5IN	10177579	190.5	7.50	2.60	10365523				
LF1873TAB SS-10IN	10177573	254.0	10.00	2.80	10365522				
LF1873TAB SS-12IN	10177574	304.8	12.00	3.00	10365526				

Standard length: 3.048 m – 10 feet (160 links). Min. backflex radius 305 mm.

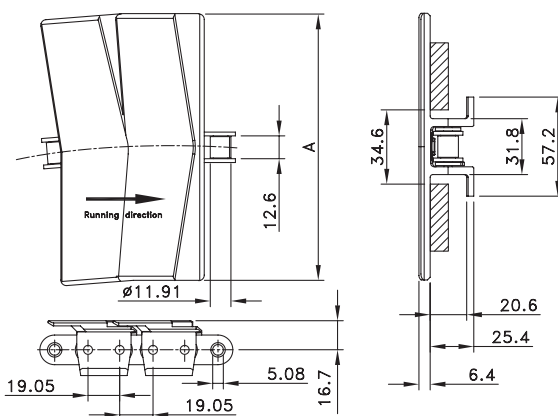
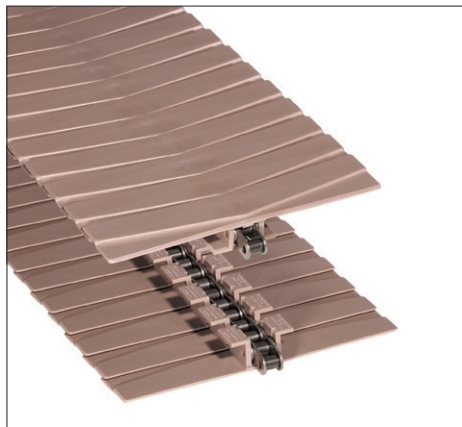
Sideflex 3/4" Pitch Tab Plastic Top Plate Closed Surface



63 (SS) MO Pin Plate
(Part #10137637)
Identifies Connector Link



Chain Type	Code Number	Plate Width A		Weight kg/m	Loose Top Plate Code Number	Working Load (max.) N (21°C)	Sideflex Radius (min) mm	Connection Link	
		mm	inch					Type	Code Number
LF-Acetal Top Plate/Stainless Steel Base Chain									
LF3873TAB SS-10IN	10177583	254.0	10.00	3.10	10069624	3400	457	CL 63 SS_KRV UKS BTL SP	10137637
PC Polycarbonate Top Plate/Stainless Steel Base Chain									
W3873TAB SS-12IN	10145876	304.8	12.00	3.20	10069220	3400	610	CL 63 SS_KRV UKS BTL SP	10137637

Standard length: 3.048 m – 10 feet (160 links).
Min. backflex radius 178 mm.

Sideflex 3/4" Pitch Tab Plastic Top Plate With Rubber

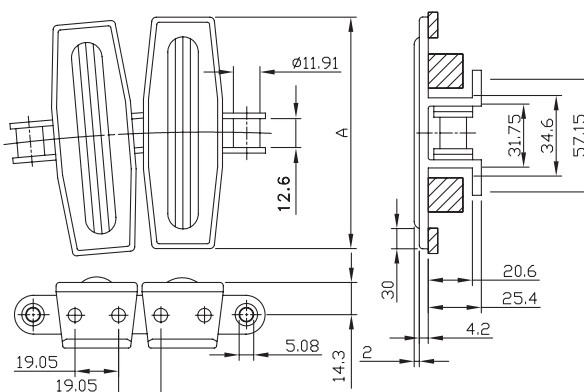

63 Pin Plate
(Part #10370501)
Identifies Connector Link



63 (SS) MO Pin Plate
(Part #10137637)
Identifies Connector Link



Chain Type	Code Number	Plate Width A		Weight kg/m	Loose Top Plate Code Number	Working Load (max.) N (21°C)	Sideflex Radius (min) mm	Connection Link	
		mm	inch					Type	Code Number
LF-Acetal Top Plate/Steel Base Chain									
LF1873TAB SG S-7.5IN 1SGD60 T1P	10177531	190.5	7.50	3.10	10177526	4500	457	CL 63_BTL SP	10370501
LF1873TAB SG-10IN D60	10373916	54.0	10.00	3.40	10177527				
LF1873TAB SG S-12IN 1SGD60 T1P	10177529	304.8	12.00	3.60	10177528				
LF-Acetal Top Plate/Stainless Steel Base Chain									
LF1873TAB SG SS-7.5IN 1SGD60 T1P	10177532	190.5	7.50	3.10	10177526	3400	457	CL 63 SS_KRV UKS BTL SP	10137637
LF1873TAB SG-10IN D60 SS	10373925	254.0	10.00	3.40	10177527				
LF1873TAB SG SS-12IN 1SGD60 T1P	10373923	304.8	12.00	3.60	10177528				

Standard length: 3.048 m – 10 feet (160 links).
Rubber: SEBS grey; 60 shore A hardness. Other rubber patterns and materials are possible.
Min. backflex radius 305 mm.

Minimum order quantity 30.48 m – 100 feet.

Gripper 1/2" Pitch Plastic Tab

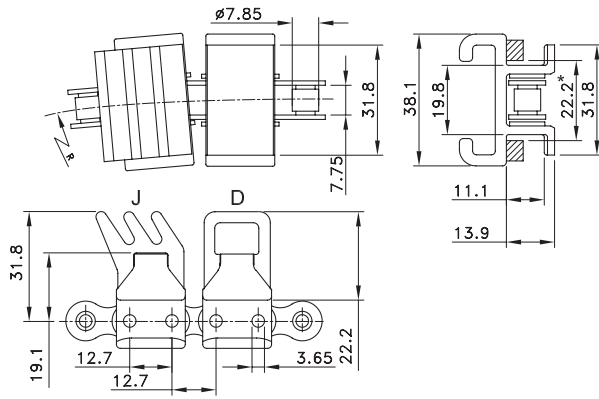
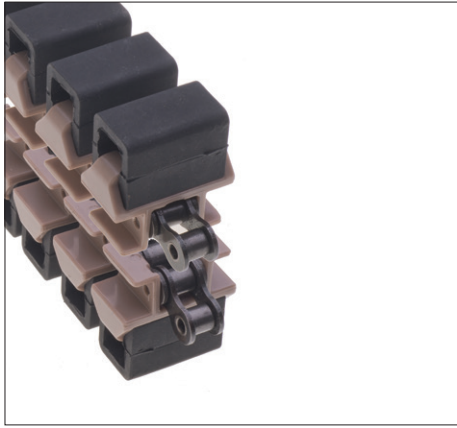

1843 MO Pin Plate
(Part #10084585)
Identifies Connector Link



1843 (SS) MO Pin Plate
(Part #10084587)
Identifies Connector Link



Chain Type	Code Number	Plate Width A		Weight kg/m	Working Load (max.) N (21°C)	Sideflex Radius (min) mm	Connection Link	
		mm	inch				Type	Code Number
LF-Acetal Top Plate/Steel Base Chain								
LF1843TAB GRIP S-1.5IN D NEO BK 40	10373972	38.1	1.50	1.20	2700	254	CONN LINK 1843 S	10084585
LF-Acetal Top Plate/Stainless Steel Base Chain								
LF1843TAB GRIP SS-1.5IN D NEO BK 40	10373974	38.1	1.50	1.20	1900	254	CONN LINK 1843 SS	10084587

Standard length: 3.048 m – 10 feet (240 links).

3-Finger Gripper 1/2" Pitch Plastic Tab

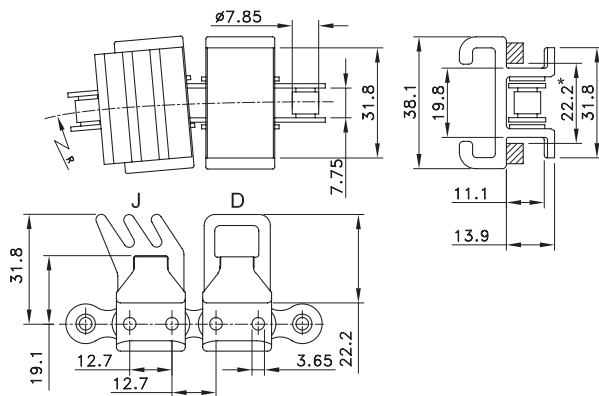
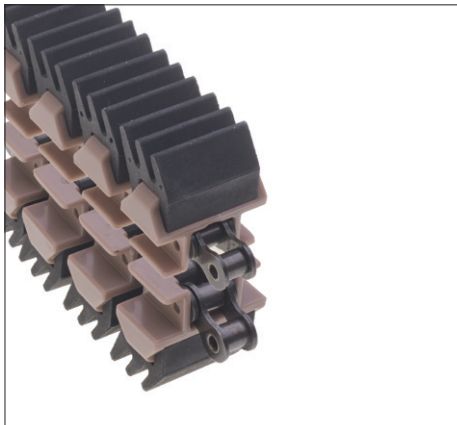

1843 MO Pin Plate
(Part #10084585)
Identifies Connector Link



1843 (SS) MO Pin Plate
(Part #10084587)
Identifies Connector Link



Chain Type	Code Number	Plate Width A		Weight kg/m	Working Load (max.) N (21°C)	Sideflex Radius (min) mm	Connection Link	
		mm	inch				Type	Code Number
LF-Acetal Top Plate/Steel Base Chain								
LF1843TAB GRIP S-1.5IN J NEO BK 40SH	10177557	38.1	1.50	1.20	2700	254	CONN LINK 1843 S	10084585
LF-Acetal Top Plate/Stainless Steel Base Chain								
LF1843TAB GRIP SS-1.5IN J NEO BK 40	10373975	38.1	1.50	1.20	1900	254	CONN LINK 1843 SS	10084587

Standard length: 3.048 m – 10 feet (240 links).

Snap-On Closed Gripper 3/4" Pitch Plastic Tab

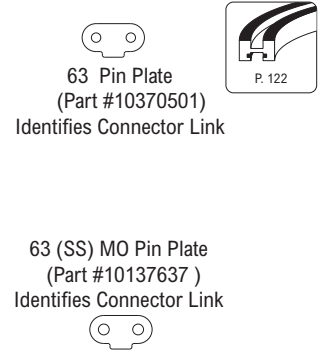
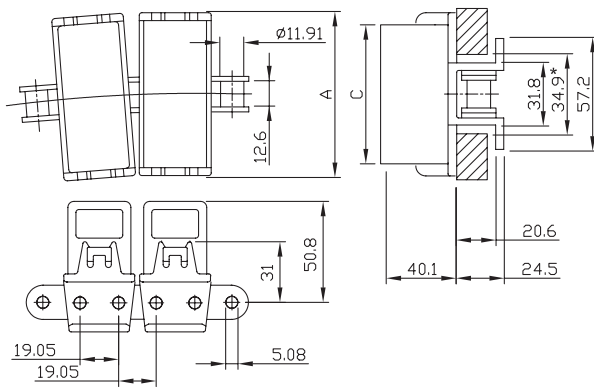
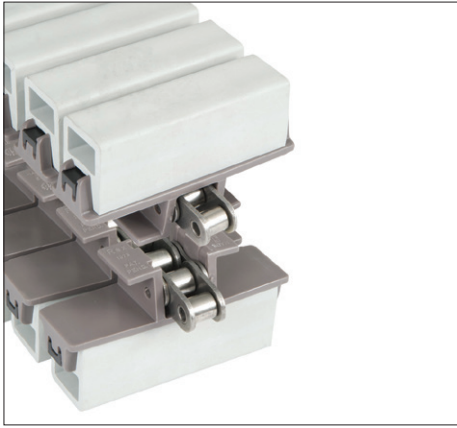

Chain Type	Code Number	Plate Width A		Gripper Width C	Weight	Working Load (max.) N (21°C)	Sideflex Radius (min) mm	Connection Link	
		mm	inch					Type	Code Number
HP-Acetal Top Plate/Steel Base Chain									
HP1873TAB GRIP S-3.25IN SD EPDM GY 50	10373940	82.5	3.25	70	2.90	4500	381	CL 63_BTL SP	10370501
HP1873TAB GRIP S-4.5IN SD EPDM GY 50	10373938	114.3	4.50	102	3.00				
HP-Acetal Top Plate/Stainless Steel Base Chain									
HP1873TAB GRIP SS-3.25IN SD EPDM GY 50	10373944	82.5	3.25	70	2.90	3400	381	CL 63_SS_KRV UKS BTL SP	10137637
HP1873TAB GRIP SS-4.5IN SD EPDM GY 50	10373936	114.3	4.50	102	3.00				

Standard length: 3.048 m – 10 feet (160 links).

Snap-On 2-Finger Gripper 3/4" Pitch Plastic Tab

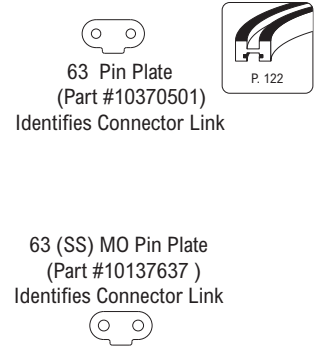
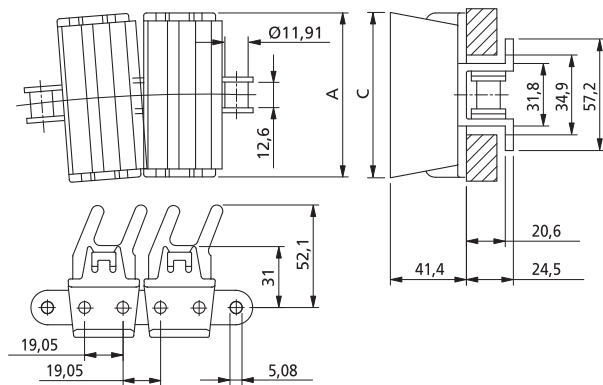
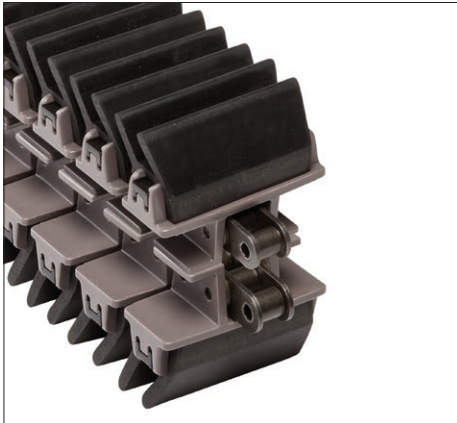

Chain Type	Code Number	Plate Width A		Gripper Width C	Weight	Working Load (max.) N (21°C)	Sideflex Radius (min) mm	Connection Link	
		mm	inch					Type	Code Number
HP-Acetal Top Plate /Steel Base Chain									
HP1873TAB GRIP S-3.25IN S2J EPDM BK 45	10373939	82.5	3.25	77	2.90	4500	381	CL 63_BTL SP	10370501
HP1873TAB GRIP S-4.5IN S2J EPDM BK 45	10373941	114.3	4.50	108	3.00				
HP-Acetal Top Plate /Stainless Steel Base Chain									
HP1873TAB GRIP SS-3.25IN S2J EPDM BK 45	10373943	82.5	3.25	77	2.90	3400	381	CL 63_SS_KRV UKS BTL SP	10137637
HP1873TAB GRIP SS-4.5IN S2J EPDM BK 45	10373945	114.3	4.50	108	3.00				

Standard length: 3.048 m – 10 feet (160 links).

Snap-On 3-Finger Gripper 3/4" Pitch Plastic Tab

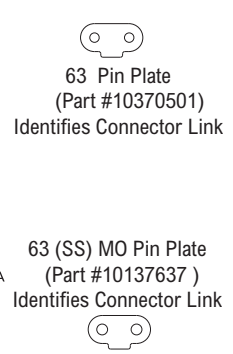
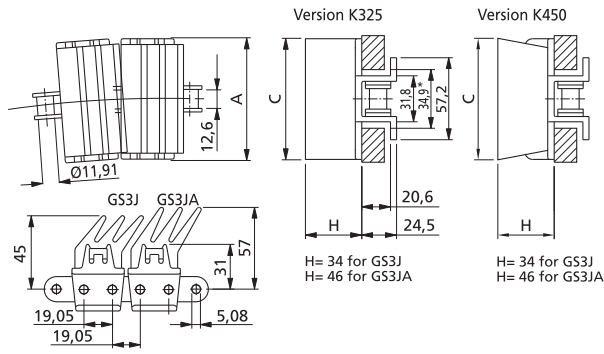
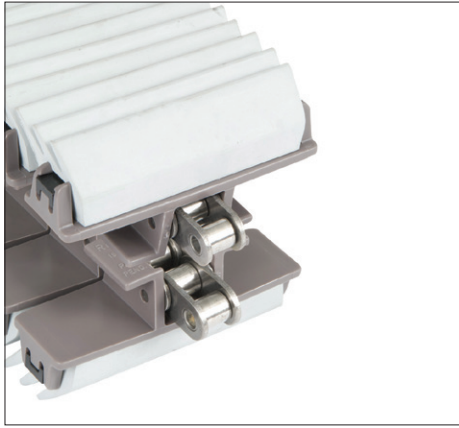

Chain Type	Code Number	Plate Width A		Gripper Width C	Weight	Working Load (max.)	Sideflex Radius (min)	Connection Link	
		mm	inch					Type	Code Number
HP-Acetal Top Plate/Steel Base Chain									
HP1873TAB GRIP S-3.25IN S3J EPDM GY 55	10301910	82.5	3.25	82.5	2.90	4500	381	CL 63_BTL SP	10370501
HP1873TAB GRIP S-4.5IN S3J EPDM GY 55	10373932	114.3	4.50	107	3.00				
HP-Acetal Top Plate/Stainless Steel Base Chain									
HP1873TAB GRIP SS-3.25IN S3J EPDM GY 55	10373942	82.5	3.25	82.5	2.90	3400	381	CL 63 SS_KRV UKS BTL SP	10137637
HP1873TAB GRIP SS-4.5IN S3J EPDM GY 55	10373917	114.3	4.50	107	3.00				
HP-Acetal Top Plate/Steel Base Chain									
HP1873TAB GRIP S-3.25IN S3JA EPDM GY 45	10177525	82.5	3.25	82.5	2.90	4500	381	CL 63_BTL SP	10370501
HP1873TAB GRIP S-4.5IN S3JA EPDM BK 45	10373933	114.3	4.50	109	3.00				
HP-Acetal Top Plate/Stainless Steel Base Chain									
HP1873TAB GRIP SS-3.25IN S3JA EPDM GY 45	10303011	82.5	3.25	82.5	2.90	3400	381	CL 63 SS_KRV UKS BTL SP	10137637
HP1873TAB GRIP SS-4.5IN S3JA EPDM BK 45	10373934	114.3	4.50	109	3.00				

Standard length: 3.048 m – 10 feet (160 links).

Snap-On 3-Finger Gripper 3/4" Pitch Steel Tab

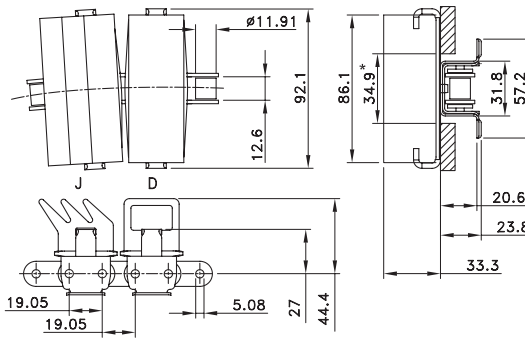
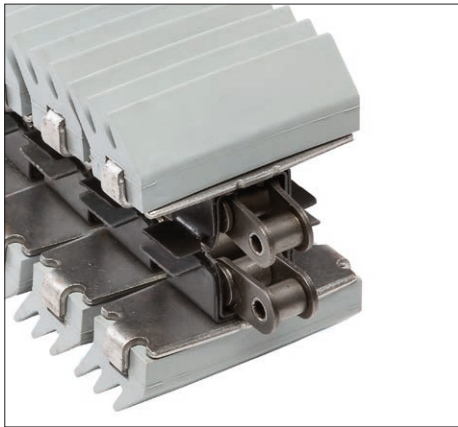



63 Pin Plate
 (Part #10370501)
 Identifies Connector Link



63 (SS) MO Pin Plate
 (Part #10137637)
 Identifies Connector Link

Chain Type	Code Number	Plate Width A		Gripper Width C	Working Load (max.)	Sideflex Radius (min)	Connection Link	
		mm	inch				Type	Code Number
Steel Top Plate/Steel Base Chain								
S1874TAB GRIP S-3.625IN D NEO BK 40	10373893	92.1	3.63	5.60	4500	381	CL 63_BTL SP	10370501
SS1874TAB GRIP SS-3.625IN J EPDM BK 50	10463288	92.1	3.63	5.60	4500	381	CL 63_BTL SP	10370501
Stainless Steel Top Plate/Stainless Steel Base Chain								
SS1874TAB GRIP SS-3.625IN D NEO BK 40	10373894	92.1	3.63	5.60	3400	381	CL 63 SS_KRV UKS BTL SP	10137637
SS1874TAB GRIP SS-3.625IN J EPDM BK 50	10463288	92.1	3.63	5.60	3400	381	CL 63 SS_KRV UKS BTL SP	10137637

Standard length: 3.048 m – 10 feet (160 links).

Per le catene curvilinee in acciaio e plastica, Rexnord offre le guide curve corrispondenti. Indubbiamente, Magnetflex® è considerato il sistema di curvatura migliore a livello mondiale. Il programma include inoltre curve e guide rettilinee per catene Bevel e TAB.

Systema Magnetflex®

Il sistema MCC Magnetflex® è diventato lo standard mondiale nell'industria delle bevande. I grandi vantaggi offerti da questo sistema brevettato ne hanno fatto la scelta dei principali OEM in tutto il mondo. Si tratta di un sistema combinato sia per catene di plastica che in acciaio. I magneti sotto alla guida tengono abbassata la catena in un modo molto affidabile.

Magnetflex® è l'unico sistema in cui due magneti coprono quasi l'intera base della curva, invece della sola guida. Poiché i magneti sono collegati da una piastra di acciaio, si forma un campo magnetico molto ampio. A differenza delle altre curve magnetiche, questo determina una forza che tiene abbassate le catene di plastica sia con perni di acciaio che catene di acciaio. Un altro vantaggio consiste nel fatto che la posizione del magnete ha una piccola riduzione nella forza di abbassamento quando la catena viene sollevata, in caso di presenza di sporcizia o vetro rotto, senza saltare via dalla guida. Mentre in altri sistemi le catene possono bloccarsi e incepparsi nel profilo della curva a causa della sporcizia, nel sistema Magnetflex® la catena si solleva semplicemente e continua ad avanzare. Le calamite vengono collocate nella curva ad angoli fissi, invece che a distanze fisse, per assicurarsi che nessun effetto di pulsazione venga creato dai magneti, quando una catena viene trainata in curva.

I magneti fanno in modo che tutte le catene poggino sulla curva perfettamente piatte, senza inclinarsi. In altri sistemi, la tensione della catena fa in modo che la catena utilizzi tutto il gioco nella guida della catena, determinando il sollevamento dei bordi della catena. Soprattutto nelle curve a più vie e trasporto ad alta velocità, questo comporta la caduta dei prodotti.

Un altro grande vantaggio del sistema Magnetflex® è la facile installazione delle catene e la possibilità di pulire perfettamente il sistema. Questo dipende dalla guida aperta e rettangolare nella curva. Le catene possono essere facilmente installate come se la curva fosse una parte rettilinea del trasportatore. Inoltre, la catena può essere facilmente sollevata dalla guida per le operazioni di manutenzione e pulizia, senza rompere la catena o addirittura rimuoverla dalla struttura del trasportatore.

Le curve Magnetflex® possono essere installate nel telaio del trasportatore in vari modi. I componenti superiore e di ritorno possono essere forniti fissati insieme e con inserti per il montaggio della curva assemblata nel telaio del trasportatore. L'opzione utilizzata più spesso nelle curve a più guide è quella di fornire separatamente la parte superiore e di ritorno. Queste vengono quindi montate contro una traversa del trasportatore. In tal caso, sia il componente superiore che quello di ritorno dispongono di inserti e/o fori. In entrambe le opzioni, il foro e gli inserti possono essere standard o specifici del cliente. La maggiore parte delle curve Magnetflex® dispone di un pattino. Questo pattino realizzato di lavorazione meccanica consente di portare la catena al livello giusto per l'ingresso nel componente di ritorno della curva. La posizione del pattino è determinata dalla struttura dei componenti di ritorno (in piano o sovrapposti) e dal tipo di catena. Una struttura sovrapposta viene utilizzata quando il passo tra le guide è troppo piccolo per consentire alle catene di scorrere allo stesso livello nel componente di ritorno. In tal caso, nel componente di ritorno sono presenti due livelli di guide: un livello in cui scorrono le guide non uniformi (1, 3, 5 ecc...) e uno in cui scorrono le guide uniformi. L'altezza del componente di ritorno sovrapposto (di solito 63 mm) è sempre superiore a quella del componente di ritorno non sovrapposto (di solito 55 mm).

Una versione speciale di una curva Magnetflex® è una curva CIP (Cleaning in Place), munita di ugelli di spruzzatura e tubi. Viene aperta il più possibile per consentire una buona pulizia della catena di acciaio o plastica e del profilo della curva dall'interno della curva. La curva CIP può essere integrata in un sistema CIP già esistente.

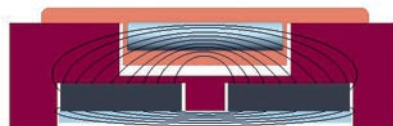

Curva magnetflex® con 2 magneti per un migliore attrazione della catena

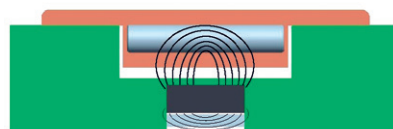

Curva magnetica tradizionale con 1 solo magnete

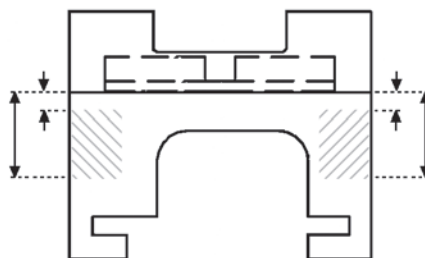

Componente superiore e di ritorno montato contro una traversa

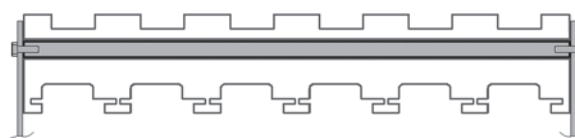

Componente superiore e di ritorno montato contro una traversa

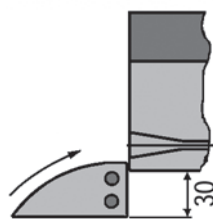

Componente di ritorno allo stesso livello

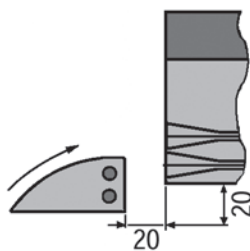

Componente di ritorno sovrapposto

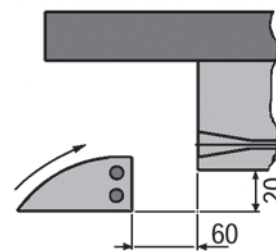

Nastri a catena

Una versione speciale di una curva Magnetflex® è una curva CIP (Cleaning in Place), munita di ugelli di spruzzatura e tubi. Viene aperta il più possibile per consentire una buona pulizia della catena di acciaio o plastica e del profilo della curva dall'interno della curva. La curva CIP può essere integrata in un sistema CIP già esistente.

Le curve Magnetflex® sono disponibili in cinque materiali diversi. Il materiale standard, Combi-A, è un polietilene di grado superiore. È adatto per la maggior parte delle applicazioni lubrificate con catene in acciaio e plastica. In ambienti puliti e con catene a bassa velocità, il Combi-A può essere utilizzato anche nelle applicazioni per utilizzo a secco. Per le applicazioni per utilizzo a secco con catene TableTop® di plastica, è consigliabile l'utilizzo di Combi-L e Combi-S. Questi materiali sono in grado di funzionare con catene a velocità più elevata. Combi-S ha il campo di applicazione più ampio, dove Combi-L offre una migliore riduzione del rumore. Il programma di calcolo Rexnord determina il carico PV (pressione-velocità) sulla curva in un'applicazione specifica e indica quale carico di applicazione e velocità è necessario per le curve Combi-L o Combi-S. Per le applicazioni lubrificate e abrasive (scarico di riempimento) oppure per le applicazioni abrasive, per utilizzo a secco (vetro) con catene in acciaio (inossidabile), Combi-G è l'ideale. Il polietilene rinforzato in ceramica offre un'ottima resistenza all'usura. Le Combi-X di Nuova Generazione possono essere utilizzate a secco in applicazioni ad elevate velocità.



Curve Material	Lubricated, clean, stainless steel chains, plastic chains	Lubricated, abrasive, stainless steel chains	Lubricated, abrasive, plastic chains	Dry running, low speed, abrasive, steel chains	Dry running, low speed, clean, plastic chains	Dry running, high speed, clean, plastic chains	Dry running, abrasive, plastic chains
Combi-X	Best choice	Optional	Best choice		Best choice		Best choice
Combi-A	Best choice				Best choice		
Combi-S				Optional		Optional	Best choice
Combi-G		Optional		Best choice			

Optional (orange) Best choice (green)

Magnetflex® Combi-X Nuova Generazione a costruzione ibrida

Una associazione brevettata di polimero, per la base portante, combinata con profili di guida in materiale ad alta prestazione ULF (Ultra Low Friction) conforme ai requisiti Food Grade che, connessi in modo permanente, realizzano una sinergia funzionale tra materiali differenti.

Ritorno tubolare Magnetflex®

Per garantire che la superficie delle catene TableTop® rimanga in condizioni perfette in applicazioni ad alta velocità, Rexnord ha sviluppato un ritorno tubolare in acciaio inossidabile che riduce l'usura abrasiva della superficie superiore della catena. Questo consente, alla superficie della catena, di rimanere in condizioni perfette per un lungo periodo di tempo.



Returnpart Equipped with Tubes

TAB e Bevel

In molti settori industriali, le curve Tab e Bevel e le guide rettilinee sono una soluzione economica se la stabilità del prodotto trasportato, la possibilità di pulizia e la facilità di installazione non sono le principali aree di interesse. Sono disponibili per le catene TableTop®, Multiflex® e Plate Top®. I profili lavorati Tab e Bevel trattengono meccanicamente le catene. Per queste guide viene utilizzato polietilene impermeabile di grado superiore. Normalmente sono nere, ma in casi particolari possono essere composte dai materiali utilizzati per le curve Magnetflex®.

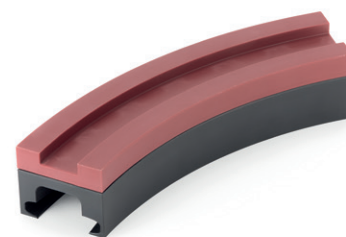

Combi-X Corner Track

Elevato limite PV

Le curve Magnetflex® Combi-X hanno proprietà PV migliorate rispetto alle curve standard Rexnord con Nylatron. Questo significa che le curve possono essere utilizzate a secco in applicazioni ad elevate velocità.

Curve personalizzate

Esistono oltre 50 versioni standard per diverse larghezze di catena, tipi di catena, passi di catena, materiali, lunghezze di entrata e uscita e modelli di fori/inserti. Se queste versioni standard non soddisfano le esigenze di trasporto specifiche, è possibile ordinare versioni personalizzate.

PV-Limit

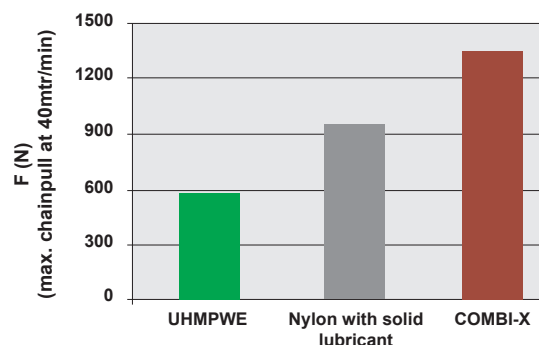

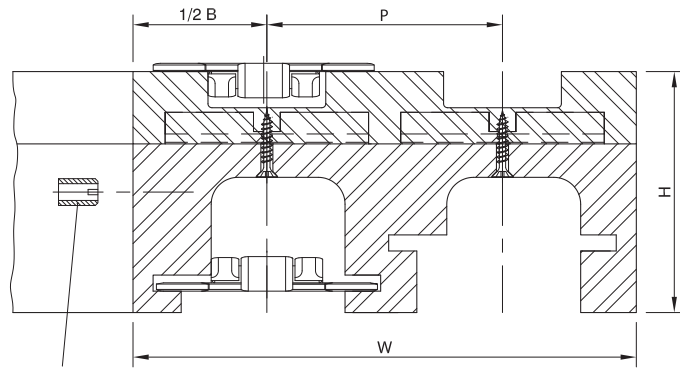
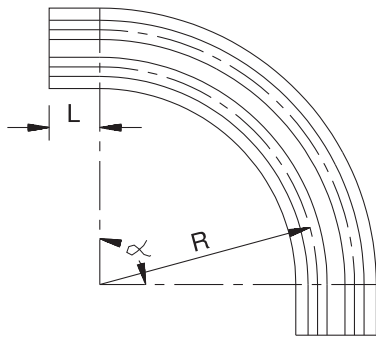

Selection Tables

Select your curve by reading the tables from left to right. You'll find more information on the specified pages.

For Chain Type (s)	Radius	Pitch	Basic Width	Infeed Length	Total Height	Version Number	See Page		
	R	P	B	L	H				
	mm	mm	mm	mm	mm				
For Chains With 3.25"/3.30" Plate Width									
Steel/Plastic	500	85	100	0	82 / 89	C7-CX7	109		
				100	90	C6-CX6	108		
			100	90	C4	106			
		90	100	90	C14	110			
			100	125	82	C1	103		
			100	100	82	C2	103		
	590	180	100	100	100	82	C3	106	
				110	0	82	C5B	on request	
			100	100	82	C5A	107		
		750	85	111	100	100	90	C42	110
					100	125	82	C5C	107
					100	0	82	C5D	on request
1000	85	111	100	100	90	C43	112		
			111	100	90	C43	112		
Cip-Curve for Chains With 3.25" Plate Width for Chains with 4.50" Plate Width									
661 steel	500	85	100	100	82	CF6	110		
Steel	500	85	111	100	100	CIP4	107		
Steel/plastic	500	120	129	125	90	C21A	111		
	610	120	129	125	90	C22A	111		
For Chains with 7.50" Plate Width									
Steel	610	196	214	125	90	C61	113		
	860	-	214	0	82	C66	114		
	1000	-	214	0	82	C65	114		
Steel / HDFM 750 (SG)	610	195	200	100	95	C81	115		
	860	-	214	0	87	C86	115		
For Chains with 10.00" Plate Width									
HDFM 1000 (SG)	860	-	290	0	87	C91	116		
For Chains with 12.00" Plate Width									
HDFM 1200 (SG)	860	-	340	0	87	C96	116		
For LBP Chains									
RHMD 325 LBP	500	90	100	100	90	LBP2	117		
HDFM 750 LBP	860	-	214	0	95	LBP861	117		
HDFM 1000 LBP	860	-	290	0	95	LBP91	118		
HDFM 1200 LBP	860	-	340	0	95	LBP96	118		
For Chainbelts									
FGM/FTM 1040/1060	500	85	100	100	90	CB6-CXB6	119		
FTM 1055 K330	500	85	100	100	90	CC6-CXC6	120		
FTM 1055 K450	500	120	129	125	90	CC21	121		

All these Magnetflex curves include a return guide shoe, except C7. Inserts are optional; M8 or M10 inserts in the return part and M6 or M8 inserts in the guide shoe can be supplied according your detailed drawing. If you need a special Magnetflex curve, following parameters are necessary:

1. Basic width
2. Radius
3. Infeed length
4. Pitch
5. Angle
6. Number of tracks

For tab and bevel curves see page 120-125.

Magnetflex Combi-A Version C1

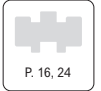
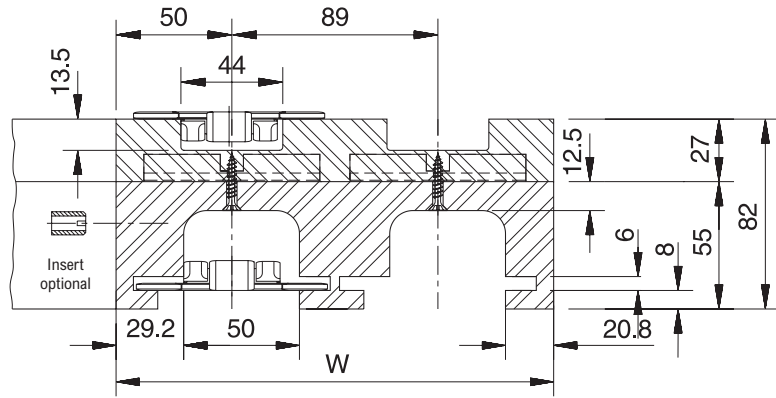

Number of Tracks	1	2	3	4	5	6
Width W	100 mm	189 mm	278 mm	367 mm	456 mm	545 mm

Version C1

15°	704.05.16	704.05.17	704.05.18	704.05.19	704.05.20	704.05.21
30°	704.05.31	704.05.32	704.05.33	704.05.34	704.05.35	704.05.36
45°	704.05.46	704.05.47	704.05.48	704.05.49	704.05.50	704.05.51
60°	704.05.61	704.05.62	704.05.63	704.05.64	704.05.65	704.05.66
75°	704.05.76	704.05.77	704.05.78	704.05.79	704.05.80	704.05.81
90°	704.05.01	704.05.02	704.05.03	704.05.04	704.05.05	704.05.06

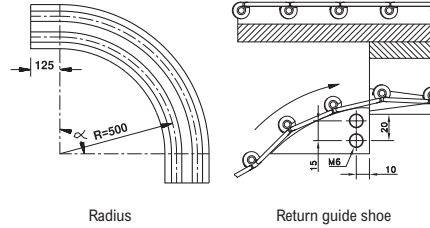

More than 6 tracks on request.

- For steel chains: 10/60/66 M 31 M, 60/66 M 31 XM, 66 M 31 RM, 60/66 M 84 XM.
- For plastic chains: RHMP 325, RHMDP 325, RHMP 84.

Magnetflex Combi-A Version C2

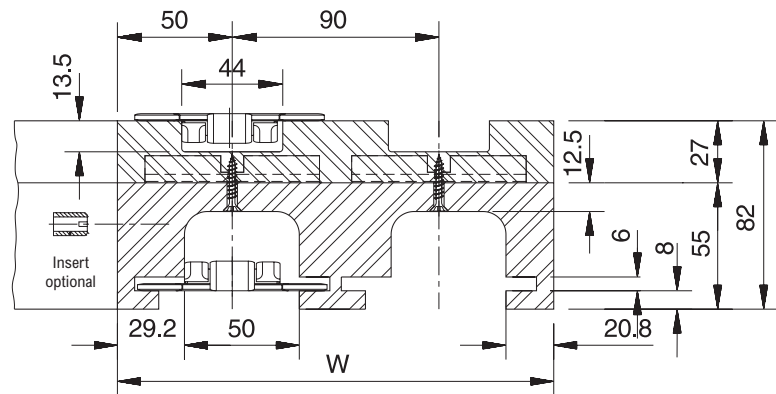

Number of Tracks	1	2	3	4	5	6
Width W	100 mm	190 mm	280 mm	370 mm	460 mm	550 mm

Version C2

15°	704.06.16	704.06.17	704.06.18	704.06.19	704.06.20	704.06.21
30°	704.06.31	704.06.32	704.06.33	704.06.34	704.06.35	704.06.36
45°	704.06.46	704.06.47	704.06.48	704.06.49	704.06.50	704.06.51
60°	704.06.61	704.06.62	704.06.63	704.06.64	704.06.65	704.06.66
75°	704.06.76	704.06.77	704.06.78	704.06.79	704.06.80	704.06.81
90°	704.06.01	704.06.02	704.06.03	704.06.04	704.06.05	704.06.06

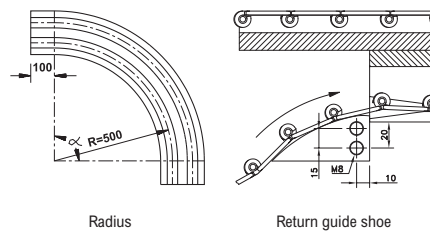

More than 6 tracks on request.

- For steel chains: 10/60/66 M 31 M, 60/66 M 31 XM, 66 M 31 RM, 60/66 M 84 XM.
- For plastic chains: RHMP 325, RHMDP 325, RHMP 84.

Magnetflex Combi-A Version C3

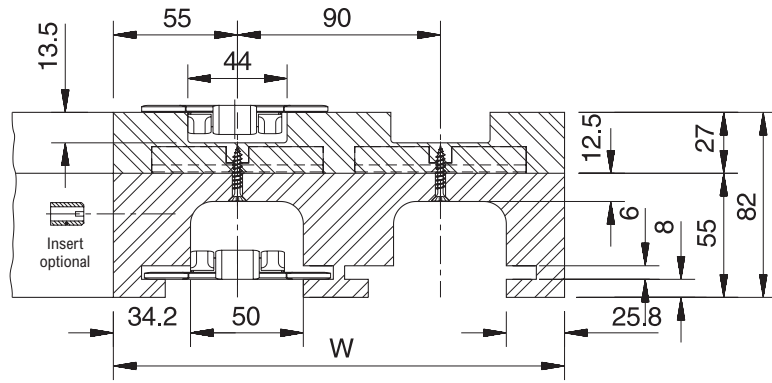

Number of Tracks	1	2	3	4	5	6
Width W	110 mm	200 mm	290 mm	380 mm	470 mm	560 mm
Version C3						
15°	704.07.16	704.07.17	704.07.18	704.07.19	704.07.20	704.07.21
30°	704.07.31	704.07.32	704.07.33	704.07.34	704.07.35	704.07.36
45°	704.07.46	704.07.47	704.07.48	704.07.49	704.07.50	704.07.51
60°	704.07.61	704.07.62	704.07.63	704.07.64	704.07.65	704.07.66
75°	704.07.76	704.07.77	704.07.78	704.07.79	704.07.80	704.07.81
90°	704.07.01	704.07.02	704.07.03	704.07.04	704.07.05	704.07.06

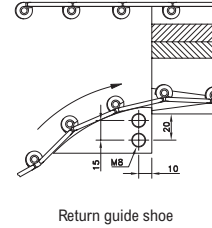
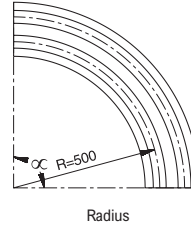

Radius

Return guide shoe

More than 6 tracks on request.

- For steel chains: 10/60/66 M 31 M, 60/66 M 31 XM, 66 M 31 RM, 60/66 M 84 XM.
- For plastic chains: RHMP 325, RHMDP 325, RHMP 84.

Magnetflex Combi-A Version C4

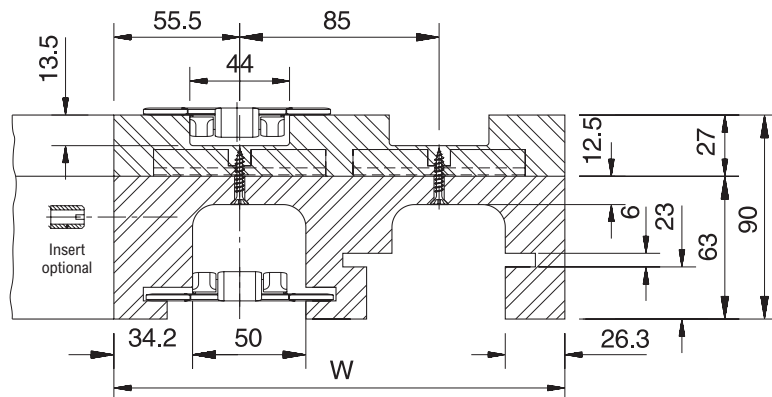
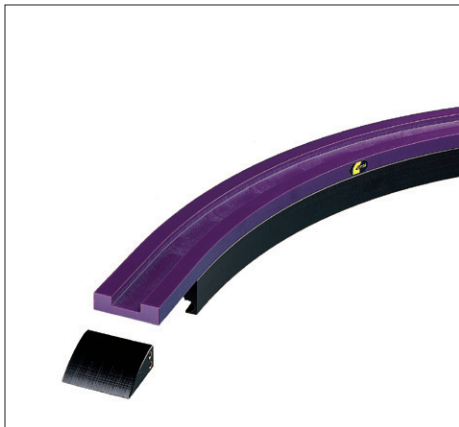

Number of Tracks	1	2	3	4	5	6
Width W	111 mm	196 mm	281 mm	366 mm	451 mm	536 mm
Version C4						
15°	704.08.16	704.08.17	704.08.18	704.08.19	704.08.20	704.08.21
30°	704.08.31	704.08.32	704.08.33	704.08.34	704.08.35	704.08.36
45°	704.08.46	704.08.47	704.08.48	704.08.49	704.08.50	704.08.51
60°	704.08.61	704.08.62	704.08.63	704.08.64	704.08.65	704.08.66
75°	704.08.76	704.08.77	704.08.78	704.08.79	704.08.80	704.08.81
90°	704.08.01	704.08.02	704.08.03	704.08.04	704.08.05	704.08.06

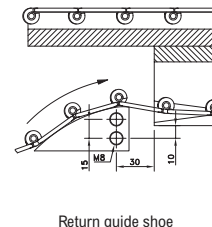
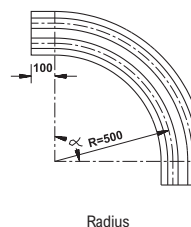

Radius

Return guide shoe

More than 6 tracks on request.

- For steel chains: 10/60/66 M 31 M, 60/66 M 31 XM, 66 M 31 RM, 60/66 M 84 XM.
- For plastic chains: RHMP 325, RHMDP 325, RHMP 84.

Magnetflex Version CIP4

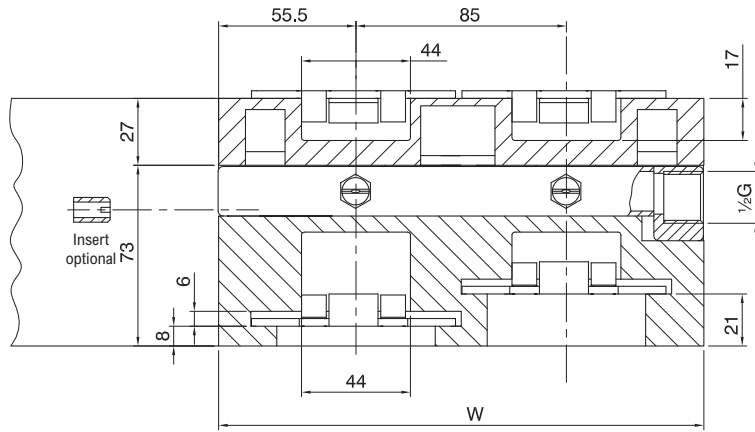

Number of Tracks	1	2	3	4	5	6
Width W	111 mm	196 mm	281 mm	366 mm	451 mm	536 mm

Version CIP4

15°	785.45.16	785.45.17	785.45.18	785.45.19	785.45.20	785.45.21
30°	785.45.31	785.45.32	785.45.33	785.45.34	785.45.35	785.45.36
45°	785.45.46	785.45.47	785.45.48	785.45.49	785.45.50	785.45.51
60°	785.45.61	785.45.62	785.45.63	785.45.64	785.45.65	785.45.66
75°	785.45.76	785.45.77	785.45.78	785.45.79	785.45.80	785.45.81
90°	785.45.01	785.45.02	785.45.03	785.45.04	785.45.05	785.45.06

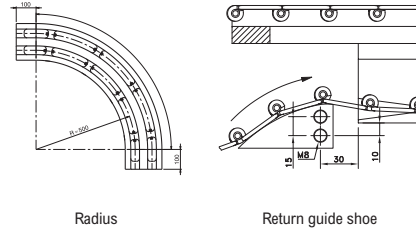

More than 6 tracks on request.

• For steel chains: 10/60/66 M 31 M, 60/66 M 31 XM, 66 M 31 RM, 60/66 M 84 XM.

Magnetflex Combi-A Version C5A-C5C

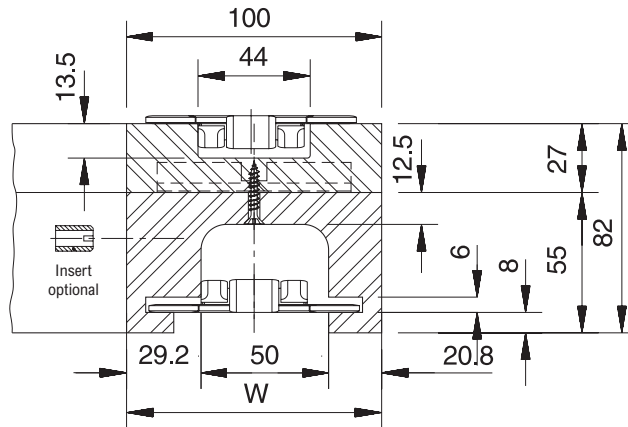
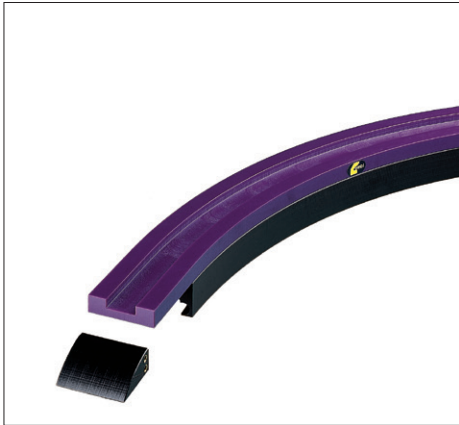

Number of Tracks	1
Width W	100 mm

Version C5A

15°	704.09.16
30°	704.09.31
45°	704.09.46
60°	704.09.61
75°	704.09.76
90°	704.09.01

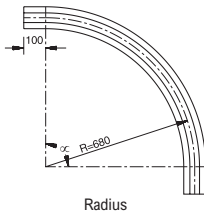

Number of Tracks	1
Width W	100 mm

Version C5C

15°	704.11.16
30°	704.11.31
45°	704.11.46
60°	704.11.61
75°	704.11.76
90°	704.11.01

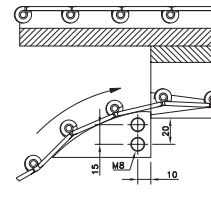
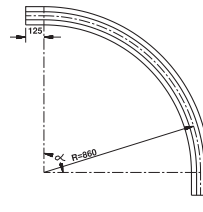

More than 1 track on request.

• For steel chains: 10/60/66 M 31 M, 60/66 M 31 SM, 66 M 31 RM, 60/66 M 84 SM.
• For plastic chains: RHMP 325, RHMDP 325, RHMP 84.

More than 1 track on request.

• For steel chains: 10/60/66 M 31 M, 60/66 M 31 SM, 66 M 31 RM, 60/66 M 84 SM, SSC 581 M-K325.
• For plastic chains: RHMP 325, RHMDP 325, RHMP 84.

Magnetflex Combi-A Version C6

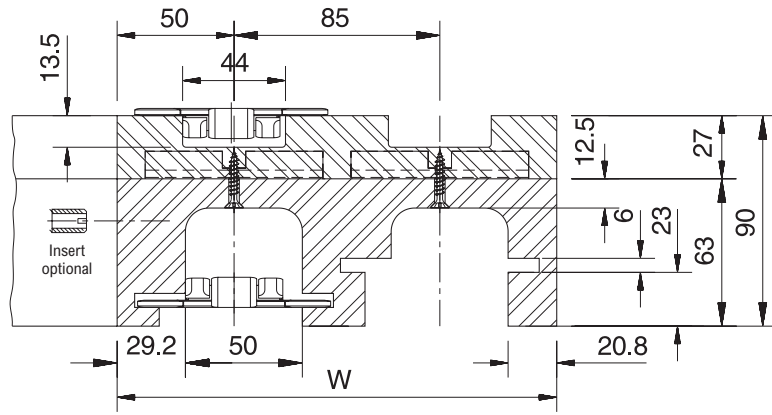

Number of Tracks	1	2	3	4	5	6
Width W	100 mm	185 mm	270 mm	355 mm	440 mm	525 mm
Version C6						
15°	704.14.16	704.14.17	704.14.18	704.14.19	704.14.20	704.14.21
30°	704.14.31	704.14.32	704.14.33	704.14.34	704.14.35	704.14.36
45°	704.14.46	704.14.47	704.14.48	704.14.49	704.14.50	704.14.51
60°	704.14.61	704.14.62	704.14.63	704.14.64	704.14.65	704.14.66
75°	704.14.76	704.14.77	704.14.78	704.14.79	704.14.80	704.14.81
90°	704.14.01	704.14.02	704.14.03	704.14.04	704.14.05	704.14.06

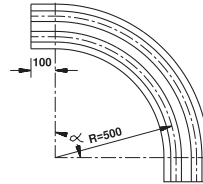

Radius

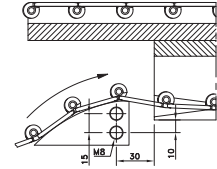

Return guide shoe

More than 6 tracks on request.

- For steel chains: 10/60/66 M 31 M, 60/66 M 31 XM, 66 M 31 RM, 60/66 M 84 XM.
- For plastic chains: RHMP 325, RHMDP 325, RHMP 84.

Magnetflex Combi-X Version CX6

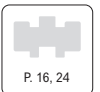
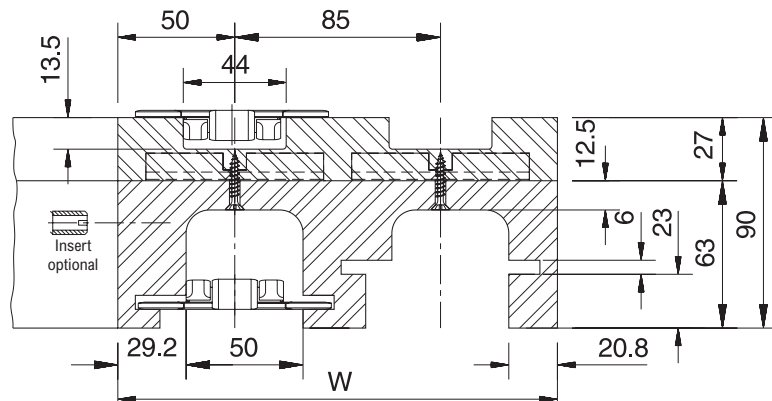
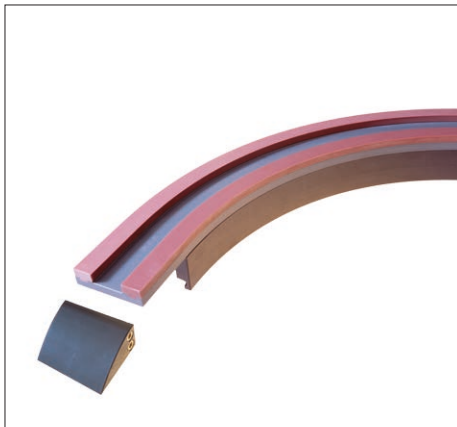

Number of Tracks	1	2	3	4	5	6
Width W	100 mm	185 mm	270 mm	355 mm	440 mm	525 mm
Version CX6						
15°	704.41.16	704.41.17	704.41.18	704.41.19	704.41.20	704.41.21
30°	704.41.31	704.41.32	704.41.33	704.41.34	704.41.35	704.41.36
45°	704.41.46	704.41.47	704.41.48	704.41.49	704.41.50	704.41.51
60°	704.41.61	704.41.62	704.41.63	704.41.64	704.41.65	704.41.66
75°	704.41.76	704.41.77	704.41.78	704.41.79	704.41.80	704.41.81
90°	704.41.01	704.41.02	704.41.03	704.41.04	704.41.05	704.41.06

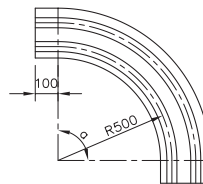

Radius

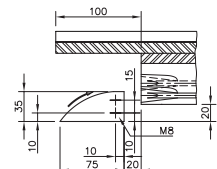

Return guide shoe

More than 6 tracks on request.

- For steel chains: 10/60/66 M 31 M, 60/66 M 31 XM, 66 M 31 RM, 60/66 M 84 XM.
- For plastic chains: RHMP 325, RHMDP 325, RHMP 84.

Magnetflex Combi-A Version C7

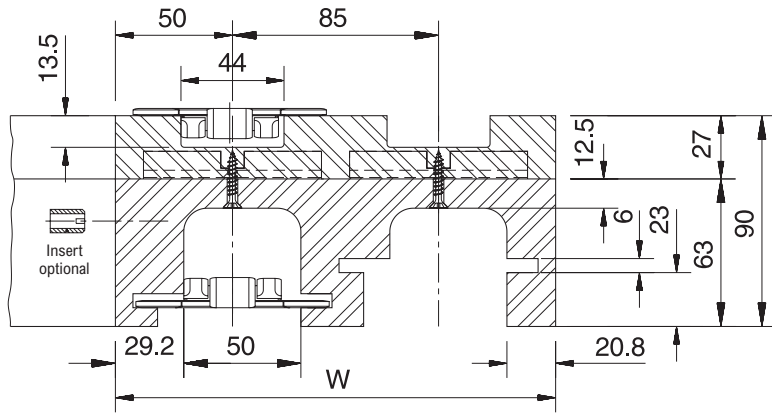

Number of Tracks	1	2	3	4	5	6
Width W	100 mm	185 mm	270 mm	355 mm	440 mm	525 mm

Version C7

15°	704.15.16	704.15.17	704.15.18	704.15.19	704.15.20	704.15.21
30°	704.15.31	704.15.32	704.15.33	704.15.34	704.15.35	704.15.36
45°	704.15.46	704.15.47	704.15.48	704.15.49	704.15.50	704.15.51
60°	704.15.61	704.15.62	704.15.63	704.15.64	704.15.65	704.15.66
75°	704.15.76	704.15.77	704.15.78	704.15.79	704.15.80	704.15.81
90°	704.15.01	704.15.02	704.15.03	704.15.04	704.15.05	704.15.06

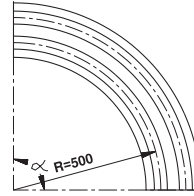

Radius

No return guide shoe

More than 6 tracks on request. The height of the return part is 55 mm in case of a single track C7.

- For steel chains: 10/60/66 M 31 M, 60/66 M 31 XM, 66 M 31 RM, 60/66 M 84 XM.
- For plastic chains: RHMP 325, RHMDP 325, RHMP 84.

Magnetflex Combi-X Version CX7

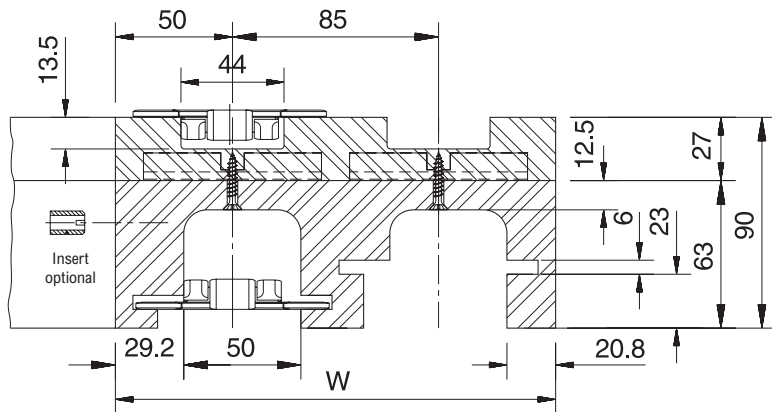
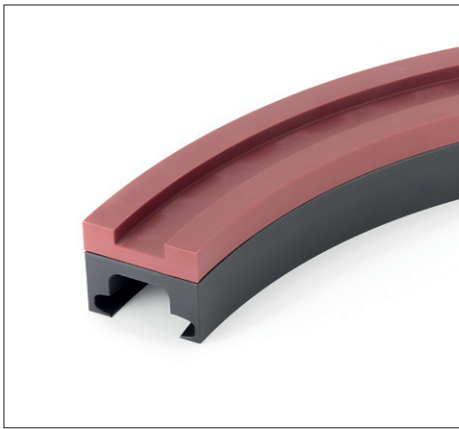

Number of Tracks	1	2	3	4	5	6
Width W	100 mm	185 mm	270 mm	355 mm	440 mm	525 mm

Version CX7

15°	704.42.16	704.42.17	704.42.18	704.42.19	704.42.20	704.42.21
30°	704.42.31	704.42.32	704.42.33	704.42.34	704.42.35	704.42.36
45°	704.42.46	704.42.47	704.42.48	704.42.49	704.42.50	704.42.51
60°	704.42.61	704.42.62	704.42.63	704.42.64	704.42.65	704.42.66
75°	704.42.76	704.42.77	704.42.78	704.42.79	704.42.80	704.42.81
90°	704.42.01	704.42.02	704.42.03	704.42.04	704.42.05	704.42.06

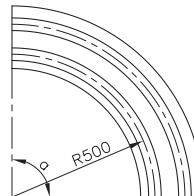

Radius

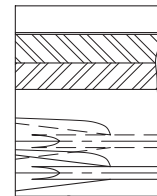

Return guide shoe

More than 6 tracks on request. The height of the return part is 55 mm in case of a single track C7.

- For steel chains: 10/60/66 M 31 M, 60/66 M 31 XM, 66 M 31 RM, 60/66 M 84 XM.
- For plastic chains: RHMP 325, RHMDP 325, RHMP 84.

Magnetflex Combi-A Version C14

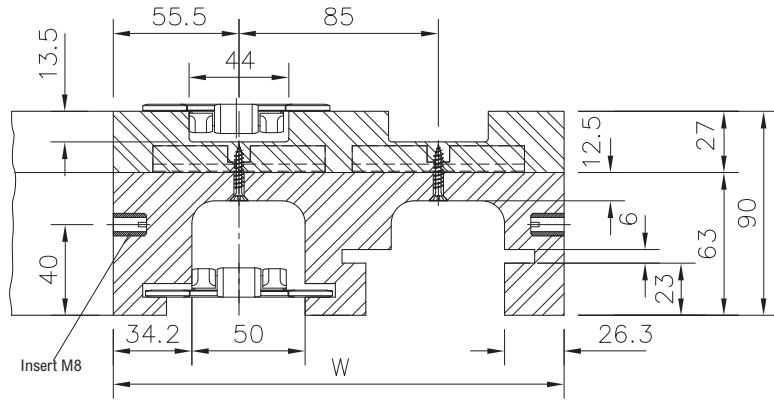

Number of Tracks	1	2	3	4	5	6
Width W	111 mm	196 mm	281 mm	366 mm	451 mm	536 mm

Version C14

15°	704.19.16	704.19.17	704.19.18	704.19.19	704.19.20	704.19.21
30°	704.19.31	704.19.32	704.19.33	704.19.34	704.19.35	704.19.36
45°	704.19.46	704.19.47	704.19.48	704.19.49	704.19.50	704.19.51
60°	704.19.61	704.19.62	704.19.63	704.19.64	704.19.65	704.19.66
75°	704.19.76	704.19.77	704.19.78	704.19.79	704.19.80	704.19.81
90°	704.19.01	704.19.02	704.19.03	704.19.04	704.19.05	704.19.06

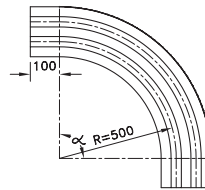

Radius

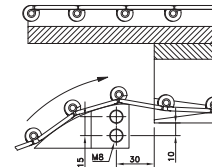

Return guide shoe

More than 6 tracks on request. C14 curves include inserts, of which the pattern varies per angle.
 • For steel chains: 10/60/66 M 31 M, 60/66 M 31 XM, 66 M 31 RM, 60/66 M 84 XM.
 • For plastic chains: RHMP 325, RHMDP 325, RHMP 84.

Magnetflex Combi-A Version CF6

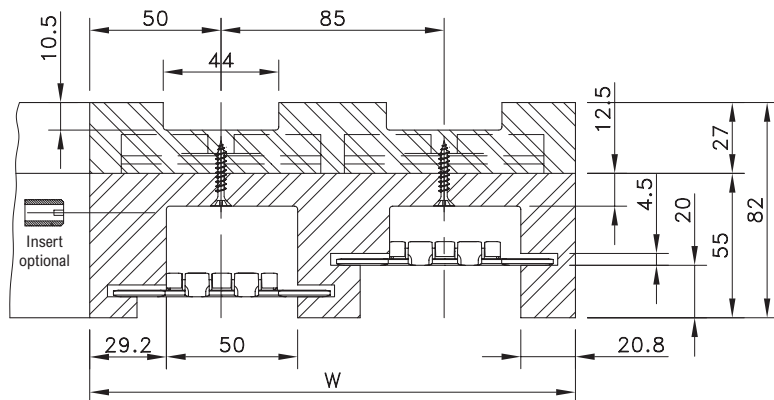

Number of Tracks	1	2	3	4	5	6
Width W	100 mm	185 mm	270 mm	355 mm	440 mm	525 mm

Version CF6

15°	624.38.16	624.38.17	624.38.18	624.38.19	624.38.20	624.38.21
30°	624.38.31	624.38.32	624.38.33	624.38.34	624.38.35	624.38.36
45°	624.38.46	624.38.47	624.38.48	624.38.49	624.38.50	624.38.51
60°	624.38.61	624.38.62	624.38.63	624.38.64	624.38.65	624.38.66
75°	624.38.76	624.38.77	624.38.78	624.38.79	624.38.80	624.38.81
90°	624.38.01	624.38.02	624.38.03	624.38.04	624.38.05	624.38.06

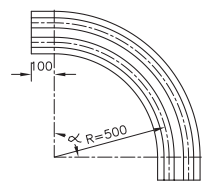

Radius

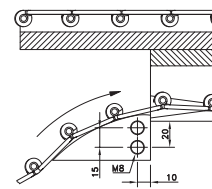

Return guide shoe

More than 6 tracks on request.
 • Other curves, such as CF4, CF7, CF42 and CF5C can be supplied as well. Please ask Technical Support for all details.
 • For steel chains: 661 M 31 SM, 661 M 84 SM.

Magnetflex Combi-A Version C21A

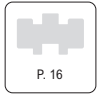
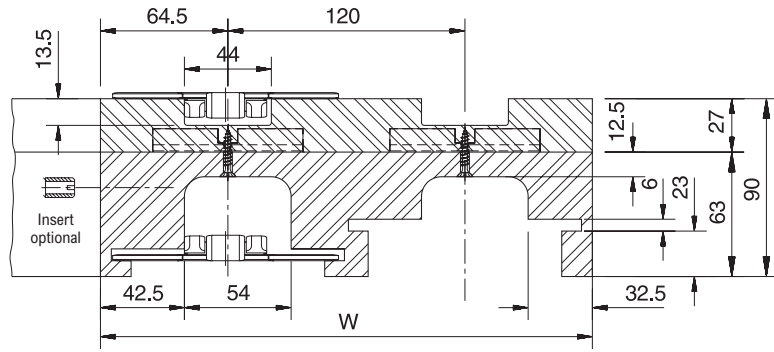
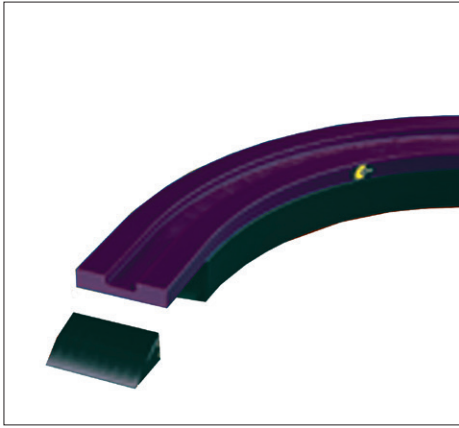

Number of Tracks	1	2	3	4
Width W	129 mm	249 mm	369 mm	489 mm

Version C21A

15°	714.08.16	714.08.17	714.08.18	714.08.19
30°	714.08.31	714.08.32	714.08.33	714.08.34
45°	714.08.46	714.08.47	714.08.48	714.08.49
60°	714.08.61	714.08.62	714.08.63	714.08.64
75°	714.08.76	714.08.77	714.08.78	714.08.79
90°	714.08.01	714.08.02	714.08.03	714.08.04

More than 4 tracks on request.

- For steel chains: 10/60 M 42 M.
- For plastic chains: RHM 450, RHMD 450.

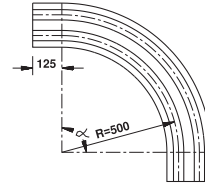

Radius

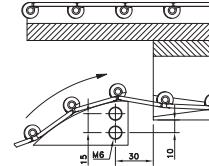

Return guide shoe

Magnetflex Combi-A Version C22A

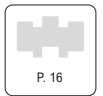
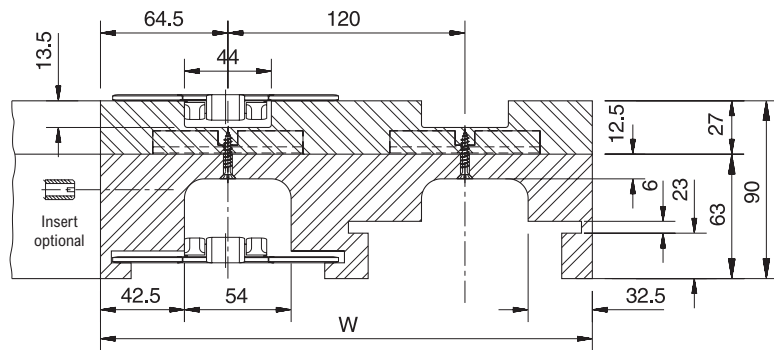
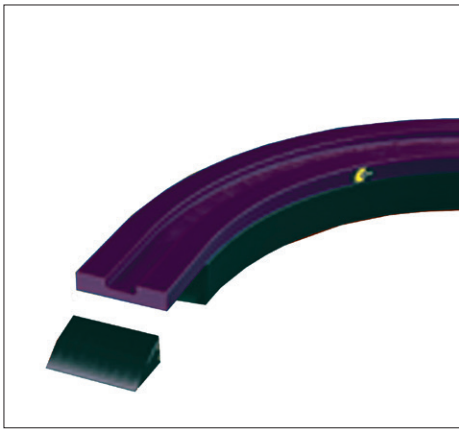

Number of Tracks	1	2	3	4
Width W	129 mm	249 mm	369 mm	489 mm

Version C22A

15°	714.09.16	714.09.17	714.09.18	714.09.19
30°	714.09.31	714.09.32	714.09.33	714.09.34
45°	714.09.46	714.09.47	714.09.48	714.09.49
60°	714.09.61	714.09.62	714.09.63	714.09.64
75°	714.09.76	714.09.77	714.09.78	714.09.79
90°	714.09.01	714.09.02	714.09.03	714.09.04

More than 4 tracks on request.

- For steel chains: 10/60 M 42 M.
- For plastic chains: RHM 450, RHMD 450.

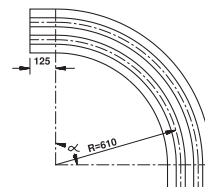

Radius

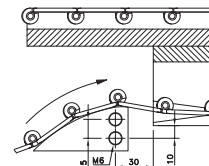

Return guide shoe

Magnetflex Combi-A Version C42

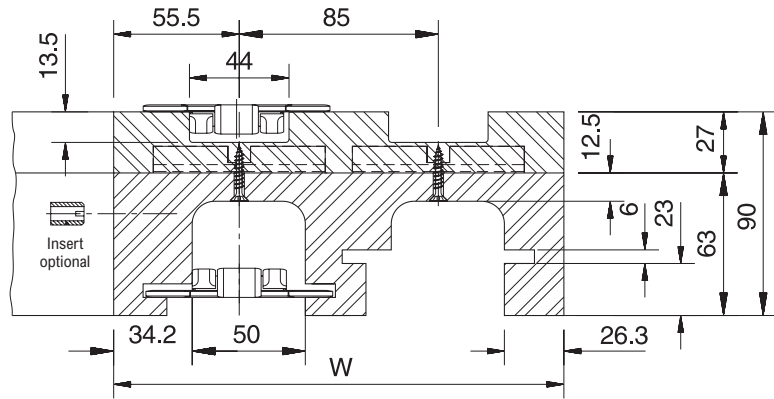

Number of Tracks	1	2	3	4	5	6
Width W	111 mm	196 mm	281 mm	366 mm	451 mm	536 mm

Version C42

15°	704.28.16	704.28.17	704.28.18	704.28.19	704.28.20	704.28.21
30°	704.28.31	704.28.32	704.28.33	704.28.34	704.28.35	704.28.36
45°	704.28.46	704.28.47	704.28.48	704.28.49	704.28.50	704.28.51
60°	704.28.61	704.28.62	704.28.63	704.28.64	704.28.65	704.28.66
75°	704.28.76	704.28.77	704.28.78	704.28.79	704.28.80	704.28.81
90°	704.28.01	704.28.02	704.28.03	704.28.04	704.28.05	704.28.06

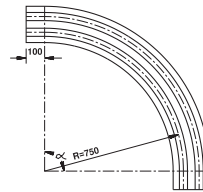

Radius

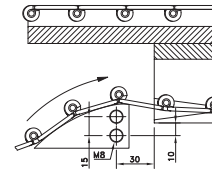

Return guide shoe

More than 6 tracks on request.

- For steel chains: 10/60/66 M 31 M, 60/66 M 31 XM, 66 M 31 RM, 60/66 M 84 XM.
- For plastic chains: RHMP 325, RHMDP 325, RHMP 84.

Magnetflex Combi-A Version C43

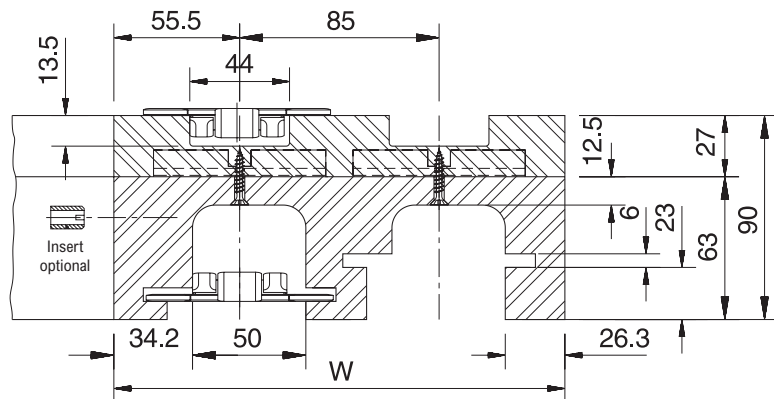

Number of Tracks	1	2	3	4	5	6
Width W	111 mm	196 mm	281 mm	366 mm	451 mm	536 mm

Version C43

15°	704.29.16	704.29.17	704.29.18	704.29.19	704.29.20	704.29.21
30°	704.29.31	704.29.32	704.29.33	704.29.34	704.29.35	704.29.36
45°	704.29.46	704.29.47	704.29.48	704.29.49	704.29.50	704.29.51
60°	704.29.61	704.29.62	704.29.63	704.29.64	704.29.65	704.29.66
75°	704.29.76	704.29.77	704.29.78	704.29.79	704.29.80	704.29.81
90°	704.29.01	704.29.02	704.29.03	704.29.04	704.29.05	704.29.06

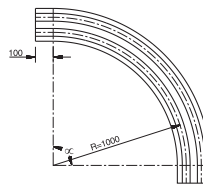

Radius

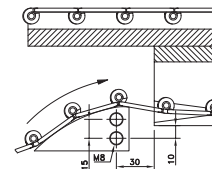

Return guide shoe

More than 6 tracks on request.

- For steel chains: 10/60/66 M 31 M, 60/66 M 31 XM, 66 M 31 RM, 60/66 M 84 XM, SSC 581 M-K325.
- For plastic chains: RHMP 325, RHMDP 325, RHMP 84.

Magnetflex Combi-A Version C61

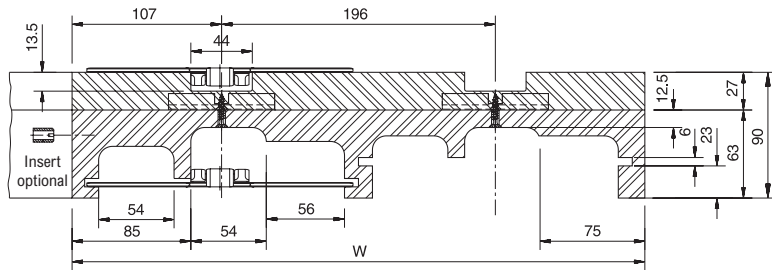
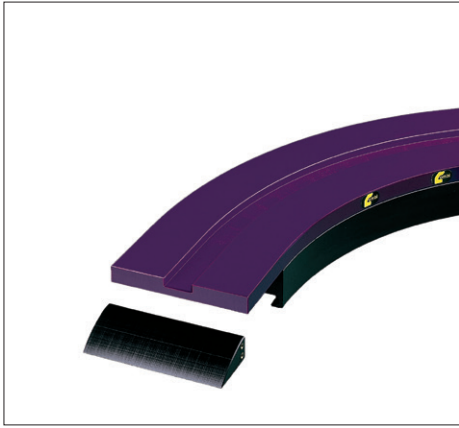

Number of Tracks	1	2	3	4
Width W	214 mm	410 mm	606 mm	802 mm

Version C61

15°	724.05.16	724.05.17	724.05.18	724.05.19
30°	724.05.31	724.05.32	724.05.33	724.05.34
45°	724.05.46	724.05.47	724.05.48	724.05.49
60°	724.05.61	724.05.62	724.05.63	724.05.64
75°	724.05.76	724.05.77	724.05.78	724.05.79
90°	724.05.01	724.05.02	724.05.03	724.05.04

More than 4 tracks on request.

• For steel chains: 10/60/66 M 72 M, 66 M 72 RM.

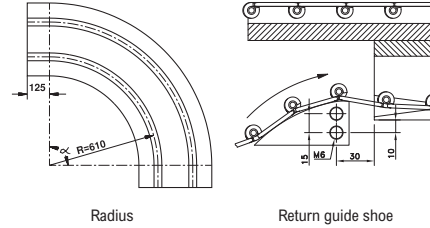

Magnetflex Combi-A Version C6T

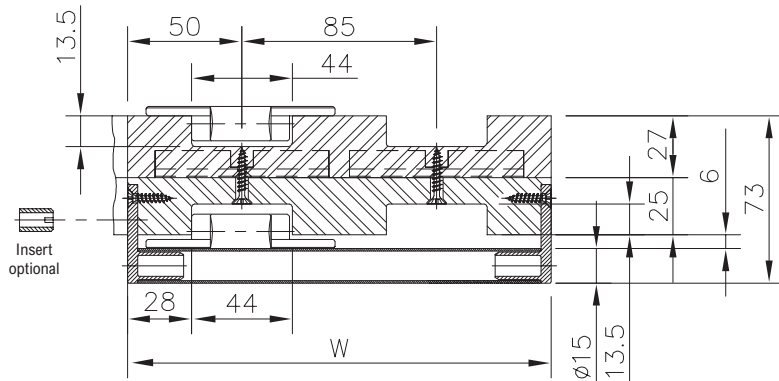

Number of Tracks	1	2	3	4	5	6
Width W	100 mm	185 mm	270 mm	355 mm	340 mm	525 mm

Version C6T

15°	704.32.16	704.32.17	704.32.18	704.32.19	704.32.20	704.32.21
30°	704.32.31	704.32.32	704.32.33	704.32.34	704.32.35	704.32.36
45°	704.32.46	704.32.47	704.32.48	704.32.49	704.32.50	704.32.51
60°	704.32.61	704.32.62	704.32.63	704.32.64	704.32.65	704.32.66
75°	704.32.76	704.32.77	704.32.78	704.32.79	704.32.80	704.32.81
90°	704.32.01	704.32.02	704.32.03	704.32.04	704.32.05	704.32.06

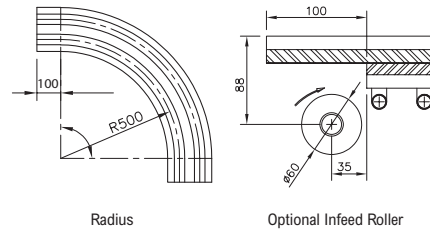

More than 6 tracks on request.

• For plastic chains: RHMP 325, RHMDP 325, RHMP 84.

• Not suitable for steel chains.

Also available in the following executions:

• COMBI A VERSION CB6T suitable for: FGM 1050 and FTM 1060 chainbelts.

• COMBI A VERSION CC6T suitable for: FTM 1055 chainbelts.

Magnetflex Combi-A Version C65

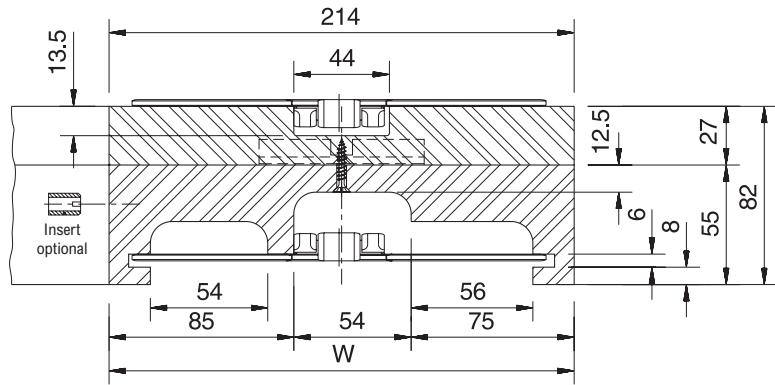

Number of Tracks	1
Width W	214 mm

Version C65

15°	724.07.16
30°	724.07.31
45°	724.07.46
60°	724.07.61
75°	724.07.76
90°	724.07.01

More than 1 track on request.

• For steel chains: 10/60/66 M 72 M, 66 M 72 RM.

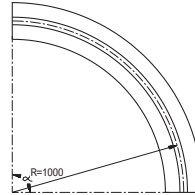

Radius

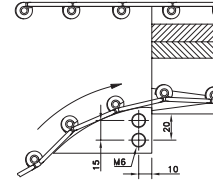

Return guide shoe

Magnetflex Combi-A Version C66

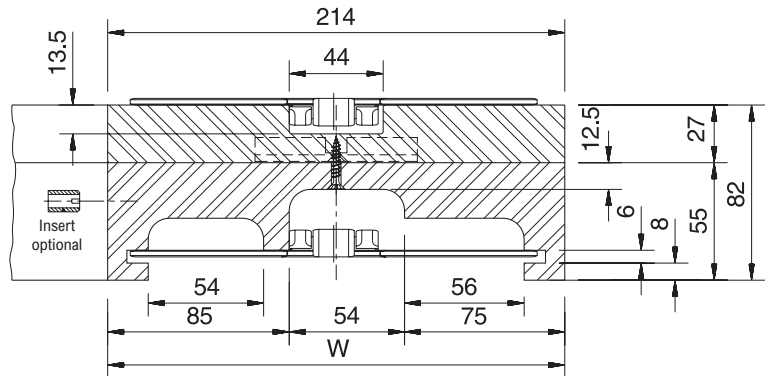

Number of Tracks	1
Width W	214 mm

Version C66

15°	724.11.16
30°	724.11.31
45°	724.11.46
60°	724.11.61
75°	724.11.76
90°	724.11.01

More than 1 track on request.

• For steel chains: 10/60/66 M 72 M, 66 M 72 RM.

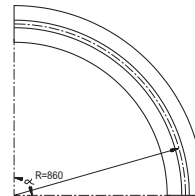

Radius

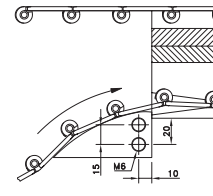

Return guide shoe

Magnetflex Combi-A Version C81

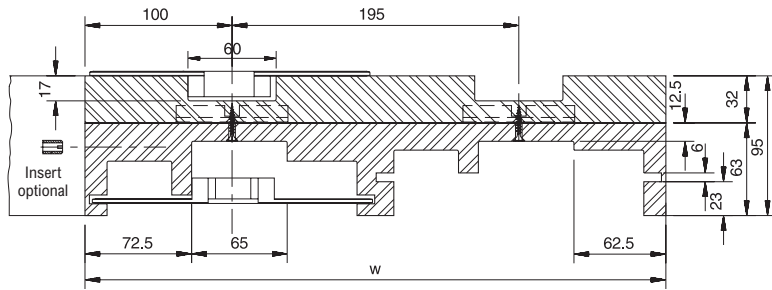

Number of Tracks	1	2	3	4
Width W	200 mm	395 mm	590 mm	785 mm

Version C81

15°	724.31.16	724.31.17	724.31.18	724.31.19
30°	724.31.31	724.31.32	724.31.33	724.31.34
45°	724.31.46	724.31.47	724.31.48	724.31.49
60°	724.31.61	724.31.62	724.31.63	724.31.64
75°	724.31.76	724.31.77	724.31.78	724.31.79
90°	724.31.01	724.31.02	724.31.03	724.31.04

More than 4 tracks on request.

• For plastic chains: HDFM 750 LF/SG.

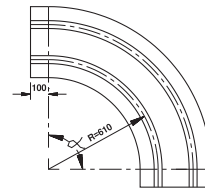

Radius

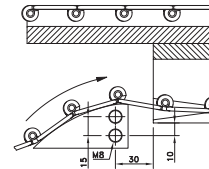

Return guide shoe

Magnetflex Combi-A Version C86

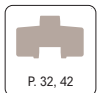
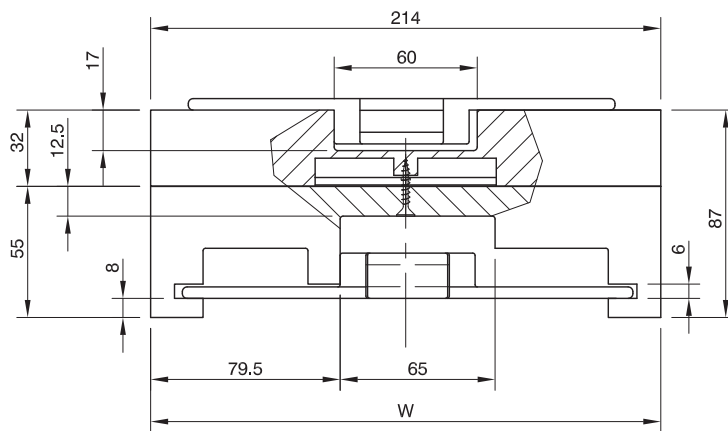

Number of Tracks	1
Width W	214 mm

Version C86

15°	724.36.16
30°	724.36.31
45°	724.36.46
60°	724.36.61
75°	724.36.76
90°	724.36.01

More than 1 track on request.

• For steel chains: 60/66 M 75 M, 66 M 75 RM.

• For plastic chains: HDFM 750 LF/SG.

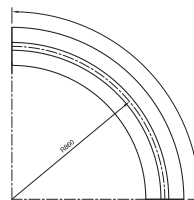

Radius

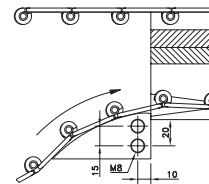

Return guide shoe

Magnetflex Combi-A Version C91

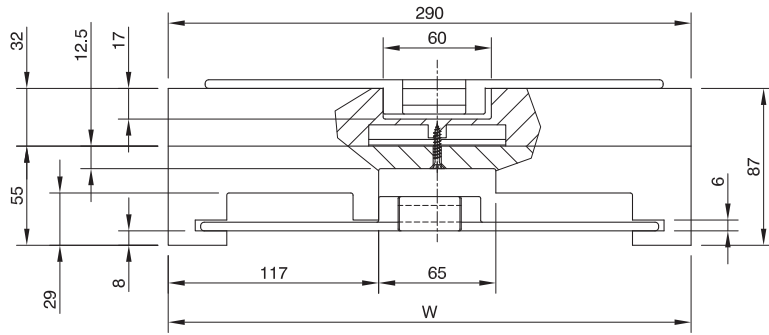
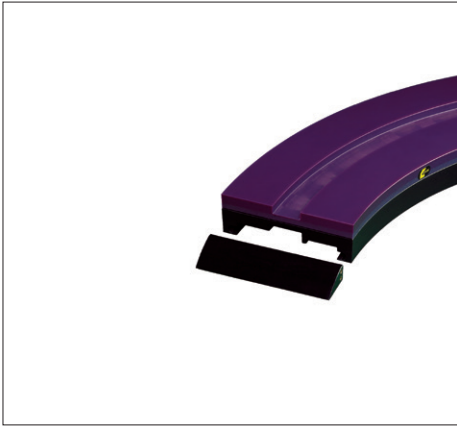

Number of Tracks	1
Width W	290 mm

Version C91	
15°	724.42.16
30°	724.42.31
45°	724.42.46
60°	724.42.61
75°	724.42.76
90°	724.42.01

More than 1 track on request.
 • For plastic chains: HDFM 1000 LF/SG.

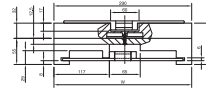

Radius

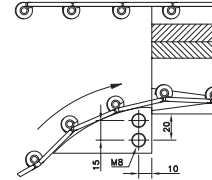

Return guide shoe

Magnetflex Combi-A Version C96

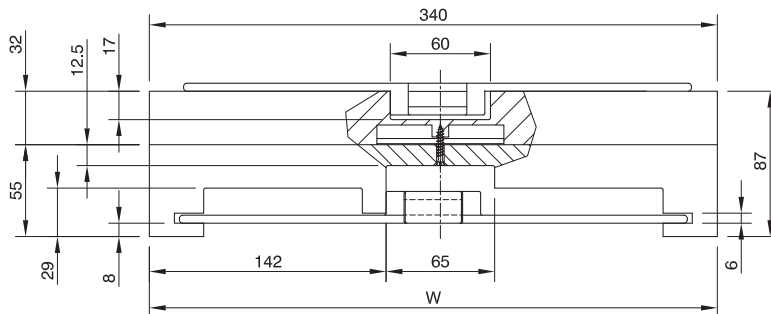
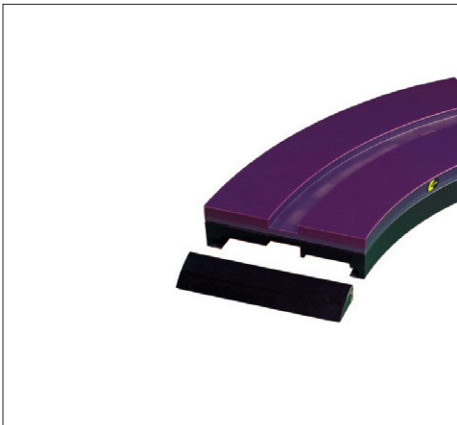

Number of Tracks	1
Width W	340 mm

Version C96	
15°	724.44.16
30°	724.44.31
45°	724.44.46
60°	724.44.61
75°	724.44.76
90°	724.44.01

More than 1 track on request.
 • For plastic chains: HDFM 1200 LF/SG.

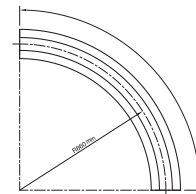

Radius
R = 860

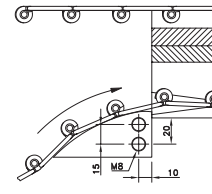

Return guide shoe

Magnetflex Combi-A Version LBP2

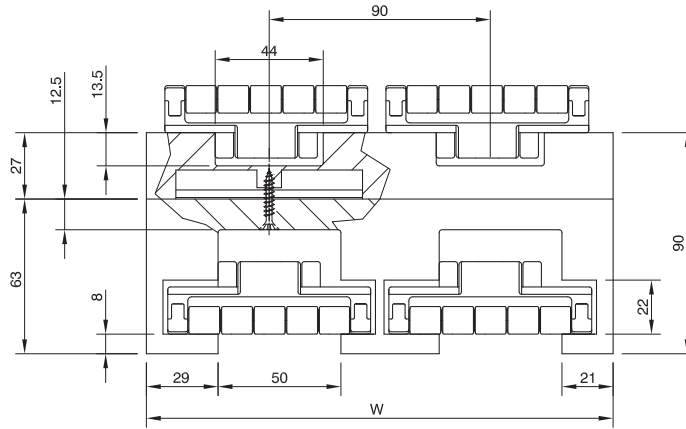
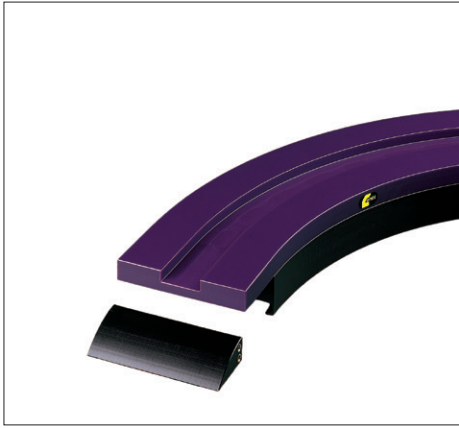

Number of Tracks	1	2	3	4	5	6
Width W	100 mm	190 mm	280 mm	370 mm	460 mm	550 mm

Version LBP2

15°	704.34.16	704.34.17	704.34.18	704.34.19	704.34.20	704.34.21
30°	704.34.31	704.34.32	704.34.33	704.34.34	704.34.35	704.34.36
45°	704.34.46	704.34.47	704.34.48	704.34.49	704.34.50	704.34.51
60°	704.34.61	704.34.62	704.34.63	704.34.64	704.34.65	704.34.66
75°	704.34.76	704.34.77	704.34.78	704.34.79	704.34.80	704.34.81
90°	704.34.01	704.34.02	704.34.03	704.34.04	704.34.05	704.34.06

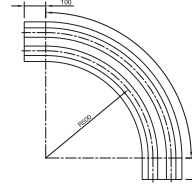

Radius

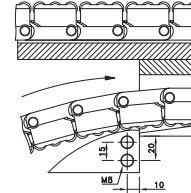

Return guide shoe

More than 6 tracks on request.

• For plastic chains: RHMD 325 LBP.

Magnetflex Combi-A Version LBP861

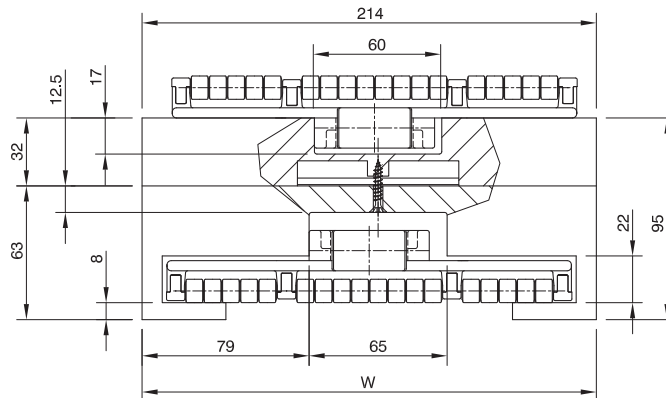

Number of Tracks	1
Width W	214 mm

Version LBP861

15°	724.47.16
30°	724.47.31
45°	724.47.46
60°	724.47.61
75°	724.47.76
90°	724.47.01

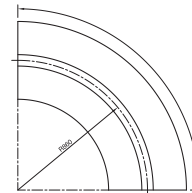

Radius

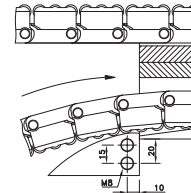

Return guide shoe

More than 1 track on request.

• For plastic chains: HDFM 750 LBP.

Magnetflex Combi-A Version LBP91

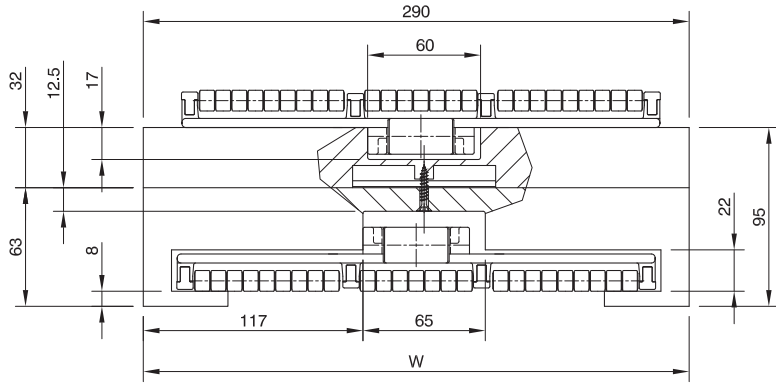

Number of Tracks	1
Width W	290 mm

Version LBP91	
15°	724.45.16
30°	724.45.31
45°	724.45.46
60°	724.45.61
75°	724.45.76
90°	724.45.01

More than 1 track on request.
 • For plastic chains: HDFM 1000 LBP.

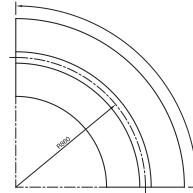

Radius

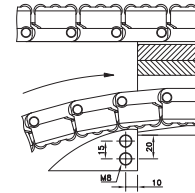

Return guide shoe

Magnetflex Combi-A Version LBP96

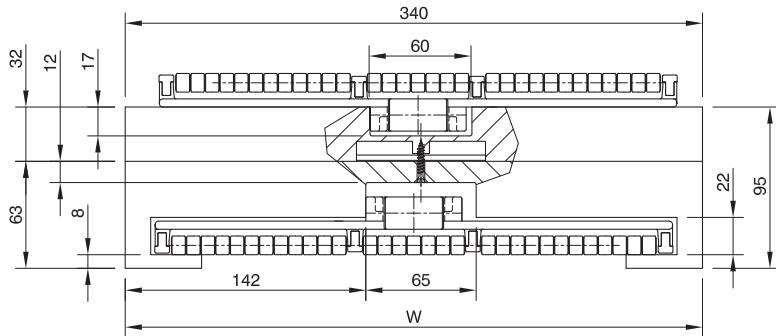
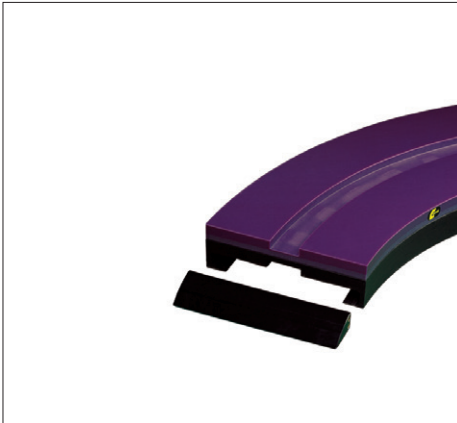

Number of Tracks	1
Width W	340 mm

Version LBP96	
15°	724.46.16
30°	724.46.31
45°	724.46.46
60°	724.46.61
75°	724.46.76
90°	724.46.01

More than 1 track on request.
 • For plastic chains: HDFM 1200 LBP.

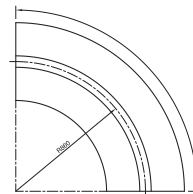

Radius

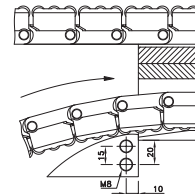

Return guide shoe

Magnetflex Combi-A Version CB6

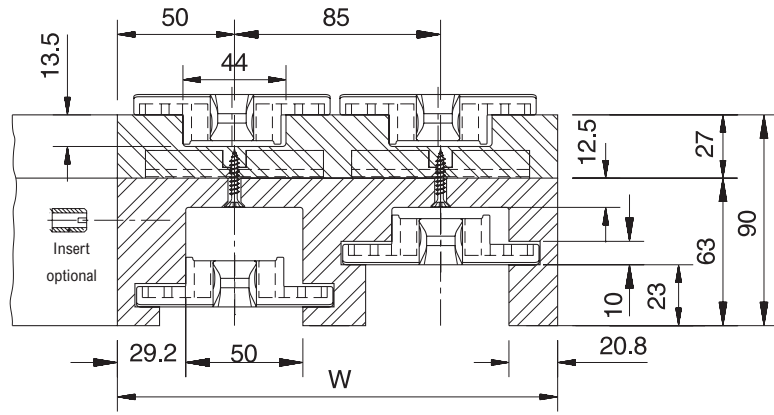

Number of Tracks	1	2	3	4	5	6
Width W	100 mm	185 mm	270 mm	355 mm	440 mm	525 mm
Version CB6						
15°	604.14.16	604.14.17	604.14.18	604.14.19	604.14.20	604.14.21
30°	604.14.31	604.14.32	604.14.33	604.14.34	604.14.35	604.14.36
45°	604.14.46	604.14.47	604.14.48	604.14.49	604.14.50	604.14.51
60°	604.14.61	604.14.62	604.14.63	604.14.64	604.14.65	604.14.66
75°	604.14.76	604.14.77	604.14.78	604.14.79	604.14.80	604.14.81
90°	604.14.01	604.14.02	604.14.03	604.14.04	604.14.05	604.14.06

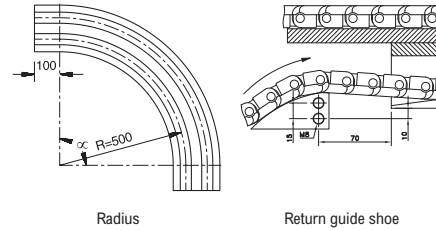

More than 6 tracks on request.

• For plastic chains: FGM 1050, FTM 1060, FGM 1040, FTM 1040.

Magnetflex Combi-X Version CXB6

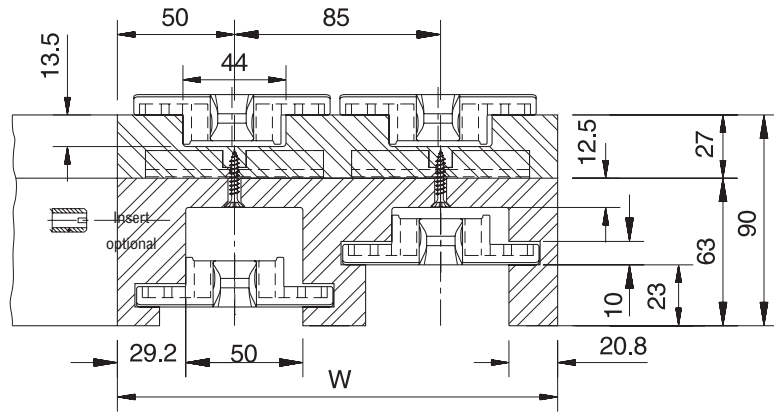
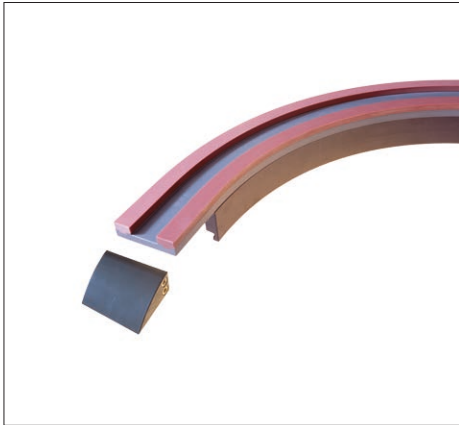

Number of Tracks	1	2	3	4	5	6
Width W	100 mm	185 mm	270 mm	355 mm	440 mm	525 mm
Version CXB6						
15°	604.41.16	604.41.17	604.41.18	604.41.19	604.41.20	604.41.21
30°	604.41.31	604.41.32	604.41.33	604.41.34	604.41.35	604.41.36
45°	604.41.46	604.41.47	604.41.48	604.41.49	604.41.50	604.41.51
60°	604.41.61	604.41.62	604.41.63	604.41.64	604.41.65	604.41.66
75°	604.41.76	604.41.77	604.41.78	604.41.79	604.41.80	604.41.81
90°	604.41.01	604.41.02	604.41.03	604.41.04	604.41.05	604.41.06

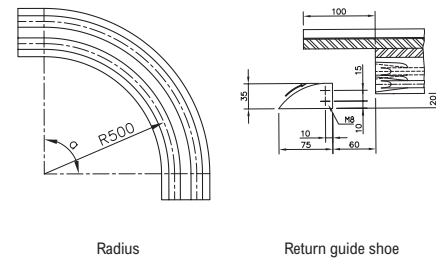

More than 6 tracks on request.

• For plastic chains: FGM 1050, FTM 1060, FGM 1040, FTM 1040.

Magnetflex Combi-A Version CC6

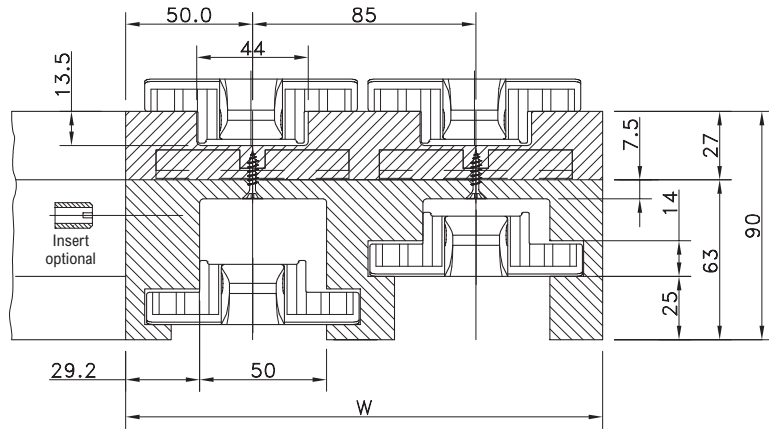

Number of Tracks	1	2	3	4	5	6
Width W	100 mm	185 mm	270 mm	355 mm	440 mm	525 mm
Version CC6						
15°	614.02.16	614.02.17	614.02.18	614.02.19	614.02.20	614.02.21
30°	614.02.31	614.02.32	614.02.33	614.02.34	614.02.35	614.02.36
45°	614.02.46	614.02.47	614.02.48	614.02.49	614.02.50	614.02.51
60°	614.02.61	614.02.62	614.02.63	614.02.64	614.02.65	614.02.66
75°	614.02.76	614.02.77	614.02.78	614.02.79	614.02.80	614.02.81
90°	614.02.01	614.02.02	614.02.03	614.02.04	614.02.05	614.02.06

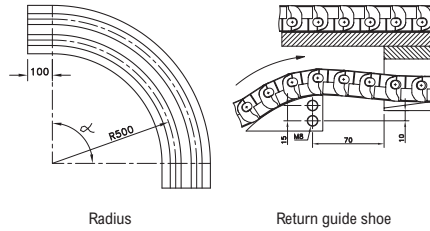

More than 6 tracks on request.
 • For plastic chains: FTM 1055 K330.

Magnetflex Combi-X Version CXC6

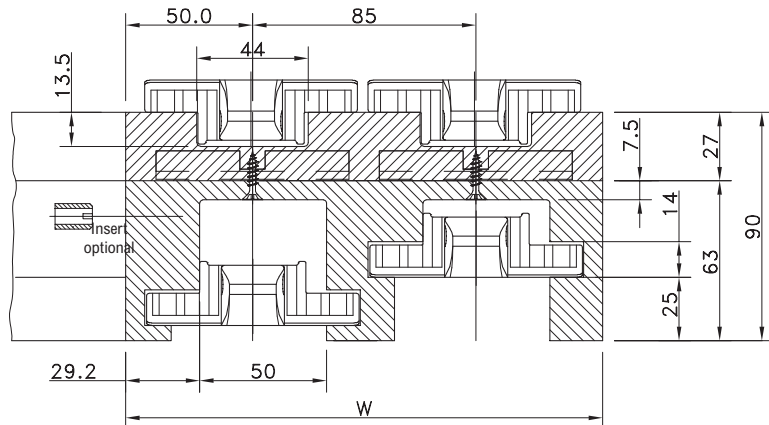

Number of Tracks	1	2	3	4	5	6
Width W	100 mm	185 mm	270 mm	355 mm	440 mm	525 mm
Version CXC6						
15°	614.10.16	614.10.17	614.10.18	614.10.19	614.10.20	614.10.21
30°	614.10.31	614.10.32	614.10.33	614.10.34	614.10.35	614.10.36
45°	614.10.46	614.10.47	614.10.48	614.10.49	614.10.50	614.10.51
60°	614.10.61	614.10.62	614.10.63	614.10.64	614.10.65	614.10.66
75°	614.10.76	614.10.77	614.10.78	614.10.79	614.10.80	614.10.81
90°	614.10.01	614.10.02	614.10.03	614.10.04	614.10.05	614.10.06

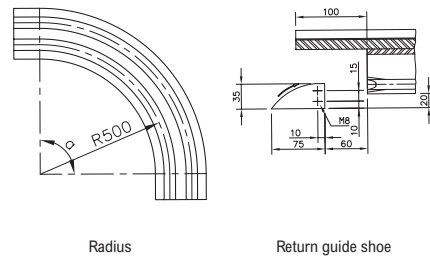

More than 6 tracks on request.
 • For plastic chains: FTM 1055 K330.

Magnetflex Combi-A Version CC21

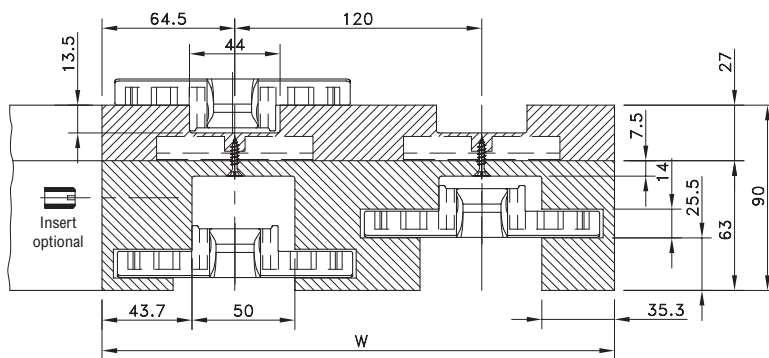
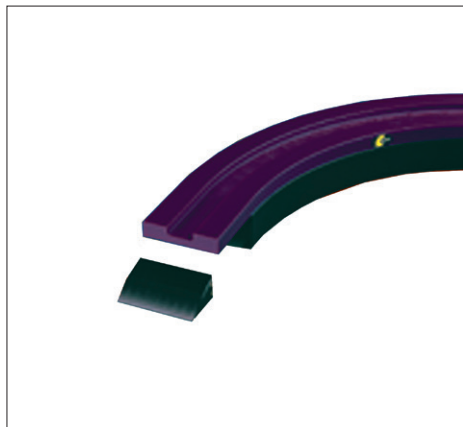

Number of Tracks	1	2	3	4
Width W	129 mm	249 mm	369 mm	489 mm

Version CC21

15°	614.08.16	614.08.17	614.08.18	614.08.19
30°	614.08.31	614.08.32	614.08.33	614.08.34
45°	614.08.46	614.08.47	614.08.48	614.08.49
60°	614.08.61	614.08.62	614.08.63	614.08.64
75°	614.08.76	614.08.77	614.08.78	614.08.79
90°	614.08.01	614.08.02	614.08.03	614.08.04

More than 4 tracks on request.

• For plastic chains: FTM 1055 K450.

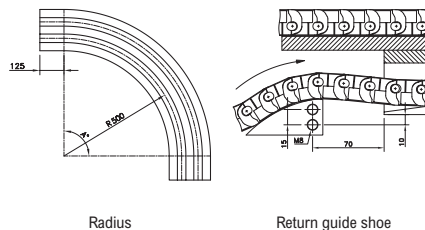

Radius

Return guide shoe

KTX for single hinge chains

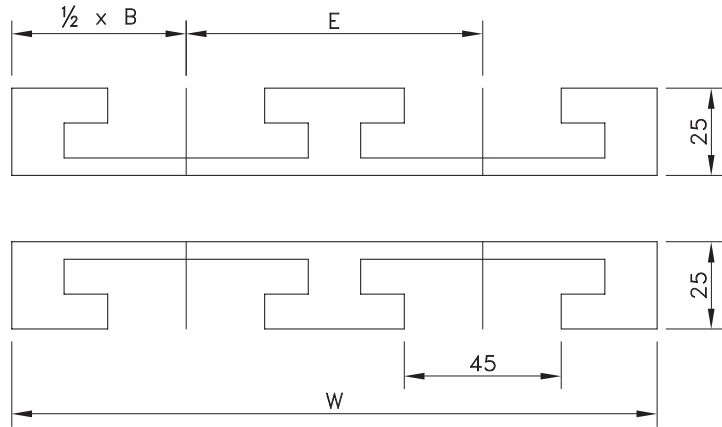
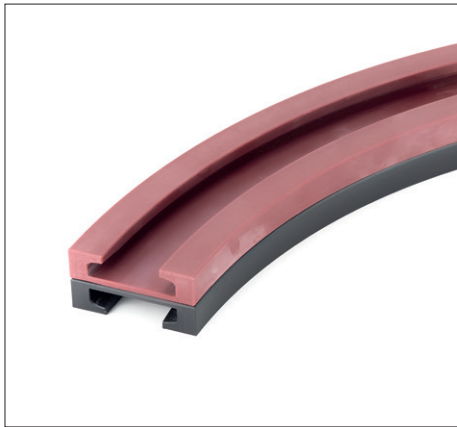

P. 17, 18, 25



P. 34,36,38,39, 43,44,50,52

Number of Tracks	1	2	3	Pitch	Basic Width	Radius
				E	M	R
				mm	mm	mm

Version KTX 013

Width W	100 mm	190 mm	280 mm	For 3.25" wide chains		
15°	LOKTX649933	LOKTX649943	LOKTX649953	90	100	500
30°	LOKTX649963	LOKTX649973	LOKTX649983			
45°	LOKTX649993	LOKTX650003	LOKTX650013			
60°	LOKTX650023	LOKTX650033	LOKTX650043			
75°	LOKTX650053	LOKTX650063	LOKTX650073			
90°	LOKTX650083	LOKTX650093	LOKTX650103			

Version KTX 018

Width W	125 mm	245 mm	365 mm	For 4.50" wide chains		
15°	LOKTX650113	LOKTX650123	LOKTX650133	120	125	610
30°	LOKTX650143	LOKTX650153	LOKTX650163			
45°	LOKTX650173	LOKTX650183	LOKTX650193			
60°	LOKTX650203	LOKTX650213	LOKTX650223			
75°	LOKTX650233	LOKTX650243	LOKTX650253			
90°	LOKTX650263	LOKTX650273	LOKTX650283			

Version KTU 013

Width W	100 mm	190 mm	280 mm	For 3.25" wide chains		
15°	787.02.77	787.0 8.24	787.08.25	90	100	500
30°	787.05.60	787.08.29	787.08.30			
45°	787.03.08	787.04.06	787.08.34			
60°	787.05.71	787.08.38	787.08.39			
75°	787.05.77	787.08.43	787.08.44			
90°	787.00.02	787.00.51	787.00.50			

Version KTU 018

Width W	125 mm	245 mm	365 mm	For 4.50" wide chains		
15°	787.08.49	787.08.50	787.08.51	120	125	610
30°	787.08.55	787.08.56	787.08.57			
45°	787.07.37	787.08.61	787.08.62			
60°	787.08.66	787.08.67	787.08.68			
75°	787.08.72	787.08.73	787.08.74			
90°	787.01.09	787.00.87	787.01.10			

Version KTU 030

Width W	200 mm	395 mm	590 mm	For 7.50" wide chains		
15°	787.08.80	787.08.81	787.08.82	195	200	610
30°	787.08.86	787.08.87	787.08.88			
45°	787.08.92	787.08.93	787.08.94			
60°	787.08.98	787.08.99	787.09.00			
75°	787.09.04	787.09.05	787.09.06			
90°	787.00.07	787.01.11	787.01.12			

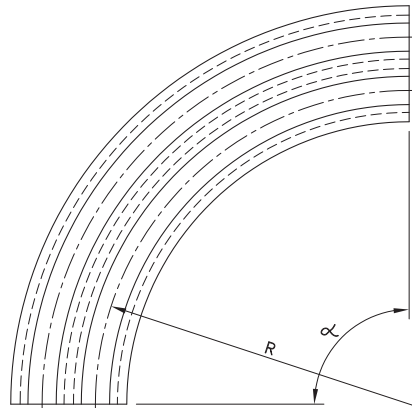

For steel chains:

- 8811 TAB
- 881 TAB
- 66 T 72 RM

For plastic chains:

- 880 TAB
- 880 TAB BO
- 879 TAB
- 879 TAB BO
- 880 TAB BOT
- 1050 TAB
- 1055 TAB

KTU for single hinge chains



The code nr. includes both upper and under part.

KTU 200 For Heavy Duty Chains

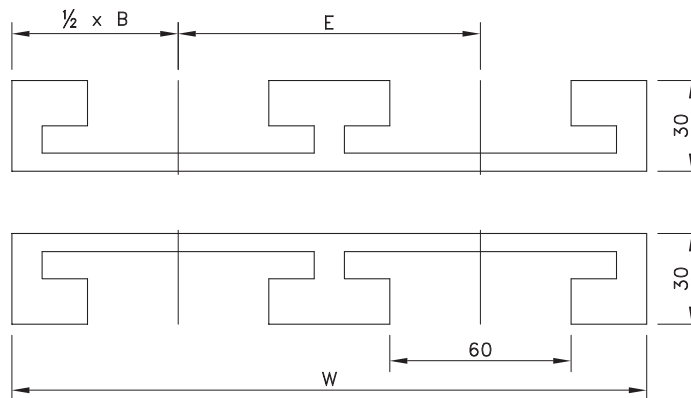

Number of Tracks	1	2	3	Pitch E	Basic Width M	Radius R
				mm	mm	mm

Version KTU 215

Width W	110 mm	210 mm	310 mm	For 3.25" and 3.75" wide		
15°	787.12.09	787.12.10	787.12.11	100	110	700
30°	787.12.15	787.12.16	787.12.17			
45°	787.12.21	787.12.22	787.12.23			
60°	787.12.27	787.12.28	787.12.29			
75°	787.12.33	787.12.34	787.12.35			
90°	787.00.05	787.12.39	787.12.40			

Version KTU 218

Width W	130 mm	250 mm	370 mm	For 4.50" wide chains		
15°	787.11.08	787.11.09	787.11.10	120	130	610
30°	787.11.14	787.11.15	787.11.16			
45°	787.04.69	787.11.20	787.11.21			
60°	787.04.07	787.11.25	787.11.26			
75°	787.11.30	787.11.31	787.11.32			
90°	787.02.80	787.07.80	787.11.36			

Version KTU 230

Width W	210 mm	405 mm	600 mm	For 7.50" wide chains		
15°	787.11.40	787.11.41	787.11.42	195	210	610
30°	787.11.46	787.11.47	787.11.48			
45°	787.04.68	787.11.52	787.11.53			
60°	787.11.57	787.11.58	787.11.59			
75°	787.11.63	787.11.64	787.11.65			
90°	787.00.54	787.11.69	787.11.70			

Version KTU 240

Width W	270 mm	530 mm	790 mm	For 10.00" wide chains		
15°	787.11.74	787.11.75	787.11.76	260	270	610
30°	787.11.80	787.11.81	787.11.82			
45°	787.11.86	787.11.87	787.11.88			
60°	787.11.92	787.11.93	787.11.94			
75°	787.11.98	787.11.99	787.12.00			
90°	787.00.06	787.03.26	787.12.04			

Version KTU 248

Width W	320 mm	630 mm	940 mm	For 12.00" wide chains *		
15°	787.12.44	787.12.45	787.12.46	310	320	610
30°	787.12.50	787.12.51	787.12.52			
45°	787.12.56	787.12.57	787.12.58			
60°	787.12.62	787.12.63	787.12.64			
75°	787.12.68	787.12.69	787.12.70			
90°	787.00.21	787.12.74	787.12.75			

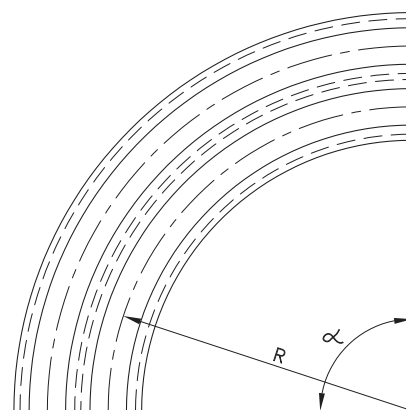

For plastic chains:

- 882 TAB
- 883 TAB
- HDF

* Not for LBP 1200 chains.
The code nr. includes both upper and under part.

KTU 300 For PlateTop Chains

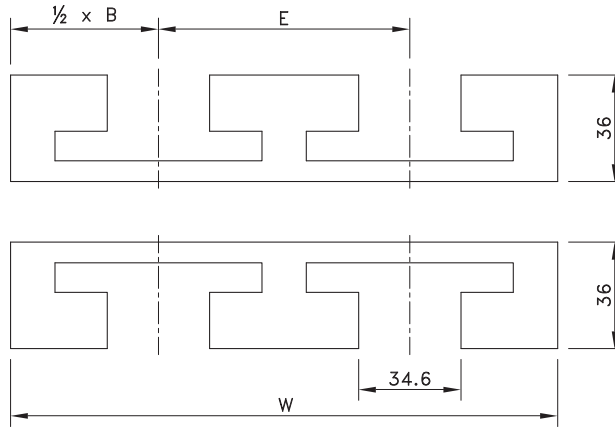

Number of Tracks	1	2	3	Pitch E	Basic Width B	Radius R
				mm	mm	mm

Version KTU 313

Width W	100 mm	190 mm	280 mm	For 3.25" wide chains		
15°	787.09.13	787.09.14	787.09.15	90	100	500
30°	787.09.19	787.09.20	787.09.21			
45°	787.09.25	787.09.26	787.09.27			
60°	787.09.31	787.09.32	787.09.33			
75°	787.09.37	787.09.38	787.09.39			
90°	787.01.13	787.01.14	787.01.15			

Version KTU 318

Width W	125 mm	245 mm	365 mm	For 4.50" wide chains		
15°	787.09.45	787.09.46	787.09.47	120	125	500
30°	787.09.51	787.09.52	787.09.53			
45°	787.07.50	787.09.57	787.09.58			
60°	787.09.62	787.09.63	787.09.64			
75°	787.09.68	787.09.69	787.09.70			
90°	787.01.16	787.01.17	787.01.18			

Version KTU 324

Width W	160 mm	320 mm	480 mm	For 6.00" wide chains		
15°	787.09.77	787.09.78	787.09.79	160	160	610
30°	787.09.83	787.09.84	787.09.85			
45°	787.09.89	787.09.90	787.09.91			
60°	787.09.95	787.09.96	787.09.97			
75°	787.10.01	787.10.02	787.10.03			
90°	787.01.19	787.01.20	787.01.21			

Version KTU 330

Width W	200 mm	395 mm	590 mm	For 7.50" wide chains		
15°	787.10.10	787.10.11	787.10.12	195	200	610
30°	787.10.16	787.10.17	787.10.18			
45°	787.10.22	787.10.23	787.10.24			
60°	787.10.28	787.10.29	787.10.30			
75°	787.10.34	787.10.35	787.10.36			
90°	787.01.22	787.01.23	787.01.24			

Version KTU 340

Width W	260 mm	520 mm	780 mm	For 10.00" wide chains		
15°	787.10.43	787.10.44	787.10.45	260	260	610
30°	787.10.49	787.10.50	787.10.51			
45°	787.04.70	787.10.55	787.10.56			
60°	787.10.60	787.10.61	787.10.62			
75°	787.10.66	787.10.67	787.10.68			
90°	787.01.25	787.01.26	787.01.27			

Version KTU 348

Width W	310 mm	620 mm	930 mm	For 12.00" wide chains		
15°	787.10.75	787.10.76	787.10.77	310	310	610
30°	787.10.81	787.10.82	787.10.83			
45°	787.10.87	787.10.88	787.10.89			
60°	787.10.93	787.10.94	787.10.95			
75°	787.10.99	787.11.00	787.11.01			
90°	787.01.28	787.01.29	787.01.30			

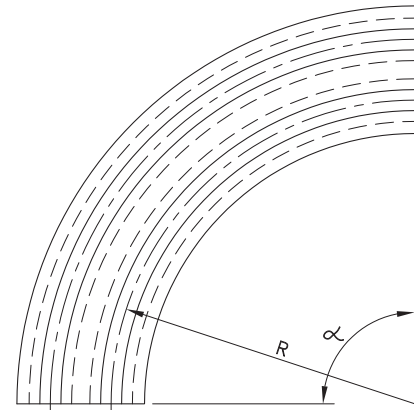

For plate top chains:

- 1873 TAB
- 1874 TAB
- 3873 TAB

The code nr. includes both upper and under part.

KTU 500 For Multiflex Chains

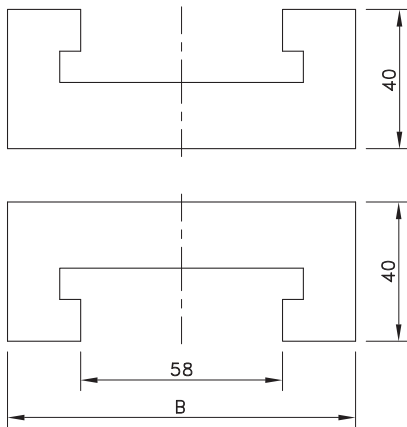

Number of Tracks	1	Basic Width
		B mm

Version KTU 508

Radius	250 mm	500 mm	For 1700 TAB K
15°	787.12.79	787.12.89	100
30°	787.12.80	787.04.35	
45°	787.12.81	787.12.90	
60°	787.12.82	787.12.91	
75°	787.12.83	787.12.92	
90°	787.03.31	787.01.81	

The code nr. includes both upper and under part.

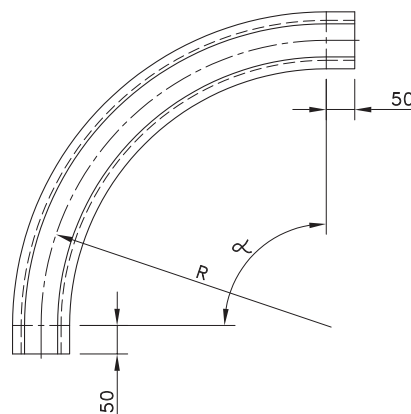

For plastic Multiflex chains:
• 1700 TAB K

KSU for single hinge chains

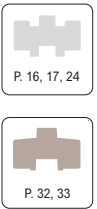
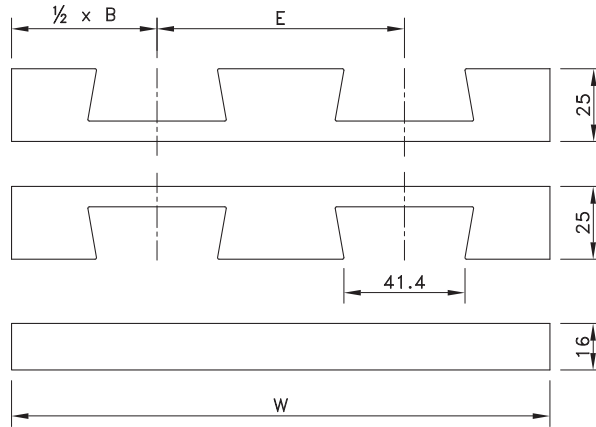

Number of Tracks	1	2	3	Pitch E	Basic Width B	Radius R
				mm	mm	mm

Version KSU 013

Width W	100 mm	190 mm	280 mm	For 3.25" wide chains		
15°	787.13.03	787.13.04	787.13.05	90	100	500
30°	787.02.50	787.13.09	787.13.10			
45°	787.02.51	787.13.14	787.13.15			
60°	787.13.19	787.13.20	787.13.21			
75°	787.13.25	787.13.26	787.13.27			
90°	787.00.85	787.00.97	787.00.75			

Version KSU 018

Width W	125 mm	245 mm	365 mm	For 4.50" wide chains		
15°	787.13.33	787.13.34	787.13.35	120	125	610
30°	787.13.39	787.13.40	787.13.41			
45°	787.13.45	787.13.46	787.13.47			
60°	787.13.51	787.13.52	787.13.53			
75°	787.13.57	787.13.58	787.13.59			
90°	787.00.17	787.00.98	787.00.99			

Version KSU 030

Width W	200 mm	395 mm	590 mm	For 7.50" wide chains		
15°	787.13.66	787.13.67	787.13.68	195	200	610
30°	787.13.72	787.13.73	787.13.74			
45°	787.13.78	787.13.79	787.13.80			
60°	787.13.84	787.13.85	787.13.86			
75°	787.13.90	787.13.91	787.13.92			
90°	787.00.94	787.01.00	787.01.01			

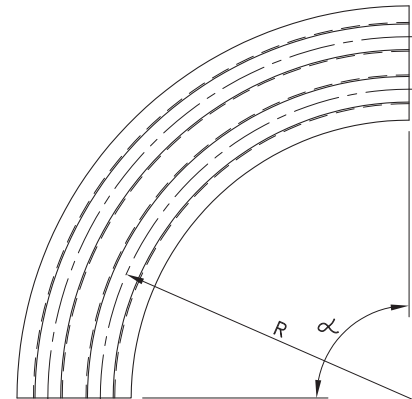

For steel chains:

- 8811
- 881
- 66 B 72 RM

For plastic chains:

- 880
- 879

The code nr. includes both upper and under part.

KSU for Heavy Duty chains

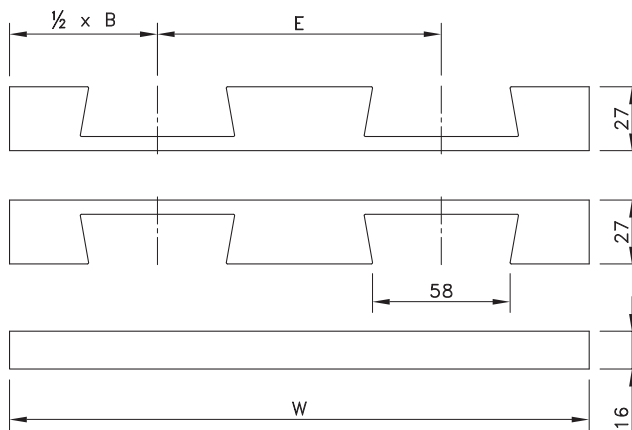

Number of Tracks	1	2	3	Pitch E	Basic Width B	Radius R
				mm	mm	mm

Version KSU 218

Width W	125 mm	245 mm	365 mm	For 4.50" wide chains		
15°	787.13.99	787.14.00	787.14.01	120	125	610
30°	787.14.05	787.14.06	787.14.07			
45°	787.14.11	787.14.12	787.14.13			
60°	787.14.17	787.14.18	787.14.19			
75°	787.14.23	787.14.24	787.14.25			
90°	787.00.95	787.01.02	787.01.03			

Version KSU 230

Width W	200 mm	395 mm	590 mm	For 7.50" wide chains		
15°	787.14.32	787.14.33	787.14.34	195	200	610
30°	787.14.38	787.14.39	787.14.40			
45°	787.14.44	787.14.45	787.14.46			
60°	787.14.50	787.14.51	787.14.52			
75°	787.14.56	787.14.57	787.14.58			
90°	787.00.96	787.01.04	787.01.05			

Version KSU 240

Width W	265 mm	525 mm	785 mm	For 10.00" wide chains		
15°	787.14.65	787.14.66	787.14.67	260	265	610
30°	787.14.71	787.14.72	787.14.73			
45°	787.14.77	787.14.78	787.14.79			
60°	787.14.83	787.14.84	787.14.85			
75°	787.14.89	787.14.90	787.14.91			
90°	787.01.06	787.01.07	787.01.08			

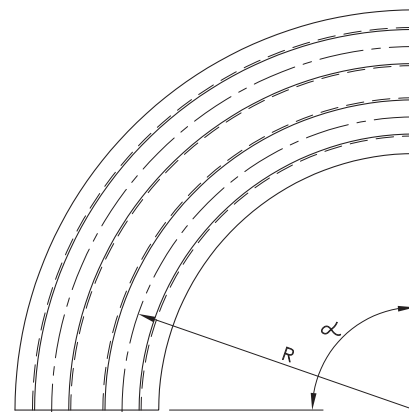

For plastic chains:
• 882

The code nr. includes both upper and under part.

STU for Tab Chains



Type	Code Number	Basic Width B	For Chain Types
Version STU			
STU 013	787.90.09	100	<ul style="list-style-type: none"> • 8811 TAB • 881 TAB • 880 TAB/BO/BOT • 879 TAB/BO • RH/RHD • 1050/1055 TAB
STU 018	787.90.04	130	
Version STU 200			
STU 218	787.90.17	130	<ul style="list-style-type: none"> • 882 TAB • 883 TAB • HDF
STU 230	787.90.05	210	
STU 240	787.90.06	270	
STU 248	787.90.07	320	
Version STU 300			
STU 313	787.45.27	100	<ul style="list-style-type: none"> • 1873 TAB • 1874 TAB • 3873 TAB
STU 318	787.47.56	125	
STU 324	787.47.97	160	
STU 330	787.46.85	200	
STU 340	787.48.04	260	
STU 348	787.90.16	310	
Version STU 500			
STU 508	787.40.74	100	<ul style="list-style-type: none"> • 1700 TAB K • 1713 TAB K
STU 515	787.90.11	110	
STU 540	787.90.20	270	

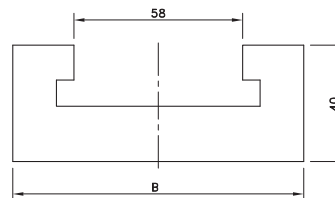
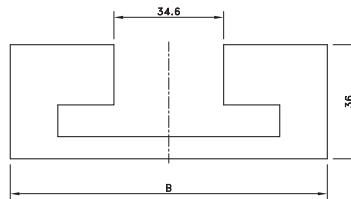
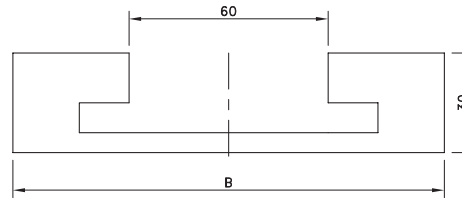
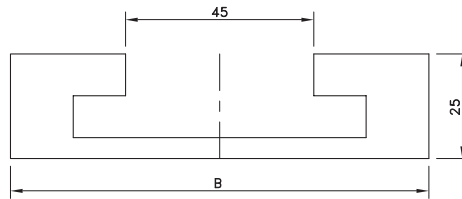

SSU for Bevel Chains



Type	Code Number	Basic Width B	For Chain Types
Version SSU			
SSU 013	787.90.02	100	• 8811 • 881
SSU 018	787.90.18	130	• 880 • 879
Return Plates			
SSU 013 P	787.90.03	100	• 8811 • 881
SSU 018 P	787.90.19	130	• 880 • 879

All straight tracks have a standard length of 2 meters; other lengths upon request.

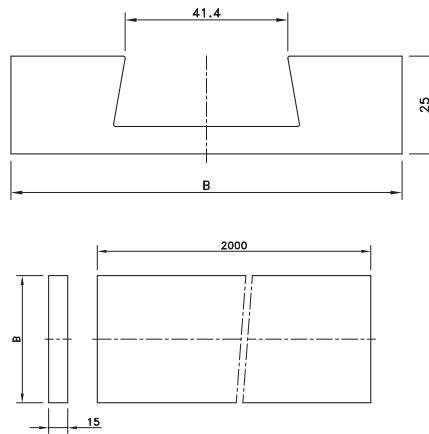

MatTop Chains

Solid Top Chains

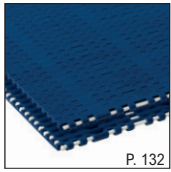

P. 132
390

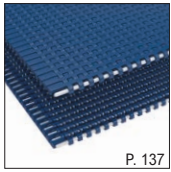

P. 137
595

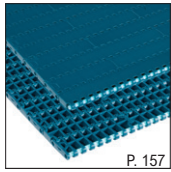

P. 157
1000

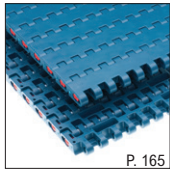

P. 165
1005

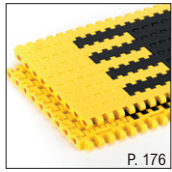

P. 176
1025

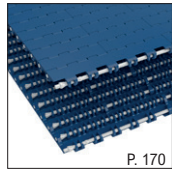

P. 170
1010

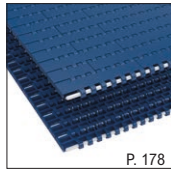

P. 178
1090

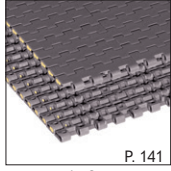

P. 141
1505

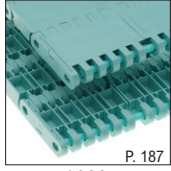

P. 187
2000

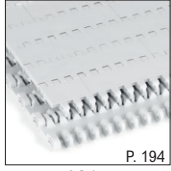

P. 194
2015

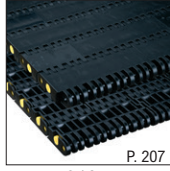

P. 207
3125

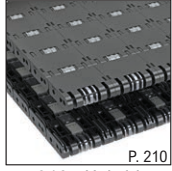

P. 210
3125 Hybrid

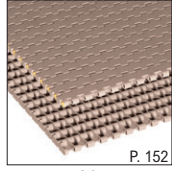

P. 152
5935

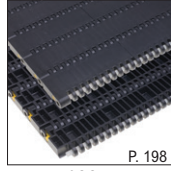

P. 198
6995

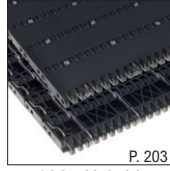

P. 203
6995 Hybrid

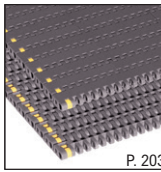

P. 203
6995 ESD4

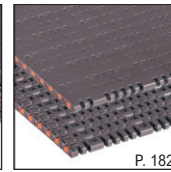

P. 182
7705

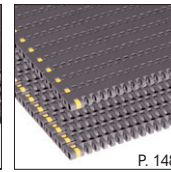

P. 148
8505

Perforated Top Chains

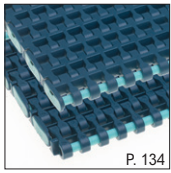

P. 134
500

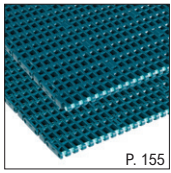

P. 155
1000

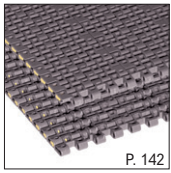

P. 142
1506

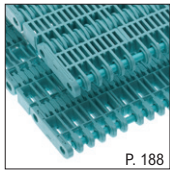

P. 188
2000

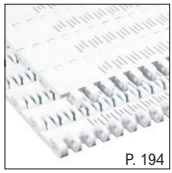

P. 194
2016

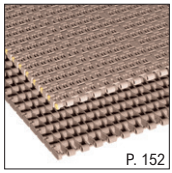

P. 152
5936



P. 211
3125 Hybrid

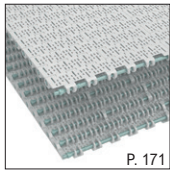

P. 171
1016

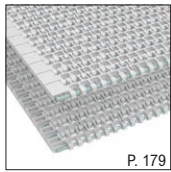

P. 179
1096

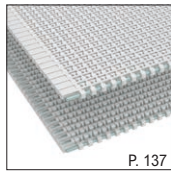

P. 137
596

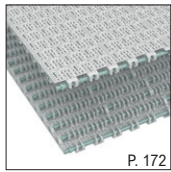

P. 172
1018

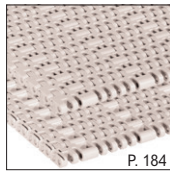

P. 184
7708

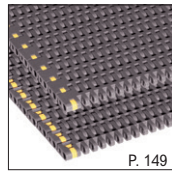

P. 149
8506

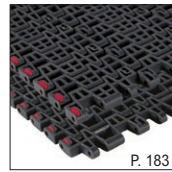

P. 183
7748

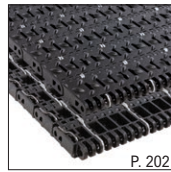

P. 202
6992 Hybrid

RubberTop Chains

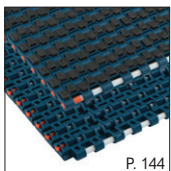

P. 144
1505

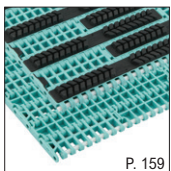

P. 159
1000

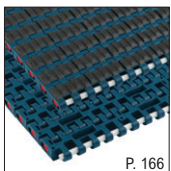

P. 166
1005



P. 208
3125 RT



P. 208
3185 RT

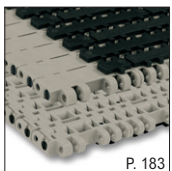

P. 183
7705

MatTop Chains

Raised Rib Chains

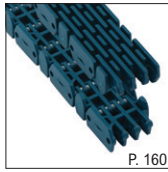

1000

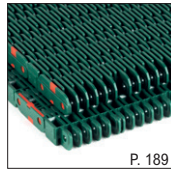

2000

P. 160

P. 189

Vacuum Holes Chains

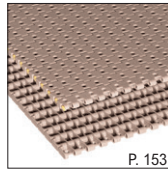

5935

P. 153

Low back Pressure Chains

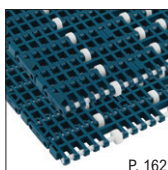

1000

P. 162

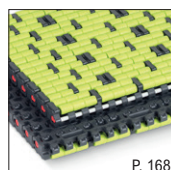

1005XLBP

P. 168

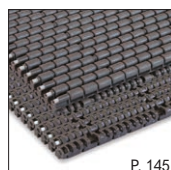

1553

P. 145

Perforated TopSide-Flexing

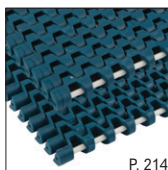

505

P. 214

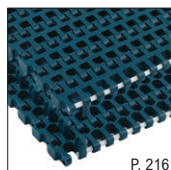

1255

P. 216

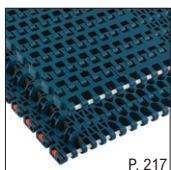

1265

P. 217

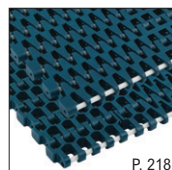

1275

P. 218

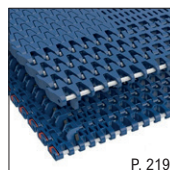

1285

P. 219

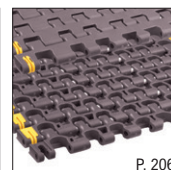

7956

P. 206

Perforated Nub Top

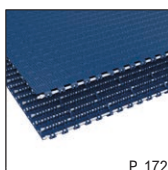

1011

P. 172

Textured Top

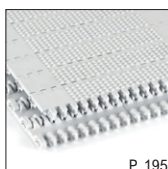

Textured Top 2011

P. 195

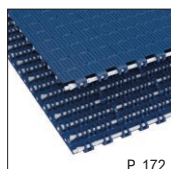

1011

P. 172

Safety Top



1029

P. 176

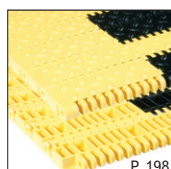

6999

P. 198



6999 ESD4

P. 207

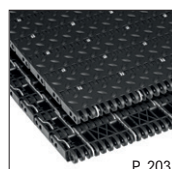

6999 HYB

P. 203

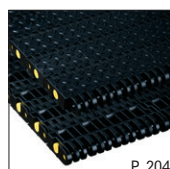

3129

P. 204

Con un'ampia varietà di versioni e materiali MatTop, Rexnord offre una soluzione di trasporto per praticamente qualsiasi applicazione, specialmente in combinazione con l'ampia gamma di catene TableTop. Il marchio MCC ha fissato lo standard di riferimento per i nastri trasportatori nell'industria delle bevande e adesso la facilità di pulizia e gli accessori specifici rendono molte serie Rexnord MatTop ideali anche per l'industria alimentare. Anche in molti altri settori industriali, come quelli della produzione di contenitori, prodotti farmaceutici e componenti di automobili, le linee sono equipaggiate con catene MatTop Rexnord. Le catene MatTop sono affidabili e sfruttano l'enorme esperienza accumulata da Rexnord nel settore della tecnologia di trasporto su catene.

La struttura dei nastri e delle ruote di traino costituisce una combinazione perfetta che soddisfa gli elevati standard per l'innesto dei denti e dei nastri, il rilascio dei nastri dalle ruote di traino e l'allungamento consentito. Le catene MatTop Rexnord e MCC sono note anche per il loro sistema intelligente di ritenzione dei perni, che ne rendono molto facile l'installazione e la manutenzione.

Catene MatTop

La gamma di catene MatTop varia dalle versioni curvilinee con passo piccolo da ½ pollice fino alle soluzioni per carichi pesanti a corsa rettilinea con passo da 2½ pollici. Le varie serie vengono offerte in numerose variazioni, per soddisfare qualsiasi applicazione:

Superficie piena/superficie chiusa

Un'interfaccia completamente chiusa viene utilizzata qualora i prodotti richiedano il supporto massimo, considerata la loro delicatezza o instabilità, e se le particelle piccole, come ad esempio vetri rotti, bulloni e dadi, ossa o il prodotto stesso, potrebbero impigliarsi nella superficie del nastro, con possibilità di danneggiare o far incastrare il prodotto o il nastro.

Superficie perforata/superficie aperta

Una superficie ad area aperta viene utilizzata per consentire il flusso di acqua o aria attraverso il nastro e per rimuovere i materiali di scarto, facendo in modo che la superficie di contatto tra il nastro e i prodotti trasportati resti pulita. Lo sporco viene lavato via mediante un regolare programma di pulizia. L'area aperta varia a seconda del tipo di nastro.

Raised Rib

I nastri Raised Rib e i pettini di trasferimento sono appositamente studiati per il trasporto di prodotti (instabili) e il trasferimento su o da un nastro o una catena. I pettini di trasferimento si inseriscono all'interno e sotto la superficie delle nervature del nastro. I pettini di trasferimento sono disponibili in varie misure: le versioni più corte sono normalmente usate in caso di rischio di rottura del vetro.

Vacuum

I trasportatori Vacuum sono principalmente utilizzati per la produzione o la movimentazione di lattine vuote negli stabilimenti di produzione di bevande. I piccoli fori presenti nei nastri SUPERFICIE CHIUSA consentono di movimentare le lattine vuote mediante un vuoto sotto il nastro.

Superficie gommata/Supergrip

Sui trasportatori inclinati o in discesa, i pacchetti e le cassette possono essere movimentati con delicatezza utilizzando superfici gommate, stampate sopra un modulo appositamente preparato utilizzando una speciale tecnologia di stampaggio o a 2 componenti, garantendo un fissaggio sicuro al 100%. I nastri modulari Rubber Top possono essere utilizzati con inclinazioni fino a 20 gradi, a seconda della forma del pacchetto e del materiale.

Accumulo (LBP)

Per la movimentazione di prodotti accumulati (casce di cartone, pacchetti sigillati, cassette con base piatta, pneumatici, ecc...), i nastri LBP sono la scelta ideale. Le catene MatTop LBP1005 sono consigliate per i pacchetti sigillati senza base solida (cartone) e piccoli pacchetti, mentre le catene MatTop LBP7703 sono la scelta migliore per le casce (cartone), i pacchetti sigillati con fondo in cartone e i prodotti più grandi. Entrambe le versioni garantiscono una protezione ottimale dei prodotti e bassa rumorosità.

Nastri curvilinei

Questa serie di nastri offre una soluzione per praticamente qualsiasi applicazione curva.

Larghezze espresse con il sistema metrico decimale e con quello anglosassone

La maggior parte dei nastri è disponibile con larghezze espresse sia con il sistema metrico decimale che con quello anglosassone. Le larghezze espresse con il sistema metrico sono diventate standard nel settore delle bevande (Europa), adottando il passo standard da 85 mm tra le diverse vie di catene a tapparella in acciaio. Questo consente un elevato livello di standardizzazione tra la struttura dei nastri TableTop e MatTop. Le larghezze espresse con il sistema di misurazione anglosassone, utilizzate principalmente per il mercato del nord America, sono standard in numerose applicazioni al di fuori dell'industria delle bevande (Europa).

Sistema di guida Positrack

In numerose serie MatTop, Rexnord offre guide Positrack o Tab. Questo sistema consiste in due guide poste sotto il nastro, che consentono di guidarlo facilmente nel trasportatore. Il sistema Positrack offre dei vantaggi nel caso in cui vengano applicate delle forze laterali, come ad esempio nel caso dei trasferimenti laterali dei contenitori e dei prodotti dell'industria delle bevande. Il sistema trattiene il nastro sul telaio del trasportatore rendendo superflua l'aggiunta di altre guide di scorrimento laterali. Di solito le guide si trovano su un solo lato (doppio Positrack), consentendo l'espansione del nastro senza interferire con l'avanzamento preciso del nastro.

Sistema di trasferimento dinamico (DTS/FreeFlow)

L'opzione DTS® consente di costruire trasferimenti a 90 gradi a spostamento automatico sui quali nessun prodotto resta indietro, evitando l'utilizzo di piastre libere. Un nastro DTS o FreeFlow stretto viene spesso utilizzato accanto al nastro trasportatore principale. Grazie al movimento costante del nastro sotto ai prodotti, la pressione tra i prodotti e di conseguenza il rumore e il danneggiamento dei prodotti vengono ridotti al minimo rispetto ai trasferimenti con piastre morte. Questo sistema è disponibile nelle serie 1500, 8500, 1000, 1005 e 7700.

Facchini e sponde

In numerose serie è possibile selezionare i facchini e le sponde laterali. In considerazione della grande varietà delle possibilità di posizionamento di questi accessori, i nastri non hanno codici fissi. Nella pagina del prodotto è disponibile una tabella in cui vengono spiegate le possibilità di utilizzo. Vengono forniti degli esempi per creare una descrizione relativa alla configurazione del prodotto desiderata.

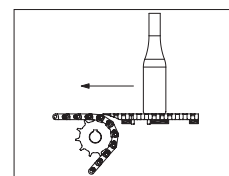
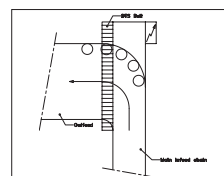
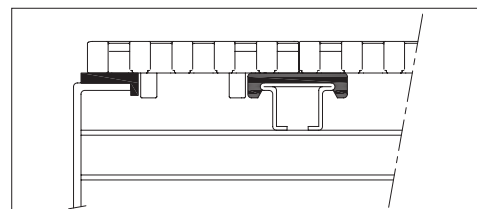

Application

Straight Running Belt Serie		Small Products (Packs)	Glass handling	PET handling	Can handling	Pack handling	Pack accumulation	Pack incline conveyors	Pasteurizer, warmer, cooler	Accumulation Tables	Crates, bread tins	Direct food contact	Blancher, cooker, cooler	Loose food incline conveyors	Cutting	Automotive
Type	Pitch															
390	8mm															
500	1/2"															
590	1/2"															
1500	15 mm															
8500	3/4"															
5930	3/4"															
1000	1"															
1005	1"															
1010	1"															
1090	1"															
7700	1"															
2000	2"															
2010	2"															
6990	2 1/4"															
2500	2 1/2"															
3120	3"															

Application

SideFlexing Belt Types		Small packages	Standard packages	180-Degree conveyors	High-speed conveyors	Small radius	Crates, bread tins	Incline conveyors	Direct food contact
Type	Pitch								
505	1/2"								
1255	1 1/4"								
1265	1 1/4"								
1275	1 1/4"								
1285	1 1/4"								
7956	1 1/4"								

Application

Material	Mass handling	Inliner standard	Inliner / high-speed / PET	Abrasive wet	Abrasive dry	Static electricity sensitive (dry)	Chemicals, strong cleaning agents	Direct food contact (FDA approved)	Cutting	High temperatures	Freezing	General conveying food industry	Automotive
LF													
XLG													
PSX													
BWX													
DKA													
AS													
XP/HT													
WSM*													
WHT*													
WLT*													
BSM/BYSM													
Dry-PT for PET													
HTX													
FRPLUS													

* For different colours of similar materials (e.g. SMB, BHT, etc.) the same recommendations apply. Not all materials are available in each belt series, but for specific applications the best materials are chosen.*) For individual application advice consult your local technical support representative.

Optional Best choice

Rexnord sviluppa costantemente catene e componenti per nastri trasportatori orientati a soluzioni innovative per rispondere alle crescenti esigenze di prestazione in termini di velocità e flusso di massa nei settori imbottigliamento e alimentare. La nostra Catena Rexnord® Serie 390 MatTop® fornisce un design ottimizzato per nastri di trasferimento stretti ("lama di coltello").

Inserimento catena-pignone:

- Gira su pignoni a trasmissione positiva, inclusi fori perno rotondi
- Le posizioni fisse del pignone garantiscono un inserimento ottimale e riducono il tempo d'installazione
- Il design della catena e dei denti del pignone garantisce un inserimento ottimale catena-pignone

Questo evita che la catena possa saltare sul dente quando si applica un carico leggero o pesante in caso di alta o bassa tensione della catena attorno al pignone.

Una catena con le migliori prestazioni del settore

La catena Rexnord 395 MatTop è progettata per offrire la più alta affidabilità e durabilità nelle applicazioni più critiche. Questo si ottiene con una combinazione di capacità di carico elevata, rigidità elevata e inserimento ottimale catena-pignone, anche quando è presente una controtensione bassa.



Sistema trasportatore dotato di Catena KleanTop Rexnord Serie 395.

Informazioni sul prodotto

- Robustezza straordinaria di 500 lbs/ft (7300 N/m)
- Larghezza imperiale con incrementi di 2 pollici (50,8 mm) e larghezza metrica con incrementi di 3,3 pollici (85 mm)
- Adatta per velocità fino a 164 ft/min (50 m/min)
- Sistema di ritenzione del perno semplice ma affidabile
- Elevata rigidità
- Materiali approvati per il contatto diretto con gli alimenti • Adatto per barra di pressione da 6 mm



Sistema trasportatore dotato di Catena KleanTop Rexnord Serie 395.

FlatTop 395

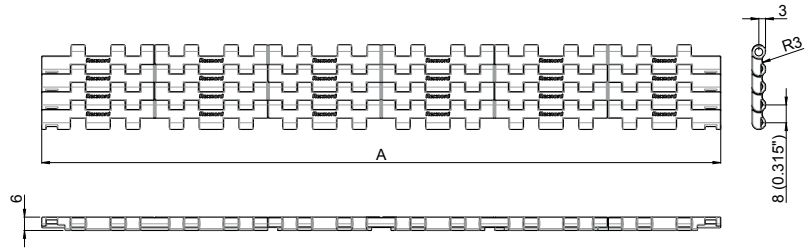
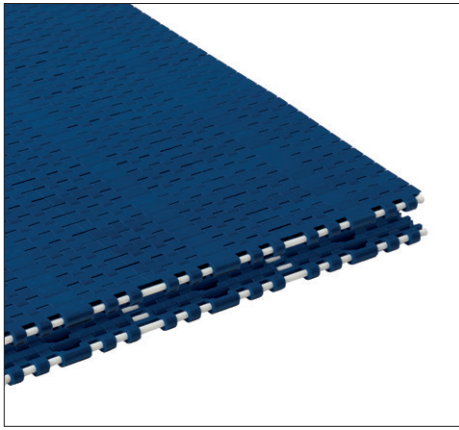

Rexnord 390 Series MatTop Chain Material (Imperial) Overview

Chain Type	Material	Standard Pin Material	Working Load (max)		Backflex Radius (min)	Temperature Range °C	
			lbs/ft / N/m	lbs/ft / kg/m		Dry	Wet
SMB395-XXIN	SMB (blue)	PBT	500 / 7300	1.2 / 5.7	0.2 / 3.0	4 to 80 / 4 to 65	
WSM395-XXIN	WSM (white)	PBT	500 / 7300	1.2 / 5.7	0.2 / 3.0		
HP395-XXIN	HP (grey)	PBT	500 / 7300	1.2 / 5.7	0.2 / 3.0		
PSX395-XXIN	PSX (grey)	PBT	500 / 7300	1.2 / 5.7	0.2 / 3.0		

General information:

- The Rexnord 395 MatTop Chain is offered in flat top surface execution
- (A) Nominal standard width of the (imperial) Rexnord 395 MatTop Chain is 6 IN and available with increments of 2 IN up to 120 IN

Rexnord 390 Series MatTop Chain Material (Metric) Overview

Chain Type	Material	Standard Pin Material	Working Load (max)		Backflex Radius (min)	Temperature Range °C	
			lbs/ft / N/m	lbs/ft / kg/m		Dry	Wet
XLG395-XXMM	XLG (blue)	PBT	500 / 7300	1.16 / 5.7	0.2 / 3.0	4 to 80 / 4 to 65	
PSX395-XXMM	PSX (grey)	PBT	500 / 7300	1.16 / 5.7	0.2 / 3.0		

General information:

- The Rexnord 395 MatTop Chain is offered in flat top surface execution
- (A) Nominal standard width of the (metric) Rexnord 395 MatTop Chain is 255 mm and available with increments of 85 mm up to 3600 mm

Number of Teeth	Pitch Diameter		Outside Diameter		Bore Diameter							
					Round				Square			
	in	mm	in	mm	in		mm		in		mm	
					min	max	min	max	min	max	min	max
KU 390 Series Sprocket												
24	2.4	61	2.4	63	3/4	1	20	30	1	1	25	30
32	3.2	83	3.2	83	3/4	1.5	20	30	1	1.5	25	40
36	3.6	92	3.6	93	3/4	1.5	20	40	1	1.5	25	40

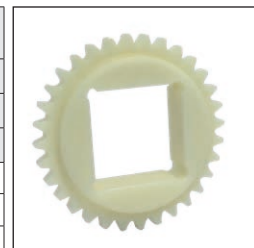

Rexnord KU390-32T 40MM S PA

Il nastro Serie 500 con passo da ½ pollice offre il passo più piccolo disponibile sul mercato. Questo passo rende il nastro altamente idoneo per la movimentazione di prodotti piccoli o instabili per i quali sono necessari piccoli trasferimenti in linea, ad esempio i trasportatori di entrata, come ad esempio quelli delle apparecchiature di imballaggio e produzione di lattine.

Di serie, i nastri vengono forniti in acetilica a basso attrito.

Caratteristiche

- Movimentazione perfetta dei prodotti grazie al passo estremamente ridotto che garantisce un funzionamento senza problemi e acetilica a basso attrito.
- Il passo ridotto da 12,7 mm riduce l'azione cordale e consente l'utilizzo di piastre di dimensioni ridotte o libere nei trasferimenti in linea.
- Bordi esterni arrotondati per un miglioramento dei trasferimenti laterali e migliore movimentazione dei prodotti.
- Il sistema di ritenzione dei perni con clips consente l'agevole accesso ai perni per le operazioni di installazione e manutenzione.



Trasportatore con nastro 500

Programma

500	Area aperta al 16%; garantisce il flusso d'acqua e aria ottimale e consente il passaggio dello sporco e di mantenere una superficie di contatto pulita tra i prodotti e il nastro; ideale la produzione e il trattamento di lattine
Fsuperficie Aperta	
Positrack	Piccole guide su un lato o su entrambi i lati del nastro, per garantire la precisione elevata del nastro anche su trasportatori lunghi e nei trasferimenti laterali. Il Positrack è consigliato anche nelle versioni con nastro a guida singola largo 85 mm



Trasportatore Con Nastro 500

Flush Grid 500

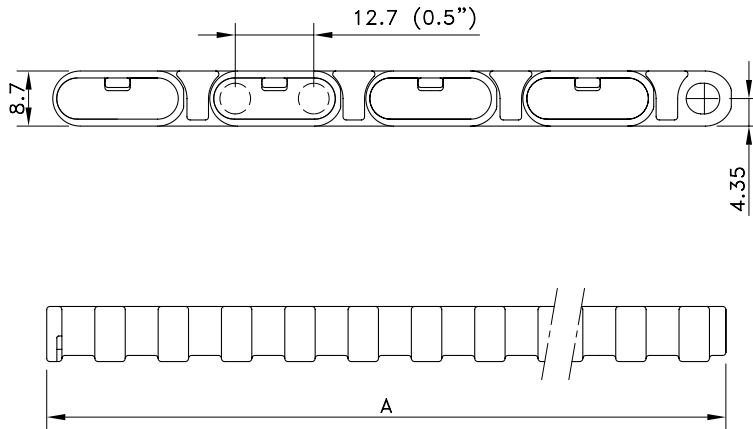
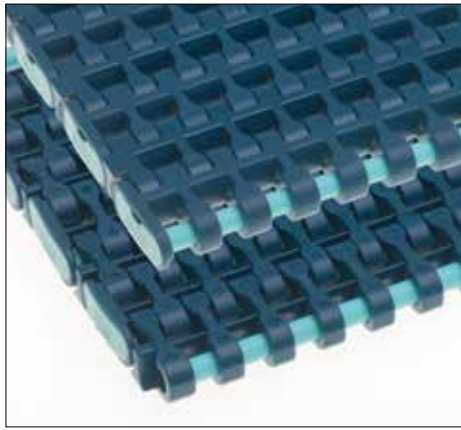

Assembly	Belt Type	Code Number*	Temperature range °C		Working Load (max) N/m (21°C)	Weight kg/m ²	Backflex Radius (min.) mm
			Dry	Wet			
XLG-Acetal With Polypropylene Pins							
STANDARD	FG 500 XLG	857.40.xx	4 to 80	4 to 65	13000	6.00	8
POSITRACK LEFT	FGP 500 XLG	874.05.xx					
POSITRACK RIGHT	FGP 500 XLG	874.06.xx					
POSITRACK TWO SIDES	FGP 500 XLG	874.04.xx					

* In code numbers xx corresponds with the belt width (A), starting with 10 for 85 mm, 11 for 170 mm and so on in steps of 85 mm. See page 208 for all code numbers. Cut to width options upon request.

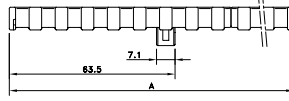
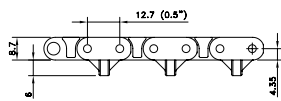

Left: Flush Grid 500 Belt With Positrack
Right: Positrack

Split Sprockets

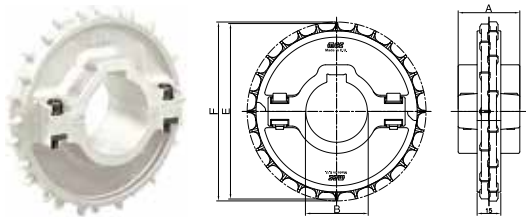

Classic Sprockets

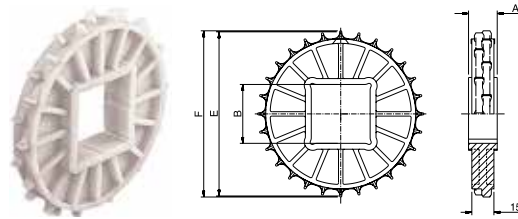

Sprocket Type	Code Number	Number of Teeth	Bore	Pitch Diameter E	Outside Diameter F	Hub Width A
			B			
			mm/inch	mm	mm	mm
Round Bores						
NS500-28T_30MM_1KW_PA	10302795	28	30 mm	113.4	113.4	39
NS500-28T_40MM_1KW_PA	10148194	28	40 mm			
NS500-28T_1-1/2IN_1KW_PA	10148196	28	1.5"			
Square bores						
NS500-28T_40MM_S_PA	10148195	28	40 mm	113.4	113.4	39
NS500-28T_1-1/2IN_S_PA	10328184	28	1.5"			
Classic sprockets						
Round Bores						
N500-16T_25MM_2KW_PA	10148170	16	25 mm	65.2	65.2	20
N500-16T_30MM_2KW_PA	10334318	16	30 mm			
N500-28T_25MM_2KW_PA	10148166	28	25 mm	113.4	113.4	
N500-28T_30MM_2KW_PA	10148167	28	30 mm			
N500-28T_40MM_2KW_PA	10148165	28	40 mm			
N500-28T_1-1/2IN_2KW_PA	10148169	28	1.5"			
N500-38T_40MM_2KW_PA	10148164	38	40 mm	153.8	153.1	
Square Bores						
N500-28T_40MM_S_PA	10148168	28	40 mm	113.4	113.4	20
N500-28T_60MM_S_PA	10334323	28	60 mm			

Le aziende di trasformazione di prodotti alimentari richiedono dei sistemi di trasporto personalizzati in grado di soddisfare i particolari requisiti del settore e le applicazioni individuali.

Troppo spesso, i produttori di nastri trasportatori sviluppano prodotti utilizzati dai settori più svariati, obbligando le aziende di trasformazione di prodotti alimentari ad accettare dei piccoli compromessi che potrebbero influenzare le operazioni e la qualità dei prodotti. Considerando queste sfide, Rexnord ha creato il nastro KleanTop™ Serie 590. A differenza dei nastri simili presenti sul mercato, la Serie 590 è stata progettata per l'industria alimentare, offrendo la combinazione ottimale di facilità di pulizia, capacità di trasferimento e resistenza del nastro.

Prestazioni superiori nel settore

Data la combinazione di caratteristiche e vantaggi, la Serie 590 di Rexnord garantisce delle prestazioni superiori per le applicazioni di trasporto di alimenti per le seguenti attività di trasformazione di prodotti alimentari:

- Prodotti da forno
- Snack Food
- Frutta e verdura
- Prodotti ittici
- Pollame



Sistema trasportatore dotato di Catena KleanTop Rexnord Serie 595.

Informazioni sul prodotto

- Nastro modulare in plastica disponibile con una larghezza minima di quattro pollici, con incrementi di mezzo pollice.
- Versione con griglia a filo disponibile con il 25 per cento di area aperta.
- Pignoni lavorati disponibili in versione da 18, 24 e 36 denti, sia nei modelli a pezzo unico (KU) che diviso (KUS).
- Disponibile nei materiali bianco e blu omologati FDA per contrasto visivo e identificazione.



Sistema trasportatore dotato di Catena KleanTop Rexnord Serie 596.

Flat Top

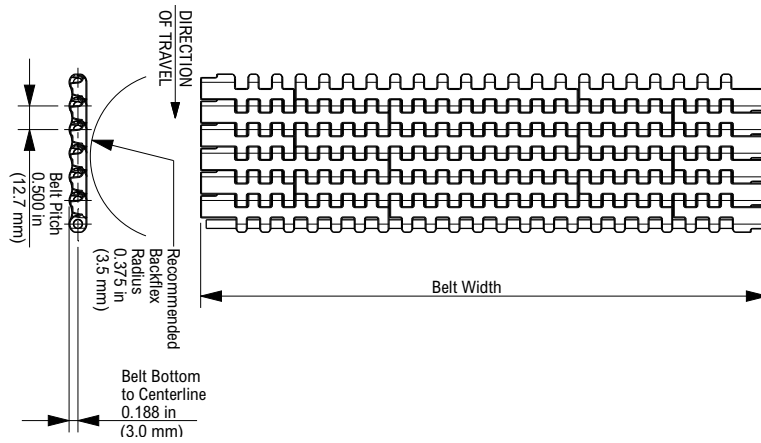
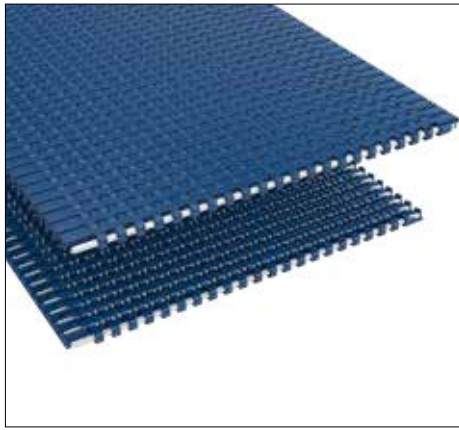

Rexnord 590 Series KleanTop Chain Overview

Chain Type	Material	Standard Pin Material	Working Load (max)		Backflex Radius (min)	Temperature Range °C	
			lbs/ft / N/m	lbs/ft / kg/m		Dry	Wet
SMB595-XXIN	SMB (Blue)	PBT	1.100 / 16.048	1.59 / 7.76	0.375 / 9.5	-40 / 82	-40 / 66
WHT595-XXIN	WHT (White)	PBT	700 / 10.213	1.02 / 4.98		4 / 104	4 / 100
BHT595-XXIN	BHT (Blue)	PBT	700 / 10.213	1.02 / 4.98		4 / 104	4 / 100

General information:

- Plastic modular belt available in minimum width of four inches and increments of a half-inch
- (A) Nominal standard width of the (imperial) Rexnord 590 MatTop Chain is 4 IN and available with increments of 0.5IN

Flush Grid

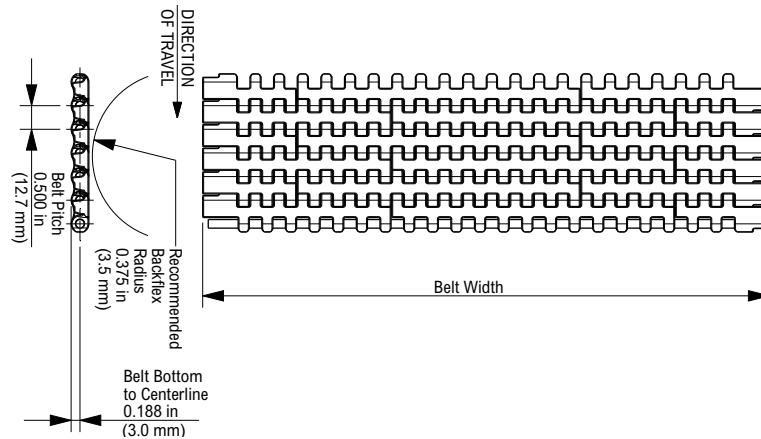
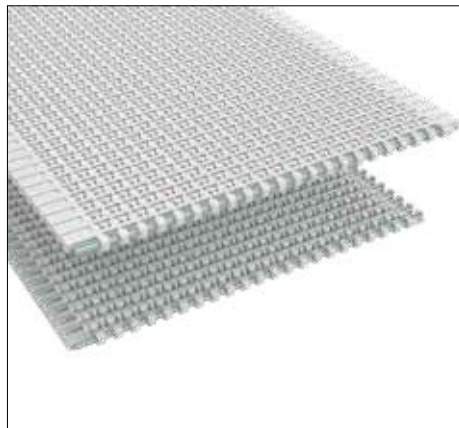

Rexnord 596 Series KleanTop Chain Material Overview

Chain Type	Material	Standard Pin Material	Working Load (max)		Backflex Radius (min)	Temperature Range °C	
			lbs/ft / N/m	lbs/ft / kg/m		Dry	Wet
SMB596-XXIN	SMB (Blue)	PBT	900 / 13.130	1.48 / 7.23	0.375 / 9.5	-40 / 82	-40 / 66
WHT596-XXIN	WHT (White)	PBT	500 / 7295	0.95 / 4.64		4 / 104	4 / 100
BHT596-XXIN	BHT (Blue)	PBT	500 / 7295	0.95 / 4.64		4 / 104	4 / 100

KU590 Thermoplastic Sprocket

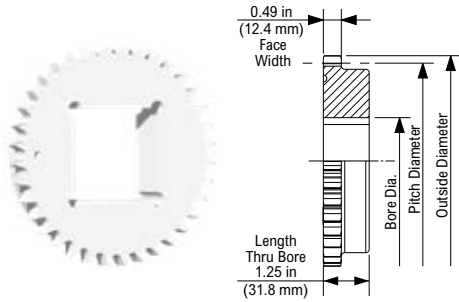

KUS590 Thermoplastic Split Sprocket

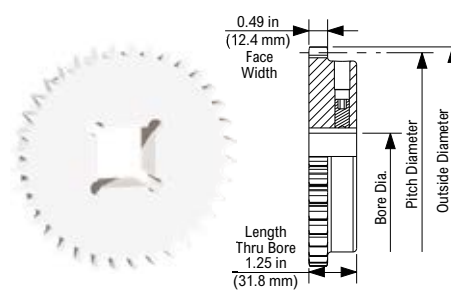

KU590 Thermoplastic Sprocket Information

Number of Teeth		Pitch Diameter		Outside Diameter		Bore Diameter (Shaft-Ready)								Bore Diameter (Idler)				Approximate Weight	
						Round				Square				in		mm			
						in	mm	min	max	in	mm	min	max	min	max	min	max		
actual	effect	in	mm	in	mm	min	max	min	max	min	max	min	max	min	max	min	max	lbs	kg
19T	19T	3.0	77.2	3.0	76.7	1	1-7/16	25	35	1	1-1/2	25	38	1	1-3/4	25	45	0.18	0.08
24T	24T	3.8	97.3	3.8	97.2	1	1-3/4	25	45	1	1-19/32	25	40	1	2	25	50	0.34	0.16
28T	28T	4.5	113.4	4.5	113.9	1	2-1/4	25	55	1	2-1/4	25	55	1	3	25	76	0.54	0.24
36T	36T	5.7	145.7	5.8	146.4	1	3	25	75	1	3	25	75	1	4	25	102	1.00	0.45

KUS590 Thermoplastic Split Sprocket Information

Number of Teeth		Pitch Diameter		Outside Diameter		Bore Diameter (Shaft-Ready)								Bore Diameter (Round)				Approximate Weight	
						Round				Square				in		mm			
						in	mm	min	max	in	mm	min	max	min	max	min	max		
actual	effect	in	mm	in	mm	min	max	min	max	min	max	min	max	min	max	min	max	lbs	kg
36T	36T	5.7	145.7	5.8	146.4	1	2-3/4	25.0	70.0	1	2-1/2	25.0	60.0	1	2-3/4	25.0	70.0	1.05	0.47

Il nastro serie 1500 con passo da 15 mm consente di evitare la caduta dei contenitori e il loro intasamento nei punti di trasferimento del trasportatore. Questi nastri sono studiati per consentire trasferimenti in linea graduale e i trasferimenti a 90°. I nastri della Serie 1500 sono disponibili nelle versioni aperta, chiusa e con superficie gommata; le ultime due versioni sono disponibili con larghezze espresse sia in unità di misura anglosassoni che metriche. Di serie, i nastri vengono forniti in acetilica e polipropilene ad alte prestazioni e resistente alle temperature elevate, per le applicazioni nel settore delle bevande.

Caratteristiche

- Il passo da 15 mm, unitamente al fondo curvo del nastro, riduce l'azione cordale e consente l'utilizzo di piastre di trasferimento molto corte o di fare addirittura a meno del loro utilizzo.
- Il passo ridotto garantisce la perfetta movimentazione dei prodotti, anche per i prodotti più vulnerabili.
- Il pratico sistema di ritenzione dei perni facilita le operazioni di installazione e manutenzione; le versioni con larghezza metrica hanno i tappi arancioni mentre le versioni con larghezza espressa in pollici hanno un sistema di ritenzione dei perni giallo.
- La struttura dei nastri e delle ruote di rinvio garantisce un innesto ottimale e un trasporto bidirezionale affidabile.



Trasportatore di bottiglie di vino con nastro 1505



Trasportatore con nastro SGDP1505 XP

Programma	
1505 Superficie Chiusa	Superficie chiusa; idonea per contenitori in vetro (instabili) e in PET e altri prodotti delicati
1506 Superficie Aperta	26% di area aperta per un flusso d'acqua ed aria ottimali; ideale per la movimentazione di lattine per bibite
1505 SuperGrip	Superficie gommata per nastri inclinati e in discesa, con pacchi e per applicazioni di misurazione; è possibile l'inserimento del sistema Positrack e un rientro di 44 mm. Angoli standard fino a 20°
DTS®	Sistema di trasferimento dinamico a modulo singolo per i trasferimenti a spostamento automatico verso sinistra o verso destra per evitare piastre abbandonate con trasferimenti a 90°; di serie, viene fornito il sistema di guida Positrack
Positrack	Positrack Guide per l'inserimento preciso del nastro nel trasportatore (solo versione metrica e DTS)
Accessori per i nastri	Facchini e sponde laterali per applicazioni speciali nell'industria alimentare (solo versioni in pollici)
1553 Accessori	La maggior densità dei rullini protegge e supporta meglio il prodotto La catena Rexnord 1553 LBP MatTop funziona con i pignoni standard serie 1500, semplificando il design del trasportatore

Flat Top 1505 Imperial Sizes

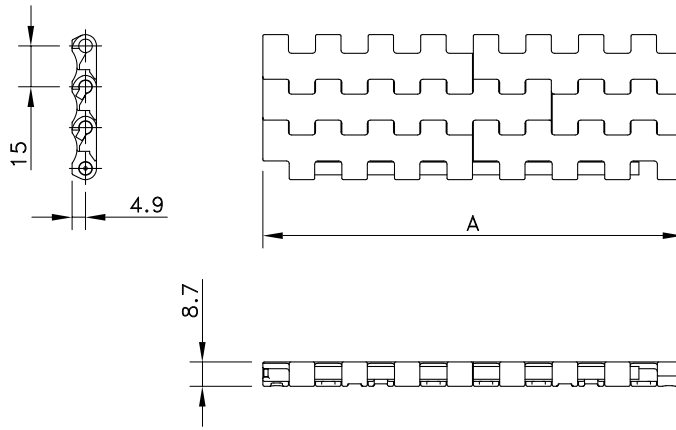
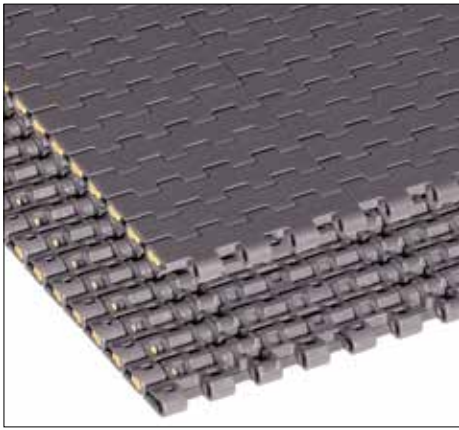

Assembly	Belt Type	Code Number*	Temperature range °C		Working Load (max.) N/m (21°C)	Weight kg/m ²	Backflex Radius (min.) mm
			Dry	Wet			
HP-Acetal with PBT pins							
Standard	HP 1505	I1505HPKxx	-40 to +80	-40 to +65	13200	6.24	25
DTS Left	HP 1505 DTS SX	81413971					
DTS Right	HP 1505 DTS DX	81414111					
HT-Polypropylene with Polypropylene Pins							
Standard	HT 1505	I1505HTKxx	4 to 104	4 to 104	7300	4.52	25
WHT-Polypropylene with PP Pins							
Standard	WHT 1505	I1505WHTKxx	4 to 104	4 to 104	7300	4.50	25
WSM-Acetal with PBT Pins							
Standard	WSM 1505	I1505WSMKxx	-40 to +80	-40 to +65	13200	6.20	25
SMB-Acetal with PBT Pins							
Standard	SMB 1505	I1505SMBKxx	-40 to +80	-40 to +65	13200	6.20	25
FRPLUS - High performance flame retardant polymer - Acetal Pins							
Standard	FRPLUS 1505	I1505FRPLUSKxx	-18 to +82	-40 to +65	7300	6.99	25

* In code numbers xx corresponds with the belt width (A). Standard nominal widths of these belts begin at 3" with 3" increments, or optionally 3/4" up to 96". NOTE: 3 3/4" is impossible. Example: I1505HPK06.75 is a 6.75" wide belt. See also page 223.

If you need flights or sideguards, describe the belt by choosing from the required options listed in the 2nd column of the table:

Material	WHT or WSM or SMB	
Belt type	1505	
Width (A)	K - xx IN	
Flights	F1 or F2	Standard height of 1" (25.4 mm), 2" (50.8 mm) or special height in mm
Pitch between flights	T..P	Flights on every .. th row
Flight side-indent	N.. (in inches)	Minimal 1 7/8" (48 mm) with 3/4" (19 mm) increments
Sideguards	S2IN	Standard height of 2"

Example: BLT 1505 -12IN_F50mm_T4P_N1.88IN_S2IN is a 1505 Flat Top belt, made of blue polyethylene, width 12", special 50 mm high flights on every 4th row at 1 7/8" from the sides and 2" high sideguards.

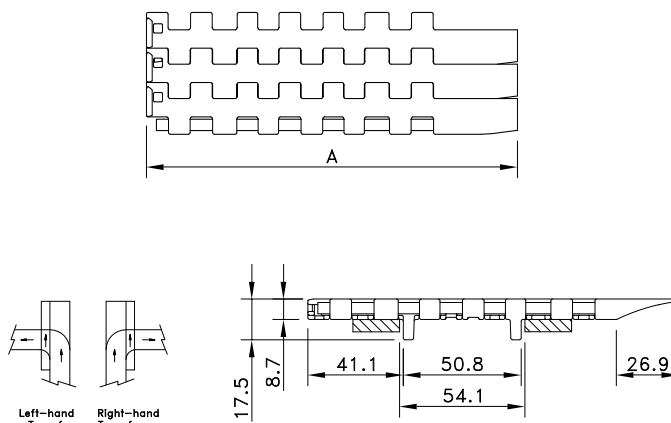

Flush Grid 1506 Imperial Sizes

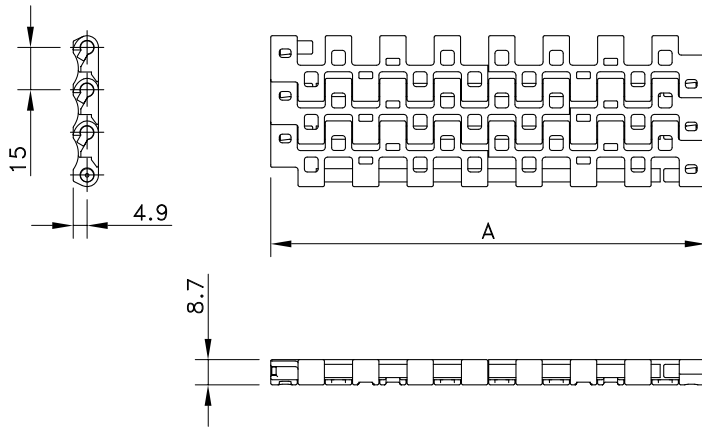
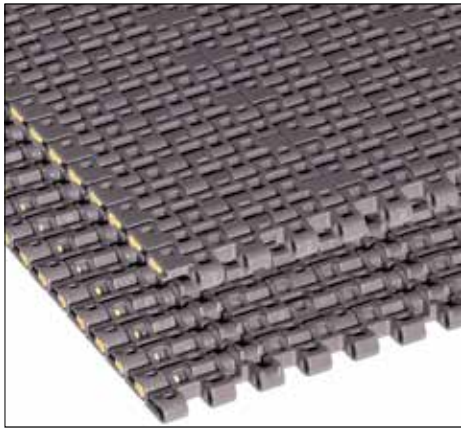

Assembly	Belt Type	Code Number*	Temperature range °C		Working Load (max.) N/m (21°C)	Weight kg/m ²	Backflex Radius (min.) mm
			Dry	Wet			
HP-Acetal with PBT Pins							
Standard	HP 1506	I1506HPKxx	-40 to +80	-40 to +65	13200	6.24	25
DTS Left	HP 1505 DTS SX	81413971					
DTS Right	HP 1505 DTS DX	81414111					
HT-Polypropylene with PBT Pins							
Standard	HT 1506	I1506HTKxx	4 to 104	4 to 104	7300	4.52	25
BLT-Polyethylene with Polyethylene Pins							
Standard	BLT 1506	I1506BLTKxx	-70 to +35	-70 to +35	2800	4.80	25
WHT-Polypropylene with PBT Pins							
Standard	WHT 1506	I1506WHTKxx	4 to 80	4 to 65	7300	4.50	25
BHT-Polypropylene with PBT Pins							
Standard	BHT 1506	I1506BHTKxx	4 to 80	4 to 65	7300	4.50	25
SMB-Acetal with PBT Pins							
Standard	SMB 1506	I1506SMBKxx	-40 to +80	-40 to +65	13200	6.20	25
FRPLUS-High performance flame retardant polymer - Acetal Pins							
Standard	FRPLUS 1506	I1506FRPLUSKxx	-18 to +82	-18 to +60	7300	6.93	25

* In code numbers xx corresponds with the belt width (A). Standard nominal widths of these belts begin at 3" (76.2 mm), with 3" increments, or optionally ¼" up to 120". NOTE: 3¾" is impossible. Example: I1506HPK06.75 is a 6.75" wide belt. See also page 208.

If you need flights or sideguards, describe the belt by choosing from the required options listed in the 2nd column of the table:

Material	BLT or WHT or BHT or SMB	
Belt type	1506	
Width (A)	K- xx IN	
Flights	F1 or F2	Standard height of 1" (25.4 mm), 2" (50.8 mm) or special height in mm
Pitch between flights	T..P	Flights on every .. th row
Flight side-indent	N.. (in inches)	Minimal 1 7/8" (48 mm) with ¼" (19 mm) increments
Sideguards	S2IN	Standard height of 2"

Example: WSM1506-6IN_F2IN_T05P_N0IN is a 1506 Flush Grid belt, made of white acetal, width 15¾", 1" high flights on every 8th row at 1/8" from the sides and 2" high sideguards.



Flight for 1500-series imperial

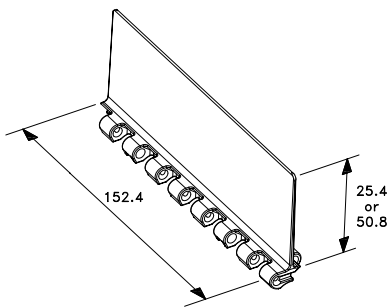

Sideguards for 1500-series imperial

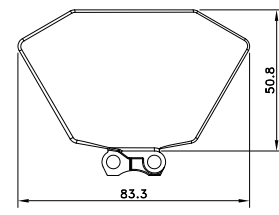

FlatTop 1505 Metric Sizes

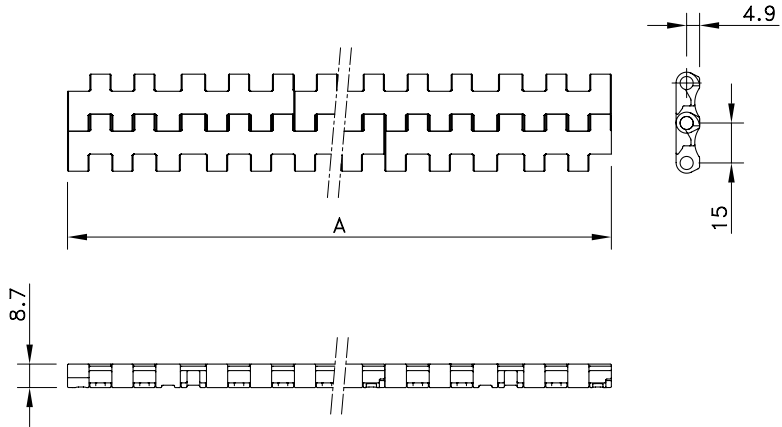
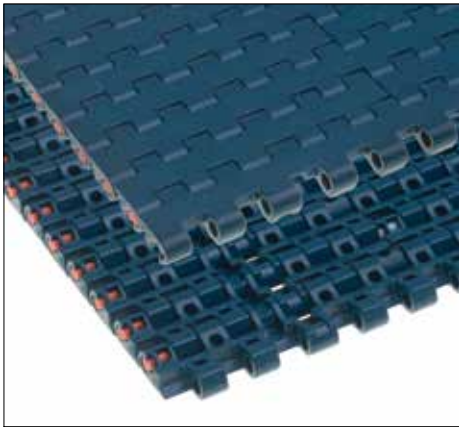

Assembly	Belt Type	Code Number*	Temperature range °C		Working Load (max.) N/m (21°C)	Weight kg/m ²	Backflex Radius (min.) mm
			Dry	Wet			
XLG-Acetal with PBT Pins							
Standard	FT 1505 XLG	873.44.xx	-40 to +80	-40 to +65	13200	6.35	25
Double Positrack	FTDP 1505 XLG	873.54.xx					
PSX Advanced Performance Polymer Alloy with PBT pins							
Standard	FT 1505 PSX	873.77.xx	4 to 104	4 to 104	13200	4.49	25
Double Positrack	FTDP 1505 PSX	873.76.xx					
XP-Polypropylene with Polypropylene Pins							
Standard	FT 1505 XP	873.46.xx	4 to 104	4 to 104	7300	4.49	25
Double Positrack	FTDP 1505 XP	873.56.xx					
WSM-Acetal with PBT Pins							
Standard	WSM 1505 FT	873.48.xx	-40 to +80	-40 to +65	13200	6.35	25
Double Positrack	WSM 1505 FTDP	873.57.xx					
WHT-Polypropylene with PP Pins							
Standard	WHT 1505 FT	873.49.xx	4 to 104	4 to 104	7300	4.49	25
Double Positrack	WHT 1505 FTDP	873.58.xx					
Dry-PT - PBT Pins							
Standard	Dry-PT 1505 FT	I1505DRYPTFTxx	4 to 104	4 to 104	13200	4.49	25
Double Positrack	Dry-PT 1505 FTDP	I1505DRYPTFTDPKxx					
FRPLUS-High performance flame retardant polymer - Acetal Pins							
Standard	FRPLUS 1505 FT	I1506FRPLUSKxx	-18 to +82	-18 to +60	7300	6.99	25
Double Positrack	FRPLUS 1505 FTDP	I1506FRPLUSFTDPKxx					

* In code numbers xx corresponds with the belt width (A), starting with 11 for 170 mm, 12 for 255 mm and so on in steps of 85 mm, up to 6120 mm; wider belts upon request. See page 208 for all code numbers. Cut to width options are possible.

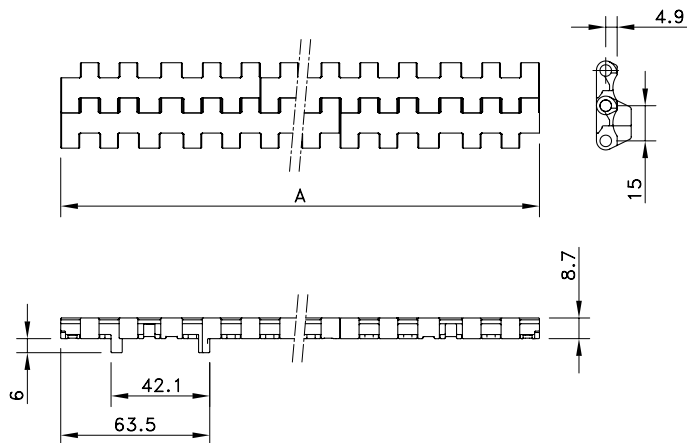
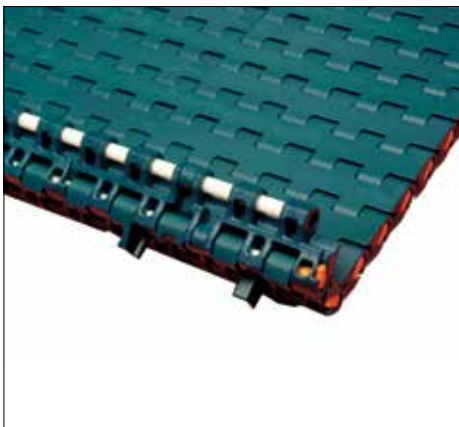

Positrack 1505 Metric

Flat Top 1505 Supergrip

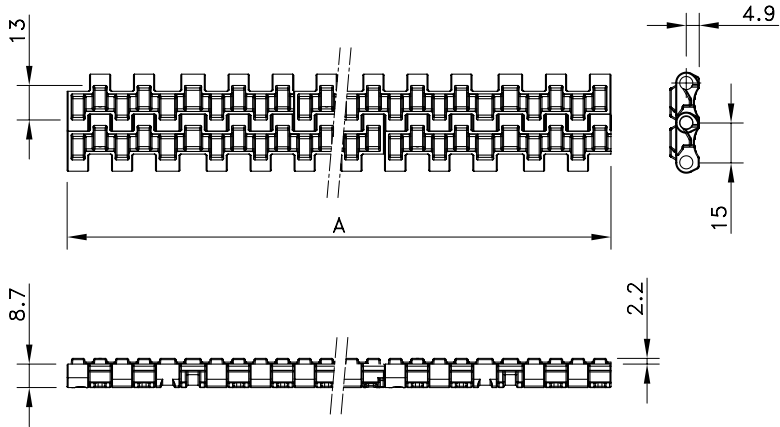
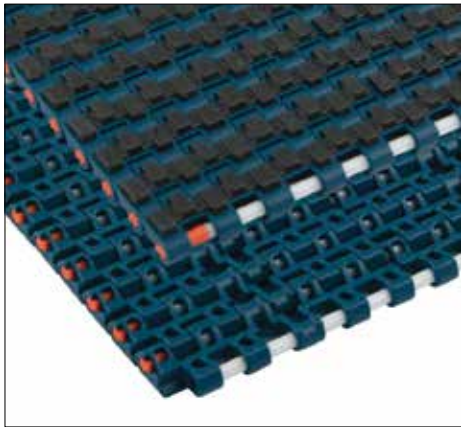

Assembly	Belt Type	Code Number*	Temperature range °C		Working Load (max.) N/m (21°C)	Weight kg/m ²	Backflex Radius (min.) mm
			Dry	Wet			
XLG-Acetal with PBT Pins							
Standard	SG 1505 XLG	878.00.xx	-40 to +80	-40 to +65	13200	6.35	25
Double Positrack	SGDP 1505 XLG	878.12.xx					
Side-Indent	SGS 1505 XLG	878.01.xx					
Side-Indent Double Positrack	SGSDP 1505 XLG	878.13.xx					
XP-Polypropylene with PBT Pins							
Standard	SG 1505 XP	878.02.xx	4 to 80	4 to 65	7300	4.49	25
Double Positrack	SGDP 1505 XP	878.14.xx					
Side-Indent	SGS 1505 XP	878.03.xx					
Side-Indent Double Positrack	SGSDP 1505 XP	878.15.xx					
WSM-Acetal with PBT Pins							
Standard	SG 1505 WSM	878.06.xx	-40 to +80	-40 to +65	13200	6.35	25
Double Positrack	SGDP 1505 WSM	878.16.xx					
Side-Indent	SGS 1505 WSM	878.07.xx					
Side-Indent Double Positrack	SGSDP 1505 WSM	878.17.xx					
WHT-Polypropylene with PBT Pins							
Standard	SG 1505 WHT	878.04.xx	4 to 80	4 to 65	7300	4.49	25
Side-Indent	SGS 1505 WHT	878.05.xx					

* In code numbers xx corresponds with the belt width (A), starting with 11 for 170 mm, 12 for 255 mm and so on in steps of 85 mm, up to 6120 mm. SuperGrip Side-indent versions start with 255 mm width. See page 208 for all code numbers. Cut to width options are possible. Side-indent in SuperGrip versions is 44 mm.

Rubber top is a black elastomere, with a hardness of 40 (XP) or 50 (XLG, WSM) or 60 (WHT) shore A.

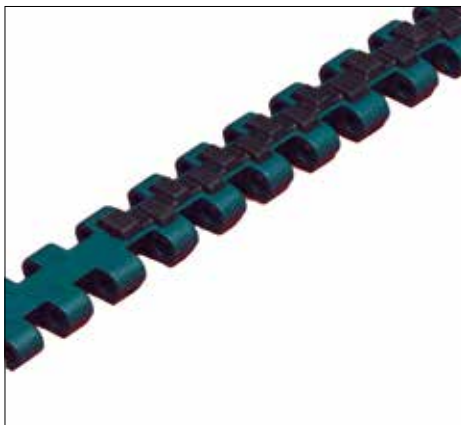

1505 Supergrip Side-Indent

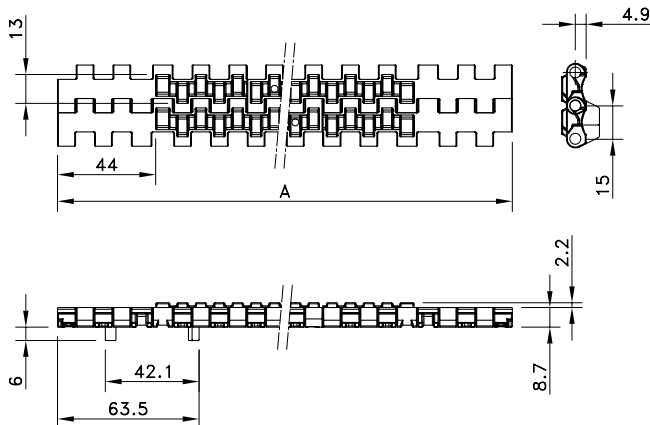

1505 Supergrip Side-Indent with Positrack

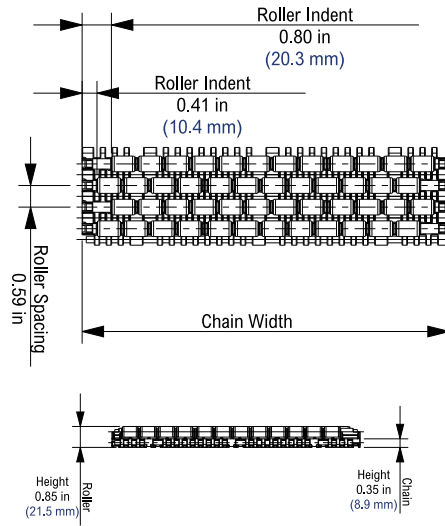

Assembly	Belt Type	Code Number*	Temperature range °C		Working Load (max.) N/m (21°C)	Weight kg/m ²	Backflex Radius (min.) mm
			Dry	Wet			
HP-Acetal with PBT pins							
Standard	HP 1553	HP1553-xx	-40 to +82	-40 to +66	13131	14.84	25.4



Tab guide 8500-series

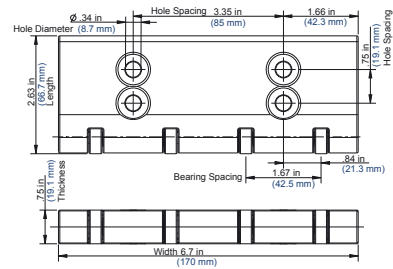
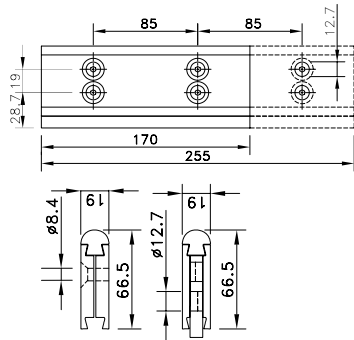

Specification drawing for the 170-millimeter width size (part number 10478853) of the 1500 Series MatTop Molded Dynamic Nose-over Bar.

Description	Part Number	Overall Length
Static Nose-over Bar ULF		
NOSE OVER 905 L6IN STANDARD ULF	10483148	6.0 in
NOSE OVER 905 L6IN LOW-PROF M6 ULF	10483150	6.0 in
NOSE OVER 905 L6IN L170MM M6 ULF	10476256	170 mm (M6)
NOSE OVER 905 L255MM M6 ULF	10476257	255 mm (M6)
Dynamic Nose-over Bar		
NOSEOVER ASSY 1500 DYN 6IN BWR	10478852	6.0 in
NOSEOVER ASSY 1500 DYN 3IN BWR	10478945	3.0 in
NOSEOVER ASSY 1500 DYN 170MM BWR	10478853	170 mm
NOSEOVER ASSY 1500 DYN 85MM BWR	10478976	85 mm

Split Sprockets NS1500

NSH - Hygienic Split Sprockets

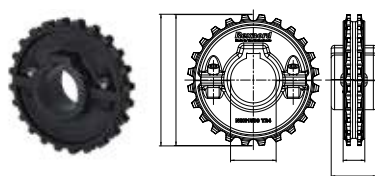
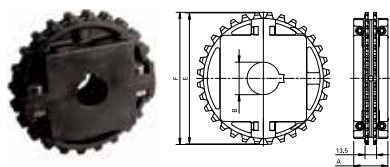

Sprocket Type	Code Number	Number of Teeth	Bore	Pitch Diameter	Outside Diameter	Hub Diameter
			B	E	F	A
			mm	mm	mm	mm

Split molded sprocket NSH1500

NSH1500-24T_30MM_1KW	10378150	24	30	114.9	115.5	40.0
NSH1500-24T_40MM_1KW	10378415	24	40			
NSH1500-32T_30MM_1KW	10378419	32	30	153.4	154.8	
NSH1500-32T_40MM_1KW	10378423	32	40			

NS1500 Not suitable in combination with FTDP, SGDP and SGSDP due to the Positrack lugs.

Round Bores

NS1500-24T_25MM_1KW_PA	10028510	24	25	114.9	115.5	40.0
NS1500-24T_30MM_1KW_PA	10028512	24	30			
NS1500-24T_35MM_1KW_PA	10331965	24	35			
NS1500-24T_40MM_1KW_PA	10028514	24	40			
NS1500-32T_25MM_1KW_PA	10331228	32	25	153.4	154.8	
NS1500-32T_30MM_1KW_PA	10028526	32	30			
NS1500-32T_35MM_1KW_PA	10331964	32	35			
NS1500-32T_40MM_1KW_PA	10028528	32	40			

Square Bores

NS1500-24T_40MM_S_PA	10028516	24	40	114.9	115.5	40.0
NS1500-24T_60MM_S_PA	10333775	24	60			
NS1500-32T_40MM_S_PA	10028530	32	40	153.4	154.8	
NS1500-32T_60MM_S_PA	10028531	32	60			

Split Sprockets KU1500

Classic Sprockets KU1500

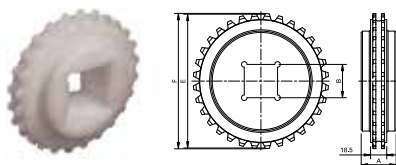
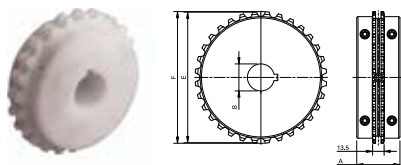

Split Sprockets 1505 Machined

Round Bores

KUS1500-24T_25MM_1KW_PA	10331141	24	25	114.9	115.5	50.8
KUS1500-24T_30MM_1KW_PA	10131508	24	30			
KUS1500-24T_35MM_1KW_PA	10331889	24	35			
KUS1500-24T_40MM_1KW_PA	10131510	24	40			

Classic Sprockets 1505 Machined

Round Bores

KU1500-12T_30MM_1KW_PA	10331359	12	30	58.1	58.2	24.1
KU1500-16T_30MM_1KW_PA	10331361	16	30	77.1	77.7	31.8
KU1500-24T_30MM_1KW_PA	10331371	24	30	114.9	115.5	40.0
KU1500-24T_40MM_1KW_PA	10332089	24	40			
KU1500-32T_30MM_1KW2SS_PA	10071092	32	30	153.4	154.8	40.0
KU1500-32T_40MM_1KW_PA	10332094	32	40			

Square Bores

KU1500-24T_25MM_S_PA	10330971	24	25	114.9	115.5	40.0
KU1500-32T_40MM_S_PA	10332096	32	40	153.4	154.8	40.0

Il nastro serie 8500 da ¾ di pollice dispone di numerose caratteristiche strutturali che lo rendono idoneo per l'industria delle bevande, degli imballaggi e alimentare. Il passo ridotto del nastro garantisce un funzionamento senza problemi. La serie 8500 è disponibile in una versione chiusa e in una aperta. Le versioni stampate in base alla larghezza sono disponibili con le guide Tab per le applicazioni a singola linea. I nastri vengono forniti di serie in acetalica ad elevate prestazioni e in propilene.

Caratteristiche

- Movimentazione perfetta dei prodotti grazie al passo ridotto e al materiale HP a basso attrito. La rigidità dei moduli garantisce una planarità ottimale del nastro.
- Il passo ridotto da 19,05 mm riduce l'azione cordale e consente l'utilizzo di piastre di trasferimento ridotte.
- Bordi esterni arrotondati per un miglioramento dei trasferimenti laterali e migliore movimentazione dei prodotti.
- La ritenzione dei perni Twist-lock™ mediante un tappo incernierato evita la perdita del tappo e consente un agevole accesso ai perni per le operazioni di installazione e manutenzione.
- Il nastro serie 8500 è abbinato ai nastri a catena FTM 1060, FGM 1050 o FT 1050, in modo da creare un abbinamento perfetto tra corsa rettilinea e trasportatori curvilinei.



Elevazione di bulloni su nastro 8505



Vuoti lattine 3-Piece su HP8506 K450 MTW

Programma

8505 Solid Top 8506	La superficie chiusa e l'elevata resistenza ne garantiscono l'idoneità sia per i contenitori di vetro che in PET
Perforated Top	22% di area aperta per un flusso d'acqua ed aria ottimali; ideale per la produzione e il trattamento di lattine per bibite
DTS®	Sistema di trasferimento dinamico a modulo singolo per i trasferimenti a spostamento automatico verso sinistra o verso destra per evitare piastre morte con trasferimenti a 90°; di serie, viene fornito il sistema di guida Positrack
Accessori per i nastri	Facchini, sponde laterali e tapparelle per applicazioni speciali nell'industria alimentare

Solid Top 8505

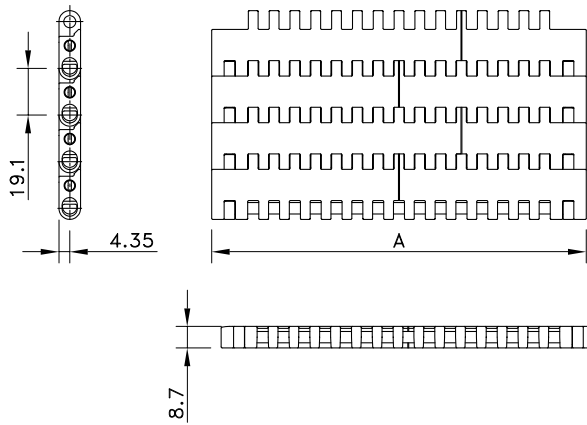
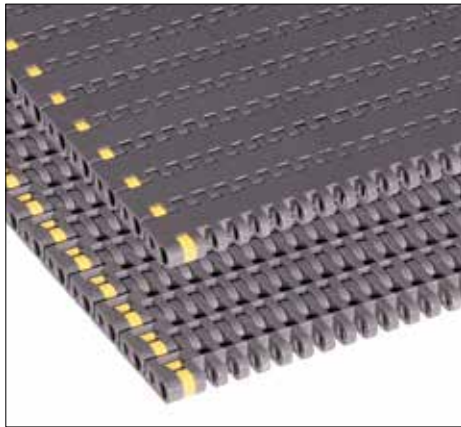

Assembly	Belt Type	Code Number*	Temperature range °C		Working Load (max.) N/m (21°C)	Weight kg/m ²	Backflex Radius (min.) mm
			Dry	Wet			
HP-Acetal with Polypropylene Pins							
Standard	HP 8505	I8505HPKxx	-40 to +80	-40 to +65	29000	8.89	25
DTS Left/Positrack	HP8505DTS-4.5IN_MTW_PT_LH	10028436					
DTS Right/Positrack	HP8505DTS-4.5IN_MTW_PT_RH	10028437					
WHT-Polypropylene with Polypropylene Pins							
Standard	WHT 8505	I8505HTKxx	5 to 105	5 to 105	16000	5.96	25
FRPLUS - High performance flame retardant polymer - Acetal Pins							
Standard	FRPLUS 8505	I8505FRPLUSKxx	-18 to +82	-18 to +60	16000	9.77	25

* In code numbers xx corresponds with the belt width (A). Standard widths of these belts begin at 6", with 6" increments up to 120"; special widths begin at 2 1/3" with 1/8" increments. See also page 208.

If you require flights, sideguards or tab guides, please describe the belt by choosing from the options listed in the 2nd column of the table:

Material	HP or WHT	
Belt type	8505	
Width (A)	K - xx IN	Belts with flights have a minimal width of 6"
Flights	F3 or F2 or F1	Standard height of 3", 2", 1" or special height in mm
Pitch between flights	T..P	Flights on every .. th row; with sideguards it must correspond to an even number of rows
Flight side-indent	N.. (in inches)	Any indent with increments of 0.25IN is possible
Sideguards	SG2 or SG1	Standard height of 2" or 1"
Tab guides	D..	TAB1 is only one row; TAB2 is two rows
Distance between Tabs		Minimal 3" with increments of 1/3"
Pitch between Tabs	D..P	Must correspond to an even number of rows

Example: HP 8505 K16 1/3 F3 T4P N2 1/3 TAB2 D3 D4P is a 8505 Solid Top belt, made of dark grey acetal, width 16 1/3", 3" high flights on every 4th row at 2 1/3" from the sides, no sideguards and 2 rows of tabs with a distance in-between of 3" on every 4th row.

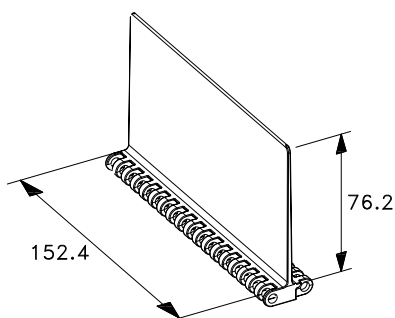

Sideguards 8500-series

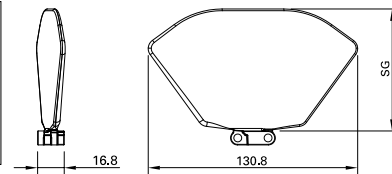

Flight 8500-series for inclined applications

Perforated Top 8506

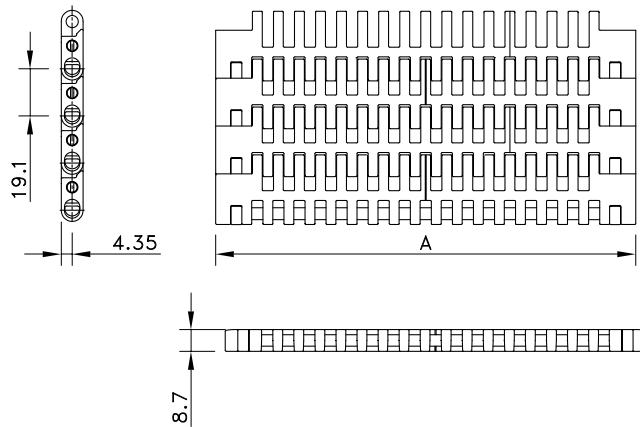
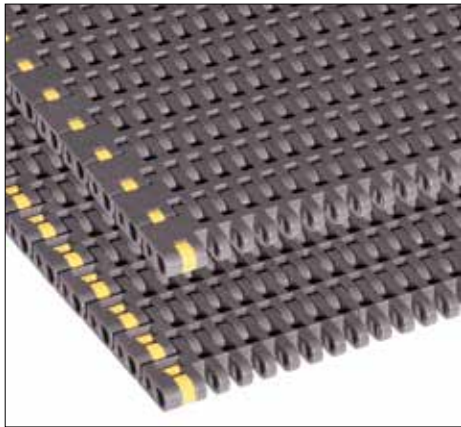

Assembly	Belt Type	Code Number*	Temperature range °C		Working Load (max.) N/m (21°C)	Weight kg/m ²	Backflex Radius (min.) mm
			Dry	Wet			
HP-Acetal with Polypropylene Pins							
Standard	HP 8505	I8506HPKxx	-40 to +80	-40 to +65	29000	8.89	25
DTS Left/Positrack	HP8505DTS-4.5IN_MTW_PT_LH	10028436					
DTS Right/Positrack	HP8505DTS-4.5IN_MTW_PT_RH	10028437					
WHT-Polypropylene with Polypropylene Pins							
Standard	WHT 8506	I8506WHTKxx	5 to 105	5 to 105	16000	5.96	25
FRPLUS - High performance flame retardant polymer - Acetal Pins							
Standard	FRPLUS	I8505FRPLUSKxx	-18 to +82	-18 to +60	16000	9.67	25

* In code numbers xx corresponds with the belt width (A). Standard widths of these belts begin at 6", with 6" increments up to 120"; special widths begin at 2 1/3" with 1/8" increments. See also page 208.

If you require flights, sideguards or tab guides, please describe the belt by choosing from the options listed in the 2nd column of the table:

Material	HP or WHT	
Belt type	8506	
Width (A)	K - xx IN	Belts with flights have a minimal width of 6"
Flights	F3 or F2 or F1	Standard height of 3", 2", 1" or special height in mm
Pitch between flights	T..P	Flights on every .. th row; with sideguards it must correspond to an even number of rows
Flight side-indent	N.. (in inches)	Minimal 1 1/3" with 1/3" increments; in case of sideguards indents 1 1/2" or 2 1/4" only
Sideguards	S2IN / S3IN	Standard height of 3", 2" or 1"
Tab guides	TAB1 or TAB2	TAB1 is only one row; TAB2 is two rows
Distance between Tabs	D..	Minimal 3" with increments of 3/8"
Pitch between Tabs	D..P	Must correspond to an even number of rows

Example: WHT 8506 K7.50 SG2 N1 1/2 is a 8506 Perforated Top belt, made of white Polypropylene, width 7.5", 2" high sideguards at 1 1/2" from the sides. No flights, tab guides and DTS.

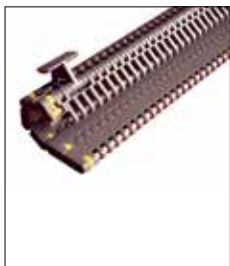

Tab guide 8500-series

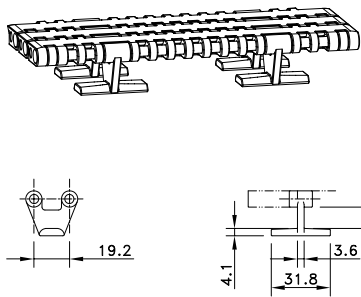

Dynamic transfer system 8500-series

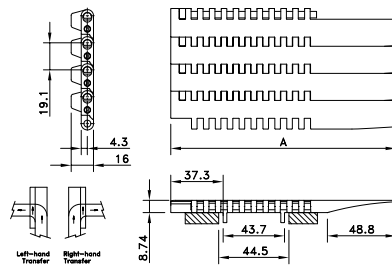

Split Sprockets

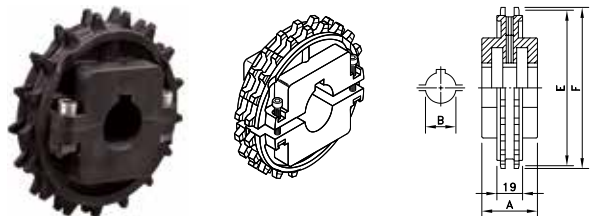

Classic Sprockets

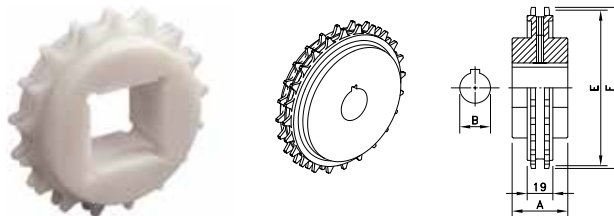

Sprocket Type	Code Number	Number of Teeth	Bore	Pitch Diameter	Outside Diameter	Hub Width
			B	E	F	A
			mm	mm	mm	mm

Split Sprockets

Round Bores

NS8500-17T_25MM_1KW_PA	10028670	17	25	104.7	105.4	39
NS8500-17T_30MM_1KW_PA	10028671	17	30			
NS8500-17T_35MM_1KW_PA	10331962	17	35			
NS8500-21T_25MM_1KW_PA	10028678	21	25	129.0	130.0	
NS8500-21T_30MM_1KW_PA	10028679	21	30			
NS8500-21T_35MM_1KW_PA	10331963	21	35			
NS8500-21T_40MM_1KW_PA	10028680	21	40	147.3	148.3	
NS8500-24T_25MM_1KW_PA	10028695	24	25			
NS8500-24T_30MM_1KW_PA	10028696	24	30			
NS8500-24T_35MM_1KW_PA	10331959	24	35	153.4	154.7	
NS8500-25T_25MM_1KW_PA	10028707	25	25			
NS8500-25T_30MM_1KW_PA	10019777	25	30			
NS8500-25T_35MM_1KW_PA	10331960	25	35			

Square Bores

NS8500-17T_25MM_S_PA	10331199	17	25	104.7	105.4	39
NS8500-17T_30MM_S_PA	10331599	17	30			
NS8500-17T_35MM_S_PA	10370600	17	35			
NS8500-21T_25MM_S_PA	10331200	21	25	129.0	130.0	
NS8500-21T_40MM_S_PA	10028681	21	40			
NS8500-21T_60MM_S_PA	10187289	21	60			
NS8500-24T_25MM_S_PA	10331201	24	25	147.3	148.3	
NS8500-24T_35MM_S_PA	10376561	24	35			
NS8500-25T_25MM_S_PA	10331202	25	25			
NS8500-25T_30MM_S_PA	10331602	25	30	153.4	154.7	
NS8500-25T_35MM_S_PA	10370601	25	35			

Classic Sprockets

Round Bores

KU8500-24T_30MM_1KW_PA	10071597	24	30	147.3	148.3	35
KU8500-25T_50MM_1KW_PA	10332943	25	50	153.4	154.7	

Square Bores

KU8500-17T_40MM_1KW_PA	10332361	17	40	104.7	105.4	35
KU8500-25T_40MM_1KW_PA	10332363	25	40	153.4	154.7	

Il nastro Serie 5930 con passo da $\frac{3}{4}$ è destinato ai carichi leggeri-medi nella produzione e movimentazione di lattine per bevande e nell'industria alimentare. I nastri garantiscono un funzionamento scorrevole. La serie 5930 è disponibile in una versione chiusa e in una aperta. Di serie, i nastri vengono forniti in polipropilene e acetilica.

Caratteristiche

- Il passo da 19,05 mm riduce l'azione cordale.
- Il passo ridotto consente l'utilizzo di piastre di trasferimento ridotte.
- I bordi smussati e le cerniere chiuse garantiscono la perfetta movimentazione del prodotto.
- Ritenzione dei perni mediante un modulo a estremità chiusa e un modulo a estremità cieca.
- I nastri della serie 5930 con facchini, sponde laterali e tapparelle sono stati sostituiti dalla serie 8500; questa serie è identica relativamente al passo, allo spessore e alle larghezze standard.

Programma	
5935 Solid Top	Superficie chiusa; idonea per contenitori in PET e altri prodotti leggeri
5936 Perforated Top	22% di area aperta per un flusso d'acqua ed aria ottimali; ideale per la produzione e il trattamento di lattine per bibite
5935 Vacuum Top	Versione Solid Top con piccoli fori anche per i trasportatori vacuum nelle linee di produzione di lattine per bibite



Scarico lavatrice di lattine per bibite con nastro 5936



Trattamento Di Lattine Per Bibite Su Nastro 5935 Vacuum

Solid Top 5935

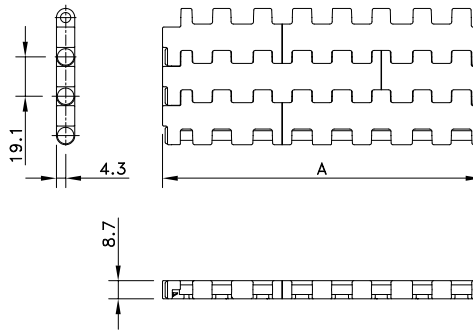
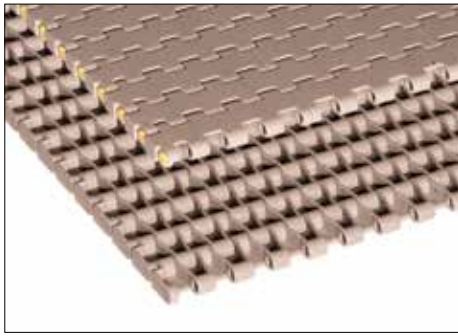

Assembly	Belt Type	Code Number*	Temperature range °C		Working Load (max.) N/m (21°C)	Weight kg/m ²	Backflex Radius (min.) mm
			Dry	Wet			
HP-Acetal With Polyester Pins							
Standard	HP 5935	I5935HPKxx	-40 to +80	-40 to +65	13000	6.35	25
Standard	HP 5935 K24		-40 to +80	-40 to +65	13000	6.35	25
Standard	HP 5935 K48		-40 to +80	-40 to +65	13000	6.35	25
Standard	HP 5935 K96		-40 to +80	-40 to +65	13000	6.35	25
LF-Acetal with Polypropylene Pins							
Standard	LF 5935	I5935LFKxx	+4 to +80	-40 to +65	13000	6.35	25
HT-POLYPROPYLENE WITH POLYPROPYLENE PINS							
Standard	HT 5935	I5935HTKxx	+4 to +104	+4 to +104	7000	4.92	25
FRPLUS - HIGH PERFORMANCE FLAME RETARDANT POLYMER WITH ACETAL PINS							
Standard	FRPLUS 5935	I5935FRPLUS	-18 to +82	-18 to +60	7000	6.99	25

* In code numbers xx corresponds with the belt width (A). Standard widths of these belts begin at 9" with 3" increments up to 120"; special widths begin at 3" with ¼" increments. See also page 208.

Perforated Top 5936

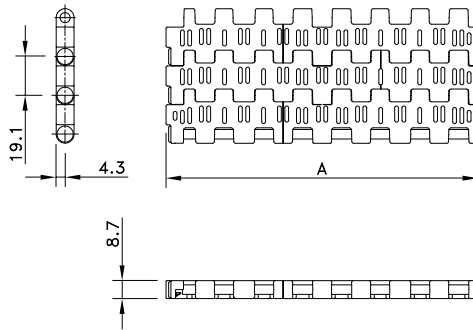
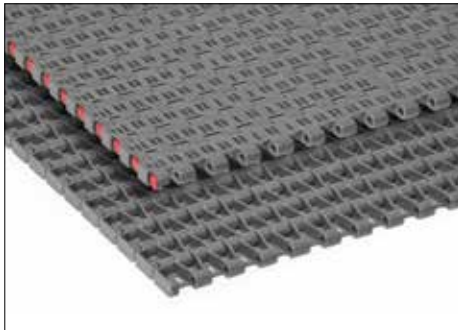

Assembly	Belt Type	Code Number*	Temperature range °C		Working Load (max.) N/m (21°C)	Weight kg/m ²	Backflex Radius (min.) mm
			Dry	Wet			
HP-Acetal With Polyester Pins							
Standard	HP 5936	I5936HPKxx	-40 to +80	-40 to +65	13000	5.90	25
Standard	HP 5936 K24	I5936HP653743	-40 to +80	-40 to +65	13000	5.90	25
Standard	HP 5936 K48	I5936HP653753	-40 to +80	-40 to +65	13000	5.90	25
Standard	HP 5936 K96	I5936HP653763	-40 to +80	-40 to +65	13000	5.90	25
LF-Acetal with Polypropylene Pins							
Standard	LF 5936	I5936LFKxx	+4 to +80	+4 to +65	13000	5.90	25
HT-Polypropylene With Polypropylene Pins							
Standard	HT 5936	I5936HTKxx	+4 to +104	+4 to +104	7000	4.49	25

* In code numbers xx corresponds with the belt width (A). Standard widths of these belts begin at 9" with 3" increments up to 120"; special widths begin at 3" with ¼" increments. See also page 211.

Vacuum Top 5935

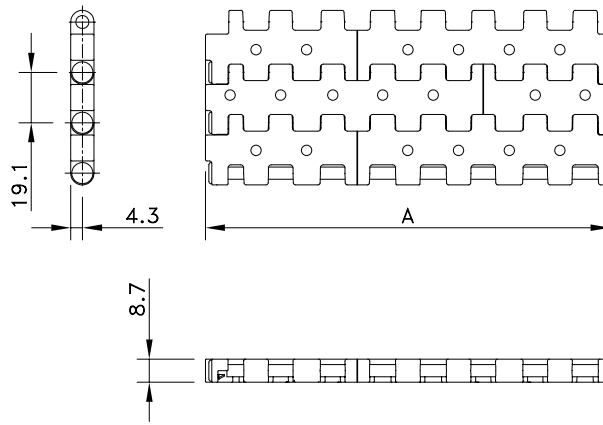
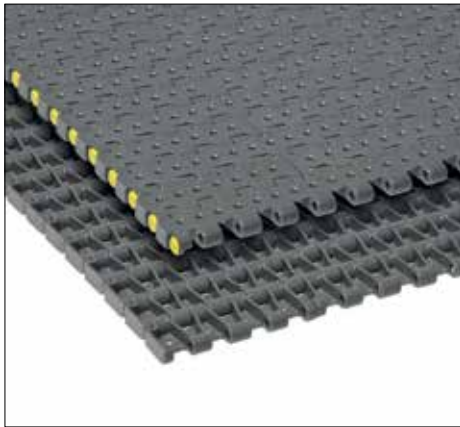

Assembly	Belt Type	Temperature range °C		Working Load (max.) N/m (21°C)	Weight kg/m ²	Backflex Radius (min.) mm
		Dry	Wet			
HP-Acetal with Polypropylene Pins						
Standard	HP 5935 V	-40 to +80	-40 to +65	13000	6.35	25
LF-Acetal with Polypropylene Pins						
Standard	LF 5935 V	-40 to +80	-40 to +65	13000	6.35	25
HT-Polypropylene with Polypropylene Pins						
Standard	HT 5935 V	5 to 105	5 to 105	7000	4.92	25
FRPLUS - High performance flame retardant polymer - Acetal Pins						
Standard	FRPLUS 5935 V	-18 to +82	-18 to +60	7000	6.93	25

As the patterns of the holes will be made to order, these belts will be supplied upon request.

Version E7 (holes in line) Holes diameter: 3,2 - 4 - 5,1 mm.

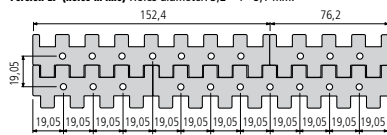

Version E78 (holes in "diamond" pattern) Holes diameter: 3,2 - 4 - 5,1 mm.

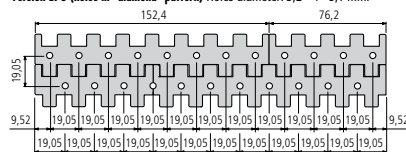

Version E8 (holes in line) Holes diameter: 3,2 - 4 - 5,1 mm.

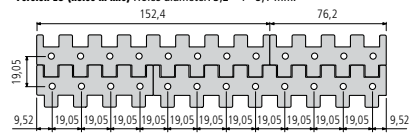

Hole Diameter		Hole Spacing		Holes per Module	Open Area
in	mm	in	mm		
1/8	3.18	3/8	9.53	15	6.2%
1/8	3.18	3/4	19.05	8	4.3%
9/64	3.57	3/4	19.05	8	4.9%
9/64	3.57	3/8	9.53	15	7.3%
5/32	3.97	3/4	19.05	8	5.5%
3/16	4.76	3/4	19.05	8	7.0%
7/32	5.56	3/4	19.05	8	8.8%
1/4	6.35	3/4	19.05	8	10.8%

Standard hole sizes listed per 6 in (152.4 mm) module. All vacuum holes are centered on the chain.

Classic Sprockets Moulded

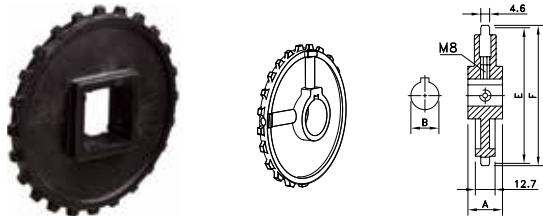

Classic Sprockets Machined

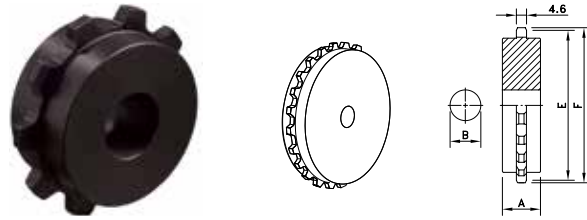

Sprocket Type	Code Number	Number of Teeth	Bore	Pitch Diameter	Outside Diameter	Hub Width
			B	E	F	A
			mm	mm	mm	mm

Classic Sprockets Injection Moulded

Round Bores						
N5936-10T_25MM_1KW2SS_POM	10028485	10	25	62.2	63.5	25
N5936-24T_25MM_1KW2SS_POM	10028491	24	25	147.3	149.2	
N5936-24T_30MM_1KW2SS_POM	10028492	24	30			
N5936-24T_35MM_1KW2SS_POM	10333740	24	35			
N5936-24T_40MM_1KW2SS_POM	10028493	24	40			

Square Bores						
N5936-24T_40MM_S_POM	10013547	24	40	147.3	149.2	25
N5936-24T_50MM_S_POM	10013549	24	50			
N5936-24T_65MM_S_POM	10013551	24	65			
N5936-25T_40MM_S_POM	10027394	25	40	153.4	156.2	25
N5936-25T_65MM_S_POM	10027396	25	65			

Classic Sprockets Machined

Round Bores						
KU5936-10T_20MM_P_PA	10297194	10	20	63.2	63.5	25
KU5936-24T_20MM_P_PA	10296949	24	20	147.3	149.2	
KU5936-31T_20MM_P_PA	10330598	31	20	190.1	193.3	

Split Sprockets Moulded

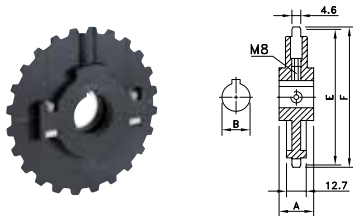

Sprocket Type	Code Number	Number of Teeth	Bore	Pitch Diameter	Outside Diameter	Hub Width
			B	E	F	A
			mm	mm	mm	mm

Split Sprockets Injection Moulded

Round Bores						
NS5936-24T_25MM_1KW_PA	10334028	24	25	147.3	149.2	25
NS5936-24T_30MM_1KW_PA	10334029	24	30			
NS5936-24T_35MM_1KW_PA	10334030	24	35			
NS5936-24T_40MM_1KW_PA	10202084	24	40			

Square Bores						
NS5936-24T_40MM_S_PA	10333806	24	40	147.3	149.2	25

Il nastro Serie 1000 con passo da 1 pollice combina elevate caratteristiche di robustezza con un passo universale, che lo rende estremamente versatile; è idoneo in particolare per l'industria delle bevande, imballaggio e alimentare. Le versioni stampate in base alla larghezza sono disponibili con le guide Positrack per le applicazioni a singola via e le macchine imballatrici. La Serie 1000 può essere equipaggiata con facchini per le applicazioni dell'industria alimentare. Di serie, i nastri vengono forniti in acetalica e polipropilene a basso attrito per il settore delle bevande.

Caratteristiche

- Versatili, passo da 1 pollice e struttura a nervatura rigida trasversale con planarità ottimale e quindi elevate possibilità di movimentazione dei prodotti.
- Il sistema di ritenzione dei perni, insieme al sistema a 2 moduli, rende molto semplice l'installazione e la manutenzione del nastro.
- Bordi esterni arrotondati per un miglioramento dei trasferimenti laterali e migliore movimentazione dei prodotti.
- Il nastro serie 1000 è abbinato ai nastri a catena FTM 1060, FGM 1050 o FT 1050, in modo da creare un abbinamento perfetto tra corsa rettilinea e trasportatori curvilinei.

Programma	
1000 Flat Top (FT)	Superficie chiusa; adatta per contenitori in vetro e PET grazie alla sua elevata resistenza. L'assenza di distanze evita che piccole particelle (vetro) si blocchino sulla superficie del nastro; la superficie completamente chiusa fornisce il supporto massimo per i prodotti trasportati
1000 Flush Grid (FG)	Area aperta al 40%; garantisce il flusso d'acqua e aria ottimale e consente il passaggio dello sporco e di mantenere una superficie di contatto pulita tra i prodotti e il nastro. Ideale anche per la produzione e il trattamento di lattine per bibite
1000 Raised Rib (RR)	Area aperta al 40%; insieme alle speciali piastre ad aste Click-Comb, la superficie nervata consente trasferimenti graduali sui tavoli di accumulo, i depalettizzatori e i tavoli di scarico
1000 Raised Rib narrow (RR)	Area aperta a 13%; adatto per le macchine imballatrici
1000 Raised Rib Railtrack (RRR)	I nastri stretti 1000 RR con Railtrack, per inserimento ottimale sulle guide e configurazione economica del trasportatore
1000 SuperGrip (SG)	Superficie elevata ad attrito elevato per gestire pacchetti su trasportatori inclinati e in discesa. Angoli standard fino a 20°
1000 LBP	Versione per accumulo con rulli a bassa rumorosità, che garantisce la movimentazione ottimale dei prodotti imballati delicati, come vassoi sigillati con e senza fondo di cartone
FreeFlow	Sistema di trasferimento dinamico per l'eliminazione completa della piastre morte con trasferimenti a 90°, creando trasferimenti a spostamento automatico
Positrack	Anse per una guida accurata e affidabile di carichi pesanti e nastri a guida singola, per una movimentazione ottimale dei prodotti
Accessori per i nastri	Facchini per la movimentazione di alimenti ingombranti su trasportatori inclinati e in discesa; pettini di trasferimento RR 1000 e RR 1000 strette per trasferimenti precisi



Bottle conveyor with FT1000 DRY-PT MatTop® Chain



Trasportatore di bottiglie con nastro FTDP1000 XLG

FlatTop 1001-84MM



Chain Type	Material	Code Number	Working Load (max)	Weight	Backflex Radius (min)	Temperature Range °C	
			N/m / lbs	kg/m / lbs/ft	mm / in	Dry	Wet
DRY-PT1001FT-84MM_MTW_PT-1DP	DRY-PT	10522806	337 / 1500	0.40 / 0.59	1.00 / 25.4	4 to 80 / 4 to 65	
PSX1001FT-84MM_MTW_PT-1DP	PSX	10522807	337 / 1500	0.40 / 0.59	1.00 / 25.4		
XLG1001FT-84MM_MTW_PT-1DP	XLG	10522808	337 / 1500	0.40 / 0.59	1.00 / 25.4		
HP1001FT-84MM_MTW_PT-1DP	HP	10522812	337 / 1500	0.40 / 0.59	1.00 / 25.4		
DKA1001FT-84MM_MTW_PT-1DP	DKA	10522795	337 / 1500	0.40 / 0.59	1.00 / 25.4		

Flush Grid 1001-84MM



Chain Type	Material	Code Number	Working Load (max)	Weight	Backflex Radius (min)	Temperature Range °C	
			N/m / lbs	kg/m / lbs/ft	mm / in	Dry	Wet
DRY-PT1001FG-84MM_MTW_PT-1DP	DRY-PT	10522829	337 / 1500	0.38 / 0.57	1.00 / 25.4	4 to 80 / 4 to 65	
PSX1001FG-84MM_MTW_PT-1DP	PSX	10522830	337 / 1500	0.38 / 0.57	1.00 / 25.4		
XLG1001FG-84MM_MTW_PT-1DP	XLG	10522831	337 / 1500	0.38 / 0.57	1.00 / 25.4		
HP1001FG-84MM_MTW_PT-1DP	HP	10522834	337 / 1500	0.38 / 0.57	1.00 / 25.4		
DKA1001FG-84MM_MTW_PT-1DP	DKA	10522828	337 / 1500	0.38 / 0.57	1.00 / 25.4		

FlatTop 1000

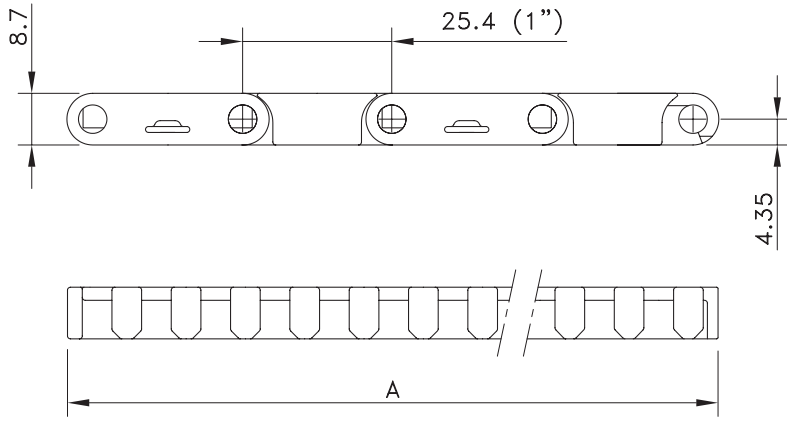
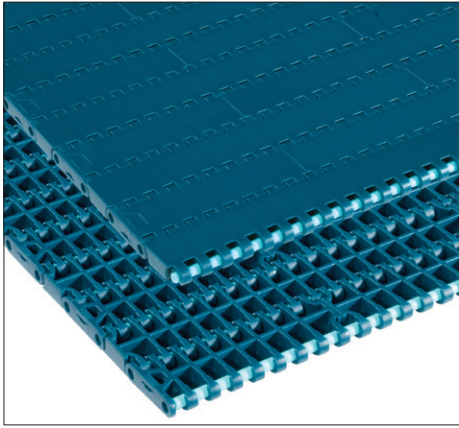

Assembly	Belt Type	Code Number*	Temperature range °C		Working Load (max.) N/m (21°C)	Weight kg/m ²	Backflex Radius (min.) mm
			Dry	Wet			
XLG-Acetal with Polypropylene Pins (84 has PBT pins)							
Standard	FT 1000 XLG	817.30.xx	4 to 80	4 to 65	22000	6.50	25
Double positrack	FTDP 1000 XLG	873.27.xx					
Positrack 2 sides, freeflow 1 side	FFTP 1000 XLG 2xP	873.07.xx					
PSX Advanced Performance Polymer Alloy with PBT pins							
Standard	FT 1000 PSX	873.78.xx	-30 to +80	up to 65	22000	6.50	25
Double positrack	FTDP 1000 PSX	873.79.xx					
Positrack 2 sides, freeflow 1 side	FFTP 1000 PSX 2xP	873.82.xx					
XP-Polypropylene with Polypropylene Pins							
Standard	FT 1000 XP	818.30.xx	4 to 104	4 to 104	11000	4.25	25
Double positrack	FTDP 1000 XP	873.29.xx					
WLT-Polyethylene with Polyethylene Pins							
Standard	WLT 1000 FT	812.60.xx	-70 to +35	-70 to +35	5000	4.60	25
WHT-Polypropylene with Polypropylene Pins							
Standard	WHT 1000 FT	811.80.xx	4 to 104	4 to 104	11000	4.30	25
WSM-Acetal with Polypropylene Pins							
Standard	WSM 1000 FT	815.70.xx	4 to 80	4 to 65	22000	6.50	25
Double positrack	WSM 1000 FTDP	873.28.xx					
DRY-PT Advanced Performance Polymer Alloy with PBT pins							
Standard	FT 1000 DRY-PT	DRYPT1000FT	-30 to 80	up to 65	22000	6.50	25
Double positrack	FTDP 1000 DRY-PT	DRYPT1000FT					

* In code numbers xx corresponds with the belt width (A), starting with 10 for 85 mm, 11 for 170 mm and so on with 85 mm increments, or optionally 5 mm, up to 6120 mm; see also page 208. If you need flights, describe the belt by choosing from the required options listed in the 2nd column of the table:

Material	XLG, WLT, WHT or WSM	
Belt type	1000 FT or 1000 FTDP	(Double) Positrack not possible for WLT, BLT and WHT
Width (A)	KM - in mm	Belts with flights have a minimal width of 130 mm with 10 mm increments
Flights	F3 or F2 or F1	Standard height of 3", 2", 1" or special height in mm
Pitch between flights	T..P	Flights on every .. th row (must correspond to an even number of rows)
Flight side-indent	N.. (in mm)	Minimal 40 mm with 5 mm increments

Example: WSM1000FT-430MM_F50MM_T6P_N45MM_PT-1DP is a 1000 Flat Top belt with Double Positrack, made of white acetal, special width 430 mm, special 50 mm high flights on every 6th row at 45 mm from the sides

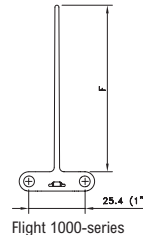
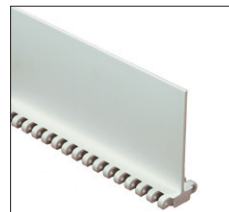
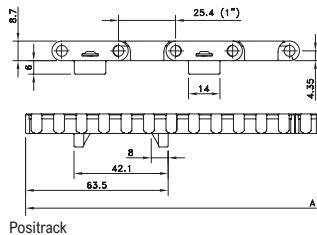
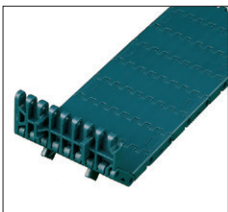

Flush Grid 1000

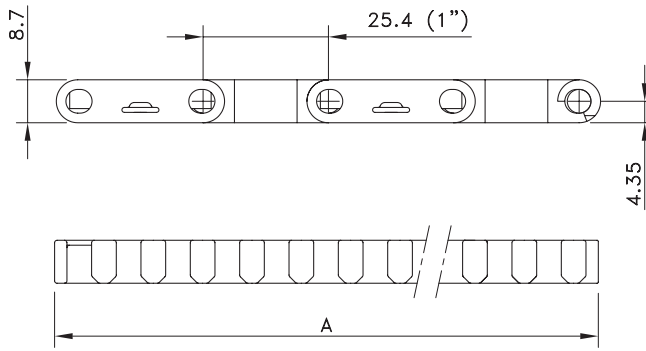
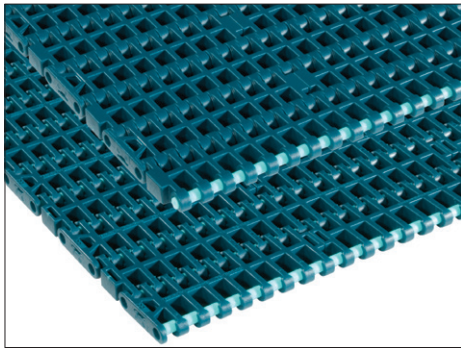

Assembly	Belt Type	Code Number*	Temperature range °C		Working Load (max.) N/m (21°C)	Weight kg/m ²	Backflex Radius (min.) mm
			Dry	Wet			
XLG-Acetal with Polypropylene Pins (84 has PBT pins)							
Standard	FG 1000 XLG	817.40.xx	4 to 80	4 to 65	22000	5.40	25
Double Positrack	FGDP 1000 XLG	874.43.xx					
Positrack 1 side, freeflow 1 side	FFGP 1000 XLG 1xP	874.08.xx					
Positrack 2 sides, freeflow 1 side	FFGP 1000 XLG 2xP	874.07.xx					
PSX Advanced Performance Polymer Alloy with PBT pins							
Standard	FG 1000 PSX	874.63.xx	-30 to +80	up to 65	22000	5.40	25
Double Positrack	FGDP 1000 PSX	874.64.xx					
Positrack 1 side, freeflow 1 side	FFGP 1000 PSX 1xP	874.68.xx					
Positrack 2 sides, freeflow 1 side	FFGP 1000 PSX 2xP	874.69.xx					
XP-Polypropylene with Polypropylene Pins							
Standard	FG 1000 XP	818.40.xx	4 to 104	4 to 104	11000	3.53	25
Double positrack	FGDP 1000 XP	874.45.xx					
WLT-Polyethylene with Polyethylene Pins							
Standard	WLT 1000 FG	812.70.xx	-70 to +35	-70 to +35	5000	3.70	25
WHT-Polypropylene with Polypropylene Pins							
Standard	WHT 1000 FG	811.90.xx	4 to 104	4 to 104	11000	3.50	25
BHT-Polypropylene with Polypropylene Pins							
Standard	BHT 1000 FG	810.08.xx	4 to 104	4 to 104	11000	3.50	25
WSM-Acetal with Polypropylene Pins							
Standard	WSM 1000 FG	815.80.xx	4 to 80	4 to 65	22000	5.40	25
Double positrack	WSM 1000 FGDP	874.44.xx					
SMB-Acetal with Polypropylene Pins							
Standard	SMB 1000 FG	810.07.xx	4 to 80	4 to 65	22000	5.40	25

* In code numbers xx corresponds with the belt width (A), starting with 10 for 85 mm, 11 for 170 mm and so on with 85 mm increments, or optionally 5 mm, up to 6120 mm.

If you need flights, describe the belt by choosing from the required options listed in the 2nd column of the table:

Material	WLT or BLT or WHT or BHT or WSM or SMB	
Belt type	1000 FG or 1000 FGDP	(Double) Positrack not possible for WLT, BLT, WHT, BHT and SMB
Width (A)	KM - in mm	Belts with flights have a minimal width of 130 mm with 10 mm increments
Flights	F3 or F2 or F1	Standard height of 3", 2", 1" or special height in mm
Pitch between flights	T..P	Flights on every .. th row (must correspond to an even number of rows)
Flight side-indent	N.. (in mm)	Minimal 40 mm with 5 mm increments

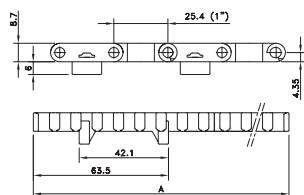
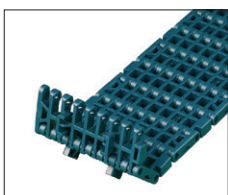

Positrack

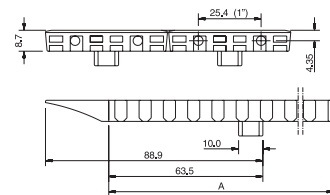
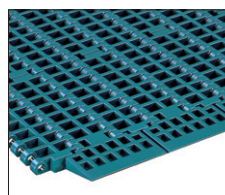

Freeflow 1000-series

Supergrip 1000

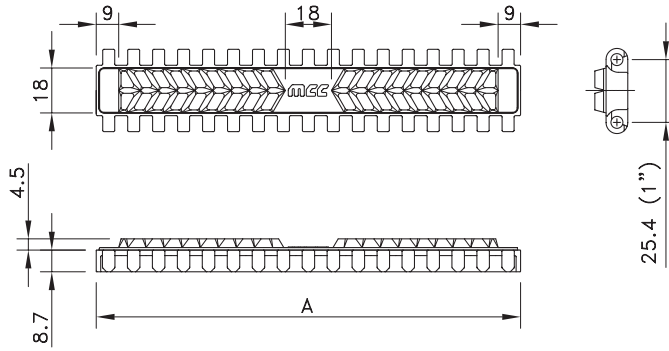
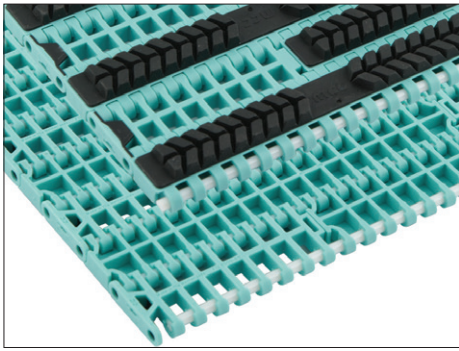

Assembly	Belt Type	Code Number*	Width A	Temperature range °C		Working Load (max.) N/m (21°C)	Weight kg/m ²	Backflex Radius (min.) mm
			mm	Dry	Wet			
XP-Polypropylene with PBT Pins								
Standard	SG 1000 XP 170	875.00.11	170	4 to 65	4 to 65	11000	5.00	30
	SG 1000 XP 255	875.00.12	255				5.33	
	SG 1000 XP 340	875.00.13	340				5.50	
	SG 1000 XP 425	875.00.14	425				5.60	
	SG 1000 XP 510	875.00.15	510				5.66	
	SG 1000 XP 595	875.00.16	595				5.71	
	SG 1000 XP 680	875.00.17	680				5.75	
Double positrack	SGDP 1000 XP 170	875.54.11	170	4 to 65	4 to 65	11000	5.00	30
	SGDP 1000 XP 255	875.54.12	255				5.33	
	SGDP 1000 XP 340	875.54.13	340				5.50	
	SGDP 1000 XP 425	875.54.14	425				5.60	
	SGDP 1000 XP 510	875.54.15	510				5.66	
	SGDP 1000 XP 595	875.54.16	595				5.71	
	SGDP 1000 XP 680	875.54.17	680				5.75	
XLG-Acetal with Polypropylene Pins								
Standard	SG 1000 XLG 170	875.30.11	170	4 to 65	4 to 65	19000	7.34	30
	SG 1000 XLG 255	875.30.12	255				7.70	
	SG 1000 XLG 340	875.30.13	340				7.88	
	SG 1000 XLG 425	875.30.14	425				7.99	
	SG 1000 XLG 510	875.30.15	510				8.06	
	SG 1000 XLG 595	875.30.16	595				8.12	
	SG 1000 XLG 680	875.30.17	680				8.16	
Double positrack	SGDP 1000 XLG 170	875.59.11	170	4 to 65	4 to 65	19000	7.34	30
	SGDP 1000 XLG 255	875.59.12	255				7.70	
	SGDP 1000 XLG 340	875.59.13	340				7.88	
	SGDP 1000 XLG 425	875.59.14	425				7.99	
	SGDP 1000 XLG 510	875.59.15	510				8.06	
	SGDP 1000 XLG 595	875.59.16	595				8.12	
	SGDP 1000 XLG 680	875.59.17	680				8.16	
WHT-Polypropylene with PBT Pins								
Standard	SG 1000 WHT 255	875.25.12	255	4 to 104	4 to 104	11000	5.33	30
	SG 1000 WHT 340	875.25.13	340				5.50	
	SG 1000 WHT 425	875.25.14	425				5.60	
	SG 1000 WHT 510	875.25.15	510				5.66	
	SG 1000 WHT 595	875.25.16	595				5.71	
	SG 1000 WHT 680	875.25.17	680				5.75	

Special widths begin at 85 mm with 5 mm increments. Wider belts are available upon request.

Standard 100% rubber; other percentages can be supplied upon request.

Rubber top is a black elastomere, with a hardness of 40 (XP) or 50 (XLG) or 60 (WHT material has a white elastomere Rubber top) shore A.

Raised Rib 1000

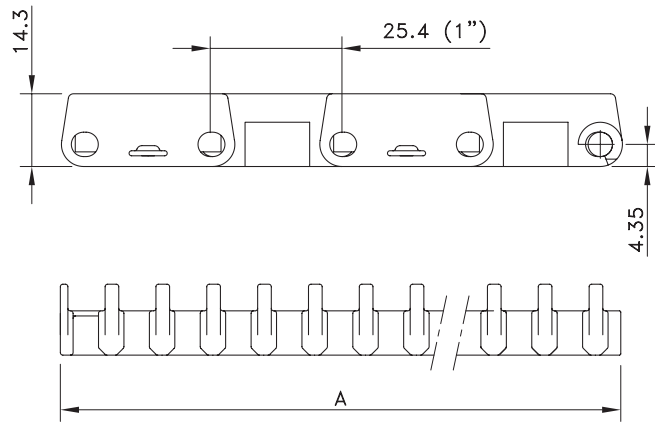
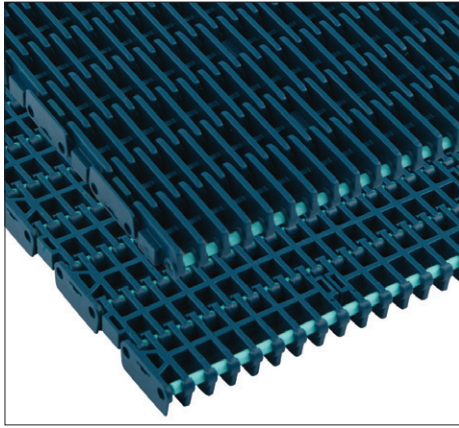

Assembly	Belt Type	Code Number*	Temperature range °C		Working Load (max.) N/m (21°C)	Weight kg/m ²	Backflex Radius (min.) mm
			Dry	Wet			
XLG-Acetal with Polypropylene Pins							
Standard	XLG1000RR	817.10.xx	4 to 80	4 to 65	22000	7.95	50
AS-Acetal with Polypropylene Pins							
Standard	AS1000RR	814.10.xx	4 to 80	–	130 00	7.47	50

* In code numbers xx corresponds with the belt width (A), starting with 10 for 85 mm, 11 for 170 mm and so on with 85 mm increments, up to 6120 mm; see also page 208. Special widths begin at 85 mm with 5 mm increments.

Fingerplates Raised Rib

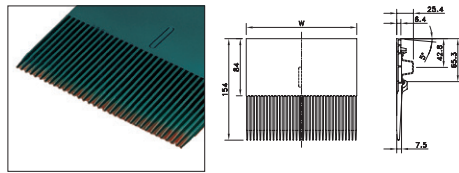

Type	Code Number	Weight	Width W	Length
		kg	mm	mm
XLG-Acetal				
TRAN PLT COMB XLG1000 154X170MM	10146446	0.14	168	154
TRAN PLT COMB XLG1000 154X85MM	10146445	0.07	83	
AS-Acetal				
TRAN PLT COMB AS1000-154X170MM	10361707	0.13	168	154
TRAN PLT COMB AS1000-154X85MM	10361706	0.06	83	

Profiles for Fingerplates

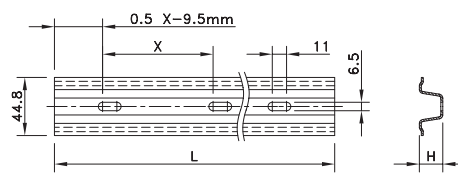

Type	Code Number	Length L	Weight kg	Height H mm	Number of Pitches	Pitch X	
		mm				mm	inch
Stainless Steel							
PROF.FOR COMB H=18 L=3052 MM	10724983	3052	2.46	18	35	85.0	3.35

Raised Rib 1000 Narrow

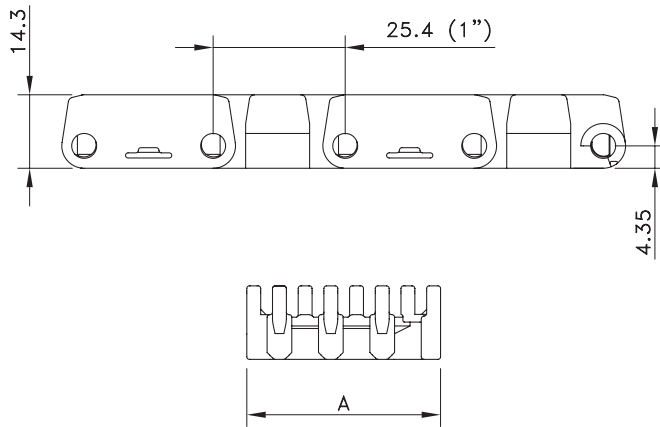
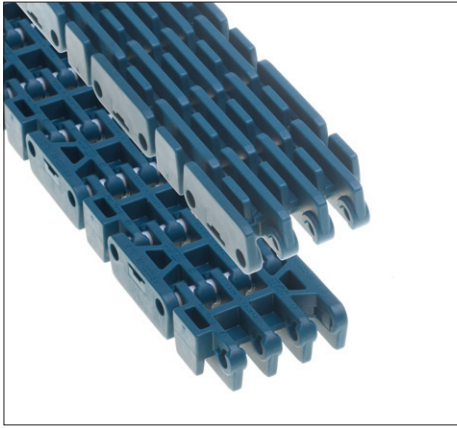

Assembly	Belt Type	Code A Number	Width A	Temperature range °C		Working Load (max.) N/m (21°C)	Weight kg/m ²	Backflex Radius (min.) mm
			mm	Dry	Wet			
XLG-Acetal with PBT Pins								
Standard	XLG1000RR-28MM_MTW	10147974	28	-30 to +80	up to 65	400	0.35	50
	XLG1000RR-38MM_MTW	10147972	38	-30 to +80	up to 65	400	0.39	
	XLG1000RR-48MM_MTW	10147973	48	-30 to +80	up to 65	600	0.48	

Standard length: 6.096 m - 20 feet.

Raised Rib 1000 Railtrack Narrow

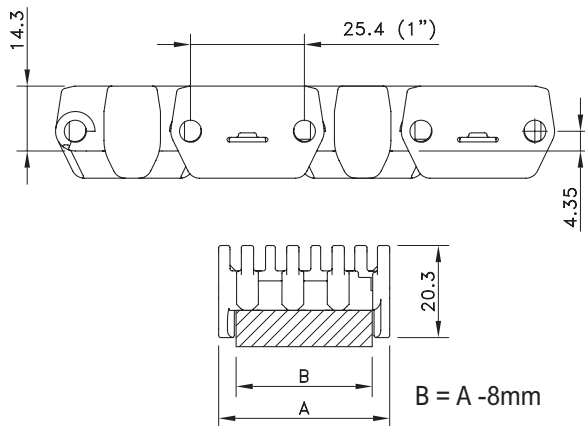
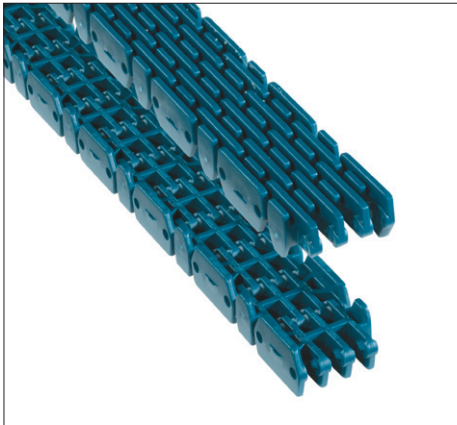

Assembly	Belt Type	Code Number	Width A	Temperature range °C		Working Load (max.) N/m (21°C)	Weight kg/m ²	Backflex Radius (min.) mm
			mm	Dry	Wet			
XLG-Acetal with PBT Pins								
Standard	XLG1000RRR-28MM_MTW	10147971	28	-30 to +80	up to 65	200	0.33	50
	XLG1000RRR-38MM_MTW	10147968	38	-30 to +80	up to 65	400	0.43	
	XLG1000RRR-48MM_MTW	10147969	48	-30 to +80	up to 65	600	0.53	
	XLG1000RRR-58MM_MTW	10147970	58	-30 to +80	up to 65	800	0.62	

Standard length: 6.096 m - 20 feet.

Fingerplates Raised Rib Narrow

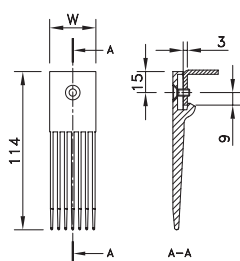

Type	Code Number	Weight	Width W	Length
		kg	mm	mm
XLG-Acetal				
TRAN PLT COMB XLG1000 114X23MM	10146450	0.01	23	114
TRAN PLT COMB XLG1000 114X33MM	10146447	0.02	33	
TRAN PLT COMB XLG1000 114X43MM	10146448	0.02	43	
TRAN PLT COMB XLG1000 114X53MM	10146449	0.03	53	

LBP 1000

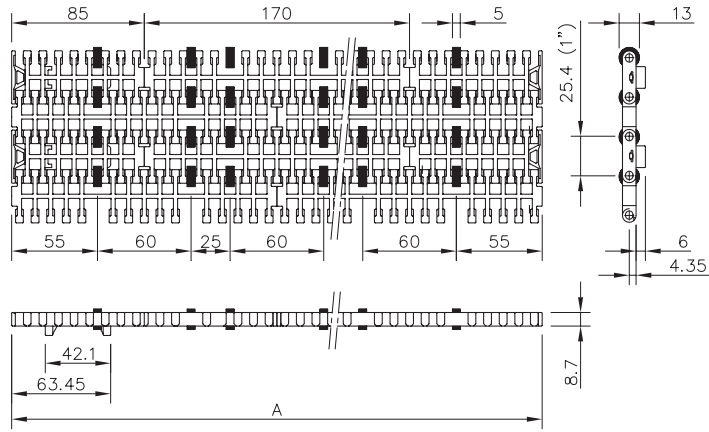
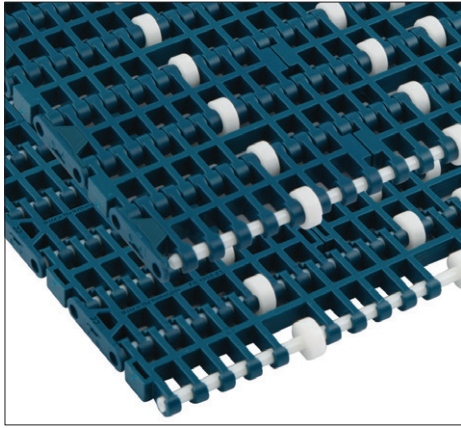

Assembly	Belt Type	Code Number*	Temperature range °C		Working Load (max.) N/m (21°C)	Weight kg/m ²	Backflex Radius (min.) mm
			Dry	Wet			
XLG-Acetal with PBT Pins							
Double Positrack	LBPDP 1000 XLG	874.47.xx	4 to 80	4 to 65	19400	5.40	25

* In code numbers xx corresponds with the belt width (A), starting with 11 for 170 mm, 12 for 255 mm and so on with 85 mm increments up to 6120 mm; see also page 211.

Split Sprockets Wide Hub

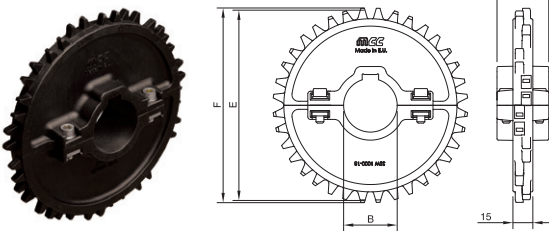

Sprocket Type	Code Number	Number of Teeth	Bore	Pitch Diameter	Outside Diameter	Hub Width
			B	E	F	A
Round Bores						
NS1000-16T_30MM_1KW_PA	10017957	16	30 mm	130.2	130.6	39
NS1000-16T_35MM_1KW_PA	10027358	16	35 mm			
NS1000-16T_40MM_1KW_PA	10017956	16	40 mm			
NS1000-18T_30MM_1KW_PA	10017960	18	30 mm	146.3	146.8	
NS1000-18T_35MM_1KW_PA	10027359	18	35 mm			
NS1000-18T_40MM_1KW_PA	10017959	18	40 mm			
NS1000-20T_30MM_1KW_PA	10027360	20	30 mm	162.4	163.1	
NS1000-20T_35MM_1KW_PA	10017965	20	35 mm			
NS1000-20T_40MM_1KW_PA	10017966	20	40 mm			
NS1000-16T_1-1/2IN_1KW_PA	10017958	16	1.5"	130.2	130.6	
NS1000-18T_1-1/2IN_1KW_PA	10017962	18	1.5"	146.3	146.8	
NS1000-20T_1-1/2IN_1KW_PA	10017967	20	1.5"	162.4	163.1	
Square Bores						
NS1000-16T_40MM_S_PA	10027464	16	40 mm	130.2	130.6	39
NS1000-18T_40MM_S_PA	10017961	18	40 mm	146.3	146.8	
NS1000-20T_40MM_S_PA	10027465	20	40 mm	162.4	163.1	
NS1000-16T_1-1/2IN_S_PA	10026583	16	1.5"	130.2	130.6	
NS1000-18T_1-1/2IN_S_PA	10017964	18	1.5"	146.3	146.8	
NS1000-20T_1-1/2IN_S_PA	10017968	20	1.5"	162.4	163.1	

For wide hub sprockets with round bore one keyway is sufficient.

For humid, hot applications like pasteurizing, special sprockets are available; see next page.

Classic Sprockets

Classic Sprockets for Humid, Hot Applications like Pasteurizing

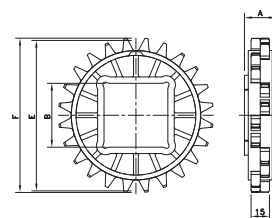
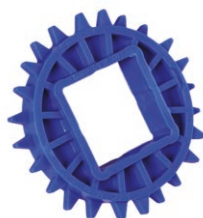
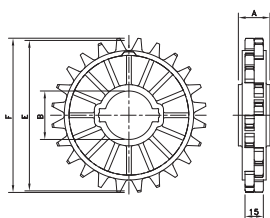

Sprocket Type	Code Number	Number of Teeth	Bore	Pitch Diameter	Outside Diameter	Hub Width
			B	E	F	A
Round Bores						
mm/inch						
mm						
mm						
Round Bores						
N1000-12T_30MM_2KW_PA	10334262	12	30 mm	98.1	96.5	20
N1000-12T_40MM_2KW_PA	10334263	12	40 mm			
N1000-12T_50MM_2KW_PA	10334264	12	50 mm			
N1000-18T_30MM_2KW_PA	10148154	18	30 mm	146.3	145.9	
N1000-18T_35MM_2KW_PA	10334268	18	35 mm			
N1000-18T_40MM_2KW_PA	10148153	18	40 mm			
N1000-18T_45MM_2KW_PA	10334270	18	45 mm			
N1000-18T_50MM_2KW_PA	10334271	18	50 mm			
N1000-18T_65MM_2KW_PA	10334272	18	65 mm			30
N1000-20T_35MM_2KW_PA	10334279	20	35 mm	162.4	161.7	20
N1000-20T_40MM_2KW_PA	10334280	20	40 mm			
N1000-20T_50MM_2KW_PA	10148159	20	50 mm			
N1000-12T_1IN_2KW_PA	10327925	12	1.0"	98.1	96.5	
N1000-18T_1-1/2IN_2KW_PA	10148156	18	1.5"			
N1000-18T_2IN_2KW_PA	10327942	18	2.0"			
N1000-20T_1IN_2KW_PA	10148162	20	1.0"	162.4	161.7	
N1000-20T_1-1/2IN_2KW_PA	10148161	20	1.5"			
Square Bores						
N1000-18T_40MM_S_PA	10148155	18	40 mm	146.3	145.9	20
N1000-18T_60MM_S_PA	10334274	18	60 mm			
N1000-18T_65MM_S_PA	10334275	18	65 mm			
N1000-20T_40MM_S_PA	10148160	20	40 mm	162.4	161.7	20
N1000-20T_60MM_S_PA	10334283	20	60 mm			
N1000-20T_65MM_S_PA	10334284	20	65 mm			
N1000-12T_1-1/2IN_S_PA	10148152	12	1.5"	98.1	96.5	20
N1000-18T_1-1/2IN_S_PA	10148158	18	1.5"	146.3	145.9	
N1000-20T_1-1/2IN_S_PA	10148163	20	1.5"	162.4	161.7	
Classic Sprockets for Humid, Hot Applications like Pasteurizing						
Square Bores						
N1000-12T_40MM_S_POM	10148119	12	40 mm	98.1	96.5	20
N1000-18T_40MM_S_POM	10148120	18	40 mm	146.3	145.9	20
N1000-18T_60MM_S_POM	10334266	18	60 mm			
N1000-20T_40MM_S_POM	10334276	20	40 mm	162.4	161.7	20
N1000-20T_60MM_S_POM	10334277	20	60 mm			

Il nastro per carichi pesanti con passo da 1 pollice Serie 1005 combina uno spessore da ½ di pollice con design robusto e un passo universale, molto versatile per le applicazioni nell'industria delle bevande, della produzione del vetro e dell'imballaggio. Di serie, i nastri vengono forniti in acetale a basso attrito, in poliammide e polipropilene estremamente resistente all'usura.

Caratteristiche

- La robusta struttura del nastro e l'elevata resistenza soddisfano le applicazioni più esigenti nell'industria delle bevande, della produzione del vetro e dell'imballaggio.
- Il rivoluzionario sistema di ritenzione dei perni Easy Lock, insieme al sistema a 2 moduli, rende molto semplice l'installazione e la manutenzione del nastro.
- Bordi esterni arrotondati per un miglioramento dei trasferimenti laterali e migliore movimentazione dei prodotti.
- Le posizioni fisse delle ruote di traino da 85 mm migliorano le proprietà di traino e contribuiscono alla standardizzazione della struttura del trasportatore.
- Munito di perni in poliestere impermeabili (PBT) in modo da fornire le migliori prestazioni possibili nel lungo termine.
- I nastri serie 1005 sono abbinati ai nastri a catena FTM 1055, o FT 1055, in modo da creare un abbinamento perfetto tra corsa rettilinea e trasportatori curvilinei.

Programma	
1005 Flat Top (FT)	Superficie chiusa; idonei per le applicazioni di movimentazione di vetri per carichi pesanti e altri ambienti abrasivi
1005 SuperGrip (SG)	Versione con superficie gommata ad alto attrito per la movimentazione di pacchetti su trasportatori inclinati, in discesa e di misurazione; angoli standard fino a 20°. La speciale struttura del profilo di gomma le rende idonei anche per la movimentazione delle cassette
1005 XLBP	Versione con contropressione estremamente bassa con rulli poco rumorosi, e perni dei rulli sempre fissi, che migliorano la sicurezza dell'ambiente e garantiscono una movimentazione ottimale di prodotti imballati delicati, come ad esempio vassoi avvolti in plastica termoretraibile con o senza fondo in cartone (si raccomanda l'utilizzo di guide di scorrimento in materiale ULF)
FreeFlow	Sistema di trasferimento dinamico per l'eliminazione completa della piastre morte con trasferimenti a 90°, creando trasferimenti a spostamento automatico
Positrack	Alette per una guida accurata e sicura in presenza di carichi pesanti e nastri a guida singola, per una movimentazione ottimale dei prodotti

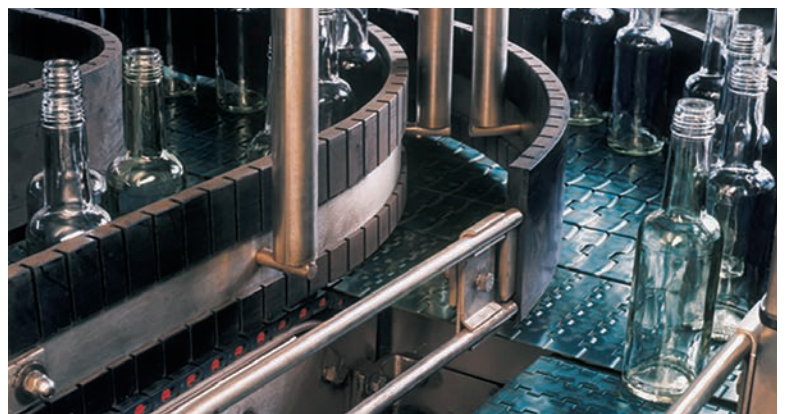

FlatTop® 1005

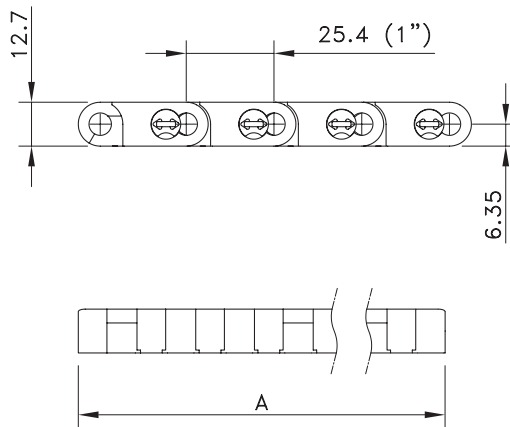
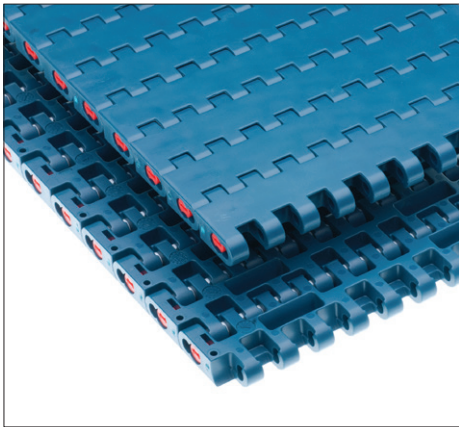

Assembly	Belt Type	Code Number*	Temperature range °C		Working Load (max.) N/m (21°C)	Weight kg/m ²	Backflex Radius (min.) mm
			Dry	Wet			
XLG-Acetal with PBT Pins							
Standard	FT 1005 XLG	877.00.xx	-40 to +80	up to 65	35000	13.50	25
Double positrack	FTDP 1005 XLG	877.01.xx					
Double positrack, freeflow	FFDTP 1005 XLG	877.02.xx					
Mould to width (MTW)	FT 1005 XLG K450 MTW	877.00.00					
MTW double positrack	FTDP 1005 XLG K450 MTW	877.01.00					
PSX Advanced Performance Polymer Alloy with PBT Pins							
Standard	FT 1005 PSX	877.25.xx	-40 to +80	up to 65	35000	13.50	25
Double positrack	FTDP 1005 PSX	877.26.xx					
BWX-Polyamide Composite with PBT Pins							
Standard	FT 1005 BWX	877.27.xx	-40 to +80	not recommended	35000	13.50	25
Double positrack	FTDP 1005 BWX	877.28.xx					
Mould to width (MTW)	FT 1005 BWX K450 MTW	877.14.00					
MTW double positrack	FTDP 1005 BWX K450 MTW	877.15.00					
XP-Polypropylene with PBT Pins							
Standard	FT 1005 XP	877.05.xx	4 to 65	4 to 65	17500	9.00	25
Double positrack	FTDP 1005 XP	877.06.xx					

* In code numbers xx corresponds with the belt width (A), starting with 10 for 85 mm, 11 for 170 mm and so on in steps of 85 mm up to 6120 mm. Other sizes upon request. See page 208 for all code numbers.

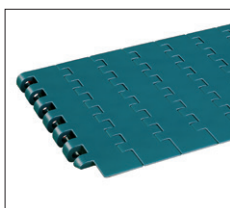

Flat Top 1005 heavy duty belt with integrated FreeFlow

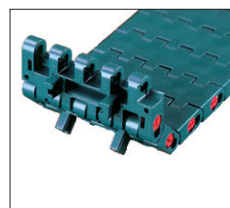
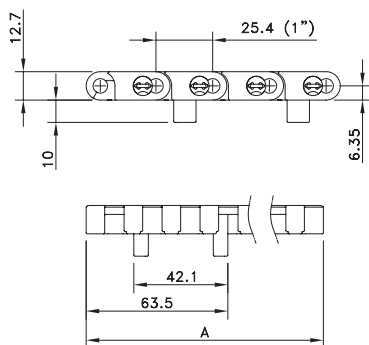

Flat Top 1005 heavy duty belt with Positrack

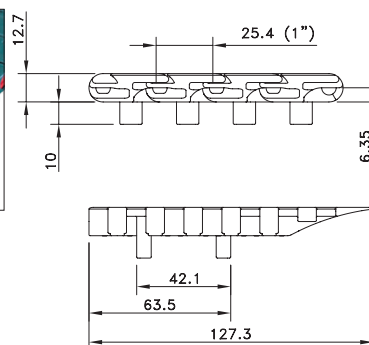

The double Positrack lugs are positioned on one side of the belt for precise transfer possibilities.

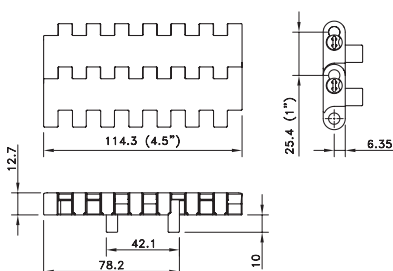

1005 Belt mould to width with double Positrack

Supergrip 1005

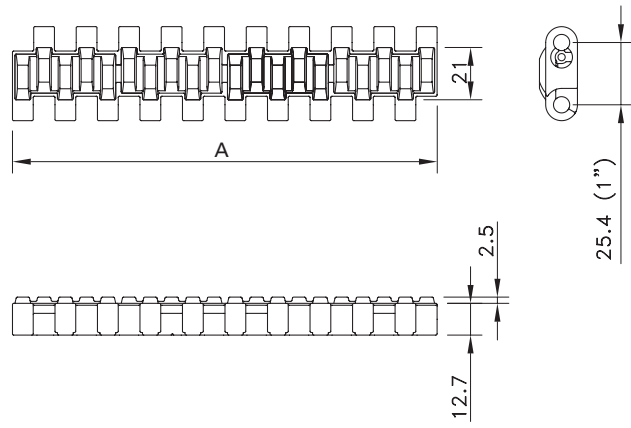
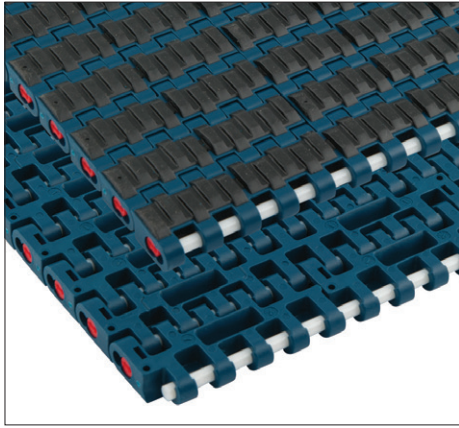

Assembly	Belt Type	Code Number*	Temperature range °C		Working Load (max.) N/m (21°C)	Weight kg/m ²	Backflex Radius (min.) mm
			Dry	Wet			
XLG-Acetal with PBT Pins							
Standard	SG 1005 XLG	877.50.xx	-40 to +65	up to +65	35000	14.00	25
Double Positrack	SGDP 1005 XLG	877.51.xx					
XP-Polypropylene with PBT Pins							
Standard	SG 1005 XP	877.64.xx	4 to 65	4 to 65	17500	10.00	25
Double Positrack	SGDP 1005 XP	877.66.xx					
TCF-Tough Composite Friction Material with Stainless Steel Pins							
Standard	SG 1005 TCF	877.71.xx	-18 to +82	-18 to +60	32000	19.30	25
Double Positrack	SGDP 1005 TCF	877.72.xx					

* In code numbers xx corresponds with the belt width (A), starting with 11 for 170 mm, 12 for 255 mm and so on with 85 mm increments up to 6120 mm; see also page 208. Standard 100% rubber; other percentages and sizes on request. Rubber top is a black elastomere, with a hardness of 40 (XP) or 50 (XLG) or 55 (TCF) shore A.

1005-Series

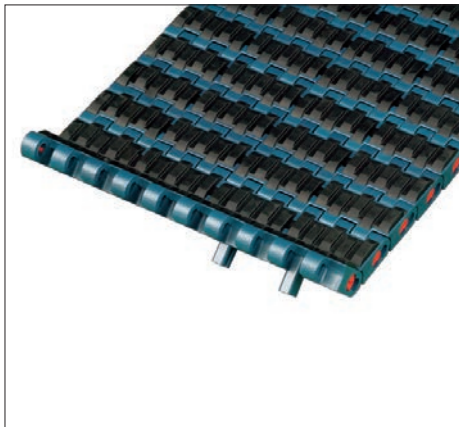

1005 supergrip belt with double positrack on one side of the belt

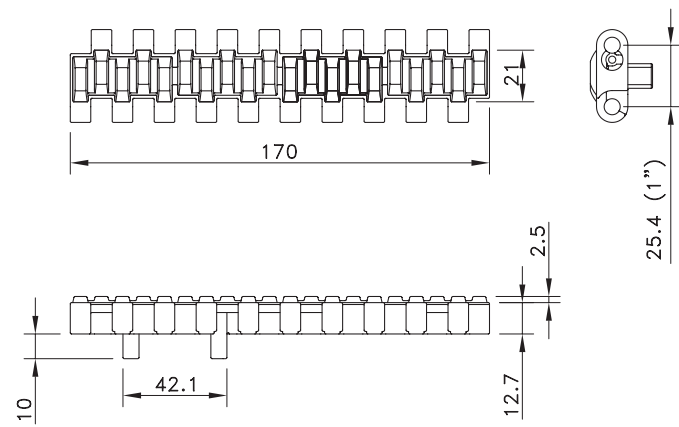

Supergrip Side-Indent 1005

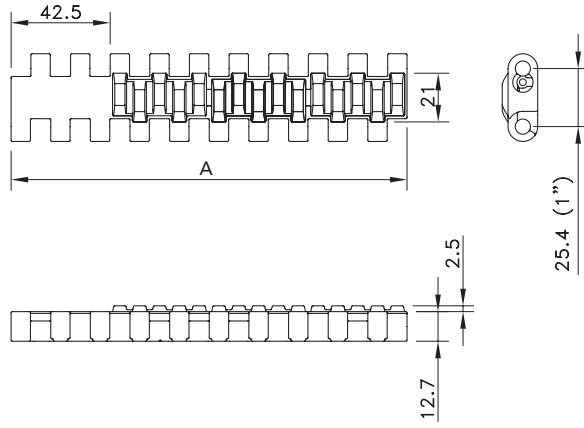
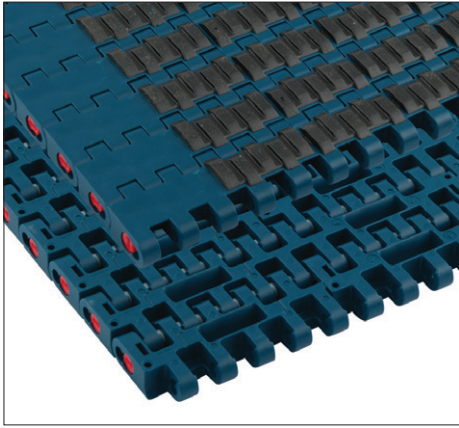

Assembly	Belt Type	Code Number*	Temperature range °C		Working Load (max.) N/m (21°C)	Weight kg/m ²	Backflex Radius (min.) mm
			Dry	Wet			
XLG-Acetal with PBT Pins							
Standard	SGS 1005 XLG	877.52.xx	-40 to +65	up to 65	35000	14.00	25
Double Positrack	SGSDP 1005 XLG	877.53.xx					
XP-Polypropylene with PBT Pins							
Standard	SGS 1005 XP	877.65.xx	4 to 65	4 to 65	17500	10.00	25
Double Positrack	SGSDP 1005 XP	877.67.xx					

* In code numbers xx corresponds with the belt width (A), starting with 12 for 255 mm, 13 for 340 mm and so on with 85 mm increments up to 6120 mm; see also page 208. Standard 100% rubber; other percentages and sizes on request.
 Rubber top is a black elastomere, with a hardness of 40 (XP) or 50 (XLG) shore A.
 A center indent of 85 mm is possible from 765 mm belt width, with steps of 170 mm.

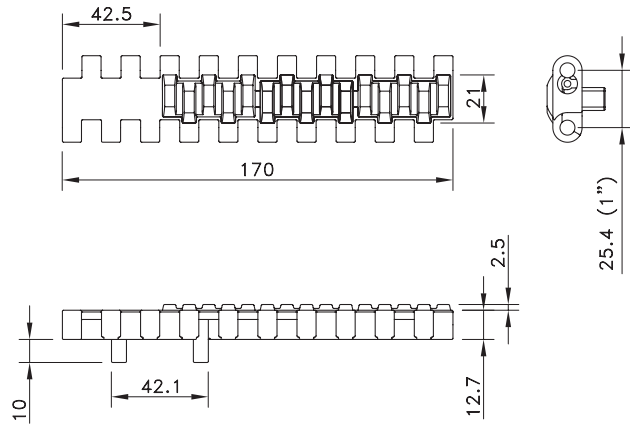
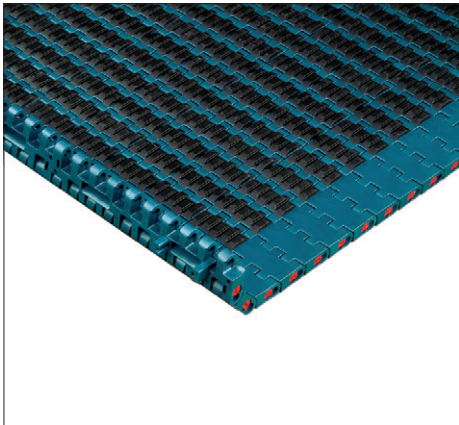

1005 Supergrip Side-Indent belt with Double Positrack

XLBP 1005

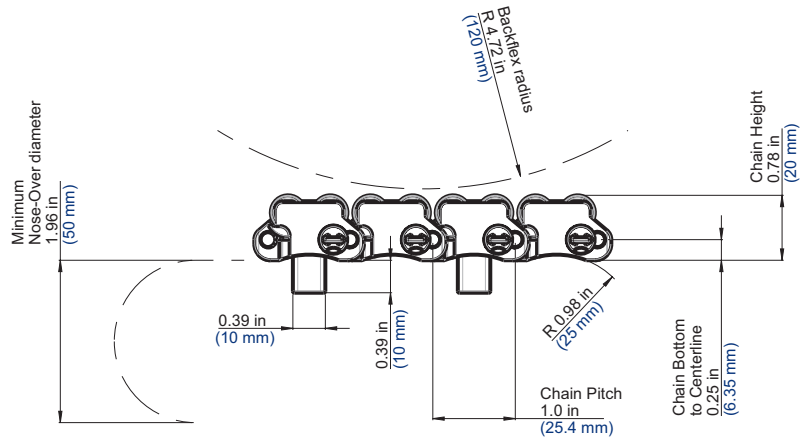

Assembly	Belt Type	Code Number*	Temperature range °C		Working Load (max.) N/m (21°C)	Weight kg/m ²	Backflex Radius (min.) mm
			Dry	Wet			
XLA-Acetal with PBT Pins							
Standard	XLA1005XLBP	877.29.xx	-40 to +80	1 to 65	14000	18	120
Double Positrack	XLA1005XLBP_MM_PT-L	877.30.xx					

* In code numbers xx corresponds with the belt width (A), starting with 11 for 170 mm, 12 for 255 mm and so on in steps of 85 mm up to 6120 mm. Other sizes upon request. See page 208 for all code numbers.

Split Sprockets and Idlers Machined

Split Sprockets and Idlers Moulded

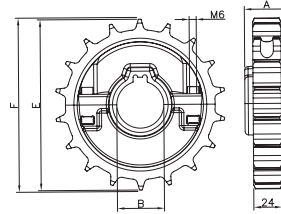
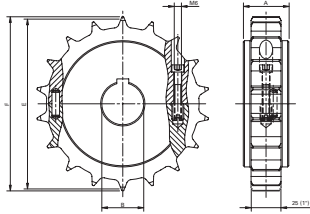

Sprocket Type	Code Number	Number of Teeth	Bore	Pitch Diameter	OutKUSde Diameter	Hub Width
			B	E	F	A
			mm/inch	mm	mm	mm

Split Sprockets and Idlers Machined

Sprockets with Round Bores

KUS1005-18T_30MM_1KW_PA	10148133	18	30 mm	146.3	145.3	38
KUS1005-18T_40MM_1KW_PA	10148132	18	40 mm			
KUS1005-21T_30MM_1KW_PA	10331515	21	30 mm	170.4	169.7	
KUS1005-21T_40MM_1KW_PA	10332229	21	40 mm			
KUS1005-18T_1IN_1KW_PA	10326649	18	1.0"	146.3	145.3	
KUS1005-18T_1-1/2IN_1KW_PA	10148136	18	1.5"			
KUS1005-21T_1IN_1KW_PA	10326647	21	1.0"	170.4	169.7	
KUS1005-21T_1-1/2IN_1KW_PA	10326987	21	1.5"			

Idlers

KUS1005-18T_30MM_I_PA	10148135	18	30 mm	146.3	145.3	38
KUS1005-18T_40MM_I_PA	10148134	18	40 mm			
KUS1005-21T_30MM_I_PA	10331517	21	30 mm	170.4	169.7	
KUS1005-21T_40MM_I_PA	10332231	21	40 mm			
KUS1005-18T_1IN_I_PA	10326650	18	1.0"	146.3	145.3	
KUS1005-18T_1-1/2IN_I_PA	10148138	18	1.5"			
KUS1005-21T_1IN_I_PA	10326648	21	1.0"	170.4	169.7	
KUS1005-21T_1-1/2IN_I_PA	10326988	21	1.5"			

Sprockets with Square Bores

KUS1005-18T_40MM_S_PA	10148130	18	40 mm	146.3	145.3	38
KUS1005-21T_40MM_S_PA	10332228	21	40 mm	170.4	169.7	
KUS1005-18T_1-1/2IN_S_PA	10148131	18	1.5"	146.3	145.3	
KUS1005-21T_1-1/2IN_S_PA	10326943	21	1.5"	170.4	169.7	

Split sprockets with keyways are 'tight fit' onto the shaft and can be used for belt widths up to 680 mm and temperature differences of max. 30°C. For wider belts or bigger temperature differences, square bores have to be used.

Square sprockets can be used on the drive- and on the idler shaft. They 'float' freely on the shaft.

Split Sprockets and Idlers Moulded

Sprockets

NSH1005-13T_40MM_1KW_PA	10298197	13	40 mm	106,1	104,2	38
NSH1005-14T_40MM_1KW_PA	10298200	14	40 mm	114,1	112,5	
NSH1005-15T_40MM_1KW_PA	10298198	15	40 mm	122,1	120,7	
NSH1005-16T_40MM_1KW_PA	10349723	16	40 mm	130,2	128,9	
NSH1005-18T_40MM_1KW_PA	10298199	18	40 mm	146,3	145,3	
NSH1005-21T_40MM_1KW_PA	10292134	21	40 mm	170,4	169,7	

Idlers

NSH1005-13T_40MM_I_PA_GN	10678781	13	40 mm	106,1	104,2	38
NSH1005-14T_40MM_I_PA_GN	10678785	14	40 mm	114,1	112,5	
NSH1005-15T_40MM_I_PA_GN	10678782	15	40 mm	122,1	120,7	
NSH1005-16T_40MM_I_PA_GN	10678796	16	40 mm	130,2	128,9	
NSH1005-18T_40MM_I_PA_GN	10678783	18	40 mm	146,3	145,3	
NSH1005-21T_40MM_I_PA_GN	10678783	21	40 mm	170,4	169,7	

Il mantenimento di protocolli di igienizzazione elevata è importantissimo per le aziende di trasformazione di prodotti alimentari. Questa pratica importante è in grado di pulire e mantenere i nastri trasportatori in qualsiasi area dove i patogeni possono vivere e crescere. Considerando quanto sopra, è stato creato il nastro 1010 Serie KleanTop™, che offre un nastro fra i più facili da pulire.

Una pulizia duratura ed efficace

Le caratteristiche principali della Serie 1010 KleanTop vogliono garantire che le vostre operazioni siano sicure per gli alimenti. Col passare del tempo, i bordi dei nastri in plastica si consumano e sono un rischio per la produzione alimentare. La Serie 1010 KleanTop è progettata per eliminare il rischio di contaminazione del prodotto, rafforzando i bordi del nastro dove si può verificare una rottura.

Le zone delle cerniere sono difficili da vedere e da pulire. Questo è problematico in alcune applicazioni alimentari che richiedono che tutte le aree dell'operazione di trasporto siano le più igienizzate possibili. La Serie Rexnord 1010 presenta un design a cerniere completamente aperte, mettendo a nudo il 60 per cento del perno, e consentendo alla cerniera di essere pulita completamente in meno tempo, usando meno acqua e prodotti chimici.



Sistema trasportatore dotato di Catena KleanTop Rexnord Serie 1015.

Semplice assemblaggio e manutenzione

Alcuni nastri hanno dei design di ritenzione del perno complicati, aumentando il rischio di danneggiare il perno e/o il nastro. La Serie 1010 ha un sistema di ritenzione del perno semplificato, in grado di garantire operazione di montaggio e smontaggio con un semplice cacciavite, mantenendo al minimo i fermi macchina.

Prestazioni superiori nel settore

La combinazione di caratteristiche e vantaggi consente delle prestazioni di qualità superiore nelle applicazioni di prodotti da forno, snack, frutta e verdura, prodotti ittici e pollame.

Informazioni sul prodotto

- Nastro modulare in plastica disponibile con una larghezza minima di due pollici (50,8 mm) con incrementi di un pollice (25,4 mm).
- Sono disponibili quattro tipi di superfici: Nub Top, Flat Top, Perforated Flat Top e Perforated Nub Top (entrambi con il 20 per cento di area aperta).
- Pignoni lavorati disponibili in versione da 10, 12, 16, 18 e 20 denti.
- Disponibile nei materiali bianco e blu omologati FDA per contrasto visivo e identificazione.
- Facchini alti quattro pollici (101,6 mm) con nervature antiaederenti su entrambi i lati per ridurre l'adesione del prodotto su applicazioni inclinate e declinate.
- Sono disponibili sponde laterali alte due pollici (50,8 mm) e tre pollici (76,2 mm).



Sistema trasportatore dotato di Catena KleanTop Rexnord Serie 1011

Flat Top 1015

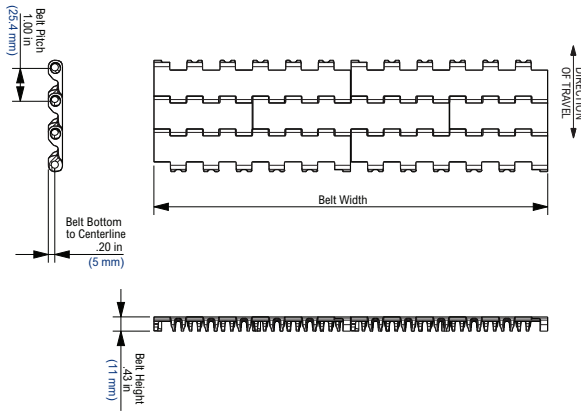
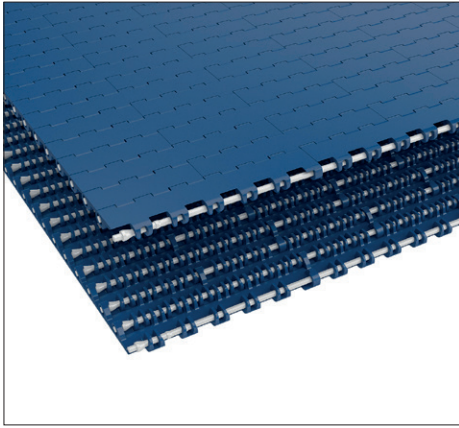

Rexnord 1015 Series KleanTop Belt Overview

Chain Type	Material	Standard Pin Material	Working Load (max)		Backflex Radius (min)	Temperature Range °C	
			lbs/ft / N/m	lbs/ft / kg/m		Dry	Wet
1015 FlatTop	WHT-BHT (Blue-White)	PBT	400 / 6.000	0.90 / 4.39	1.57 / 40	4 / 104	4 / 100
1015 FlatTop	WLT-BLT (Blue-White)	PBT	350 / 5.000	0.98 / 4.78		-73 / 27	-73 / 27
1015 FlatTop	WSM (White)	PBT	800 / 12.000	1.44 / 7.03		-40 / 82	-40 / 66

Perforated FlatTop 1016

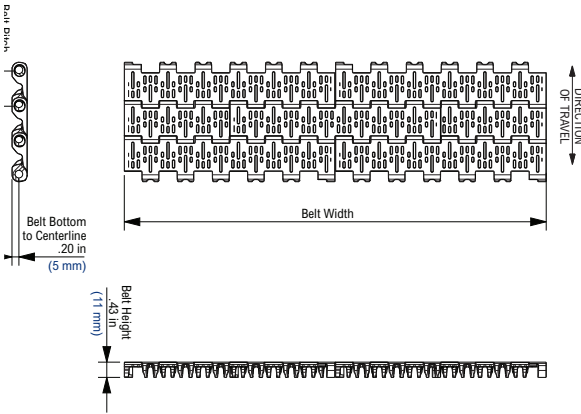
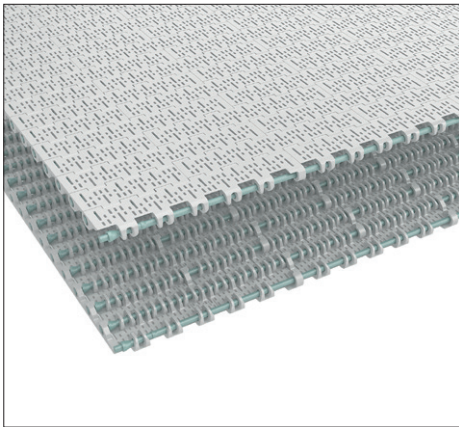

Rexnord 1016 Series KleanTop Belt Overview

Chain Type	Material	Standard Pin Material	Working Load (max)		Backflex Radius (min)	Temperature Range °C	
			lbs/ft / N/m	lbs/ft / kg/m		Dry	Wet
1016 Perforated FlatTop	WHT-BHT (Blue-White)	PBT	400 / 6.000	0.90 / 4.39	1.57 / 40	4 / 104	4 / 100
1016 Perforated FlatTop	WLT-BLT (Blue-White)	PBT	350 / 5.000	0.98 / 4.78		-73 / 27	-73 / 27
1016 Perforated FlatTop	WSM (White)	PBT	800 / 12.000	1.44 / 7.03		-40 / 82	-40 / 66

Nub Top 1011

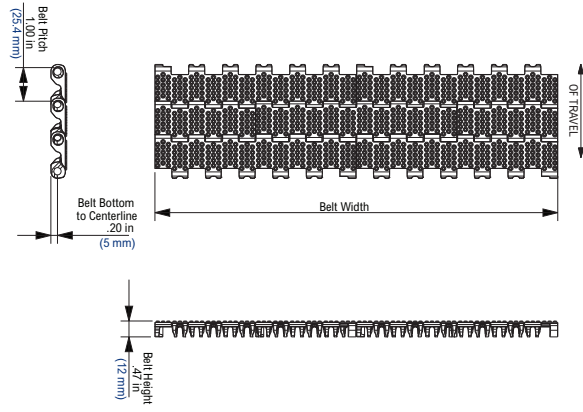
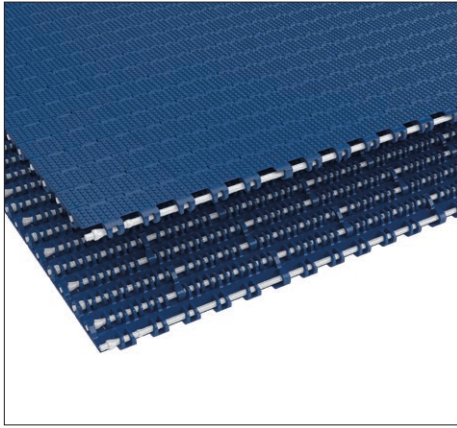

Rexnord 1011 Series KleanTop Belt Overview

Chain Type	Material	Standard Pin Material	Working Load (max)		Backflex Radius (min)	Temperature Range °C	
			lbs/ft / N/m	lbs/ft / kg/m		Dry	Wet
1011 Nub Top	WHT-BHT (Blue-White)	PBT	400 / 6.000	0.90 / 4.39	1.57 / 40	4 / 104	4 / 100
1011 Nub Top	WLT-BLT (Blue-White)	PBT	350 / 5.000	0.98 / 4.78		-73 / 27	-73 / 27
1011 Nub Top	WSM (White)	PBT	800 / 12.000	1.44 / 7.03		-40 / 82	-40 / 66

Perforated Nub Top 1018

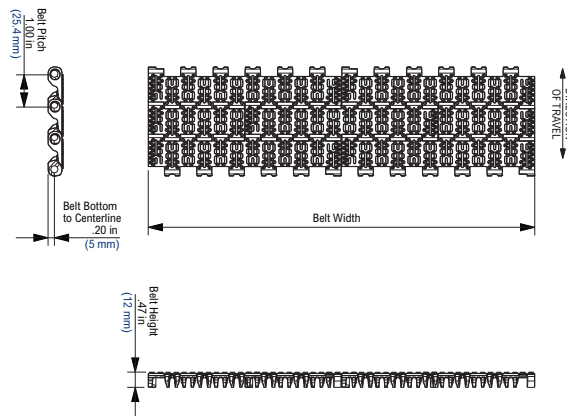
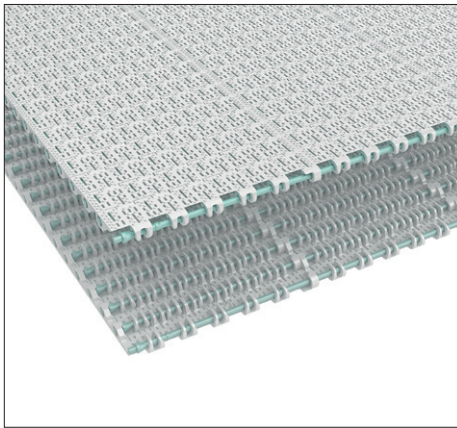

Rexnord 1018 Series KleanTop Belt Overview

Chain Type	Material	Standard Pin Material	Working Load (max)		Backflex Radius (min)	Temperature Range °C	
			lbs/ft / N/m	lbs/ft / kg/m		Dry	Wet
1018 Perforated Nub Top	WHT-BHT (Blue-White)	PBT	400 / 6.000	0.90 / 4.39	1.57 / 40	4 / 104	4 / 100
1018 Perforated Nub Top	WLT-BLT (Blue-White)	PBT	350 / 5.000	0.98 / 4.78		-73 / 27	-73 / 27
1018 Perforated Nub Top	WSM (White)	PBT	800 / 12.000	1.44 / 7.03		-40 / 82	-40 / 66

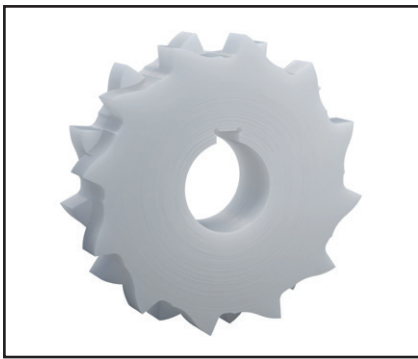

**Rexnord 1010 Series
KleanTop Belt
Bi-directional Drive
Sprocket KU1010**

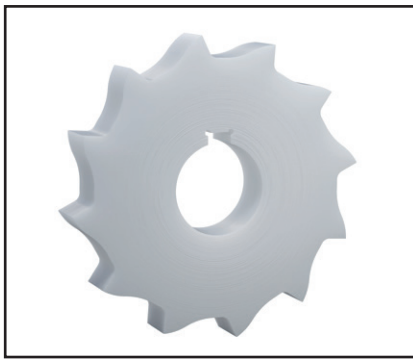

**Rexnord 1010 Series
KleanTop Belt
Uni-directional
Sprocket KU1010**

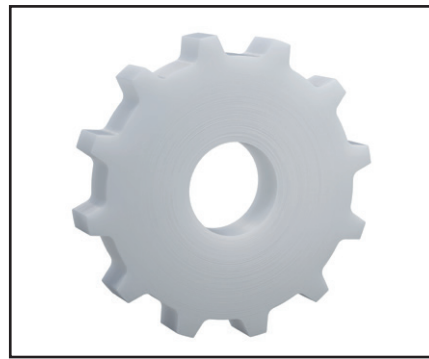

**Rexnord 1010 Series
KleanTop Belt
Idler
Sprocket KU1010**

Sprocket Type	Code Number	Number of Teeth	Shaft Size B	Width C	Pitch Diameter D	Outside Diameter E
			in / mm	in / mm	in / mm	in / mm
Rexnord 1010 Series Bi-directional Drive						
KU1010-10T_40MM_S_UH	10362465	10	1.57 / 40	0.98 / 25	3.24 / 82.19	3.26 / 82.7
KU1010-12T_40MM_S_UH	10332056	12	1.57 / 40	0.98 / 25	3.86 / 98.09	3.89 / 98.9
Rexnord 1010 Series Uni-directional Drive						
KU1010STR-10T_40MM_S_UH	10674758	10	1.57 / 40	0.59 / 15	3.24 / 82.19	3.26 / 82.7
KU1010STR-12T_40MM_S_UH	10674760	12	1.57 / 40	0.59 / 15	3.86 / 98.09	3.89 / 98.9
Rexnord 1010 Series Idler						
KU1010STR-10T_30MM_I_UH	10685630	10	1.18 / 30	0.59 / 15	3.24 / 82.19	3.26 / 82.7
KU1010STR-12T_30MM_I_UH	10685632	12	1.18 / 30	0.59 / 15	3.86 / 98.09	3.89 / 98.9

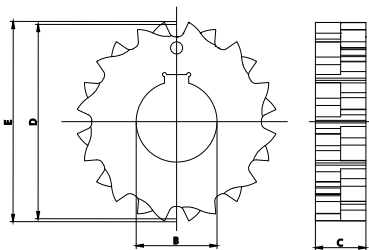

**Rexnord 1010 Series KleanTop Belt
Bi-directional Drive
Sprocket KU1010**

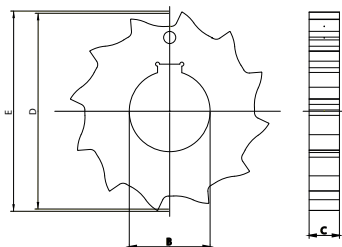

**Rexnord 1010 Series KleanTop Belt
Uni-directional
Sprocket KU1010**

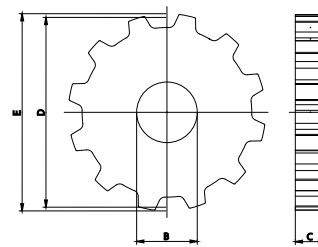

**Rexnord 1010 Series KleanTop Belt
Idler
Sprocket KU1010**

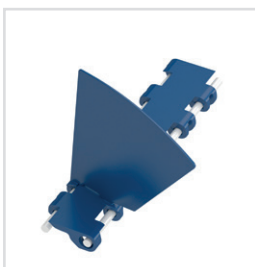

**Rexnord 1010 Series
KleanTop Belt Sideguard**



**Rexnord 1010 Series
KleanTop Belt Ribbed Flight
six inches (152.4 mm)
width, four inches
(101.6 mm) height,
one-inch (25.4 mm)
side indent**



**Rexnord 1010 Series
KleanTop Belt Ribbed Flight
six inches (152.4 mm),
four inches (101.6 mm)
height**

La Catena Rexnord 1020 Serie MatTop® offre una soluzione modulare completa con passo da un pollice (25,4 millimetri) per nastri trasportatori da pavimento per il settore automotive. La Catene 1020 Serie MatTop è sviluppata per l'uso in applicazioni per veicoli e automotive per il trasporto di persone.

Personalizzato per la vostra applicazione

La catena Serie 1020 MatTop viene proposta in una superficie SolidTop liscia oltre che in una superficie anti-scivolo SafetyTop per garantire delle superfici di lavoro ottimali per applicazioni specifiche. In funzione dell'applicazione, si può scegliere fra perni in plastica a prestazioni elevate o in acciaio inox. I perni in acciaio inox hanno una maggiore resistenza all'usura. Vengono utilizzati in situazioni dove si può prevedere della sporcizia e detriti.

Funzionamento affidabile

La serie di catene MatTop 1020 Rexnord abbina un funzionamento affidabile e scorrevole a tutti i vantaggi della catena MatTop:

- Resistente ai liquidi presenti nell'industria automobilistica
La ruota di traino a trasmissione positiva elimina lo slittamento, evitando che il pattino si attorcigli durante il trasporto
Riduzione dei consumi elettrici grazie al design della catena interamente in plastica, che riduce il peso globale sulla catena, garantendo un basso coefficiente di attrito
Elevata rigidità grazie al design della cerniera con interno stretto e il perno di grande diametro
Facile installazione e manutenzione
I danni sulla catena possono essere riparati sostituendo una singola maglia alla volta
- Dotata di serie di perni in PBT resistenti all'usura
- Il profilo diamantato piatto fornisce una caratteristica di anti-slittamento superiore



Sistema trasportatore dotato di Catena Rexnord 1020 Serie MatTop

Informazioni sul prodotto

- I moduli con passo da un pollice (25,4 millimetri) riducono al minimo l'azione cordale attorno ai pignoni di trasmissione e di traino.
- I pignoni sono disponibili di serie con 18 e 21 denti. Per il materiale FR-ESD, i pignoni verranno forniti con un passo esteso



Sistema trasportatore dotato di Catena Rexnord 1020 Serie MatTop

Solid Top 1025

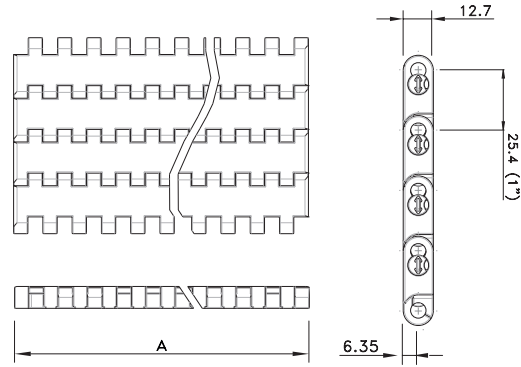
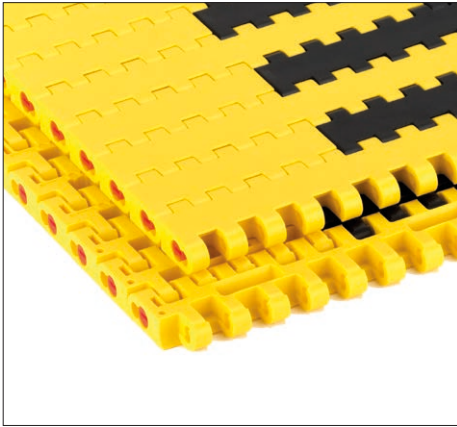

Assembly	Belt Type	Code Number*	Temperature range °C		Working Load (max.) N/m (21°C)	Weight kg/m ²	Backflex Radius (min.) mm
			Dry	Wet			
BM-Acetal with PBT Pins							
Standard	BM1025	I1025BMKXX	-40 to +80	up to 65	41000	13.50	25
HCAS-Acetal with PBT Pins							
Standard	HCAS1025	I1025HCASKXX	-18 to +80	-18 to +66	28000	13.50	25
FR-ESD-Polyamide with PBT Pins							
Standard	FR-ESD1025	I1025FRESKXX	-18 to +80	Not recommend	22000	13.50	25

* In code numbers xx corresponds with the belt width (A), starting with 10 for 85 mm, 11 for 170 mm and so on in steps of 85 mm up to 6120 mm. Other sizes upon request.

Safety Top 1029

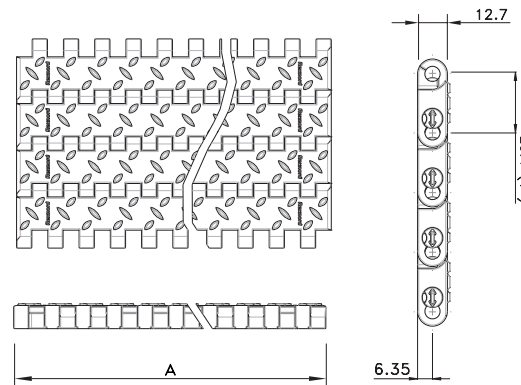

Assembly	Belt Type	Code Number*	Temperature range °C		Working Load (max.) N/m (21°C)	Weight kg/m ²	Backflex Radius (min.) mm
			Dry	Wet			
BM-Acetal with PBT Pins							
Standard	BM1029	I1029BMKXX	-40 to +80	up to 65	41000	13.50	25
HCAS-Acetal with PBT Pins							
Standard	HCAS1029	I1029HCASKXX	-18 to +80	-18 to +82	28000	13.50	25
FR-ESD-Polyamide with PBT Pins							
Standard	FR-ESD1029	I1029FRESKXX	-18 to +80	Not recommend	22000	13.50	25

* In code numbers xx corresponds with the belt width (A), starting with 10 for 85 mm, 11 for 170 mm and so on in steps of 85 mm up to 6120 mm. Other sizes upon request.

Split Sprockets and Idlers Machined

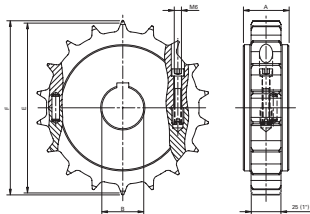
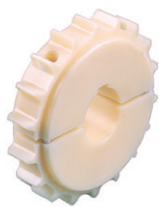

Split Sprockets and Idlers Moulded

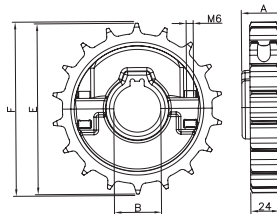

Sprocket Type	Code Number	Number of Teeth	Bore	Pitch Diameter	OutKUSde Diameter	Hub Width
			B mm/inch	E mm	F mm	A mm

Split Sprockets and Idlers Machined

Sprockets with Round Bores

KUS1005-18T_30MM_1KW_PA	10148133	18	30 mm	146.3	145.3	38
KUS1005-18T_40MM_1KW_PA	10148132	18	40 mm			
KUS1005-21T_30MM_1KW_PA	10331515	21	30 mm	170.4	169.7	
KUS1005-21T_40MM_1KW_PA	10332229	21	40 mm			
KUS1005-18T_1IN_1KW_PA	10326649	18	1.0"	146.3	145.3	
KUS1005-18T_1-1/2IN_1KW_PA	10148136	18	1.5"			
KUS1005-21T_1IN_1KW_PA	10326647	21	1.0"	170.4	169.7	
KUS1005-21T_1-1/2IN_1KW_PA	10326987	21	1.5"			

Idlers

KUS1005-18T_30MM_I_PA	10148135	18	30 mm	146.3	145.3	38
KUS1005-18T_40MM_I_PA	10148134	18	40 mm			
KUS1005-21T_30MM_I_PA	10331517	21	30 mm	170.4	169.7	
KUS1005-21T_40MM_I_PA	10332231	21	40 mm			
KUS1005-18T_1IN_I_PA	10326650	18	1.0"	146.3	145.3	
KUS1005-18T_1-1/2IN_I_PA	10148138	18	1.5"			
KUS1005-21T_1IN_I_PA	10326648	21	1.0"	170.4	169.7	
KUS1005-21T_1-1/2IN_I_PA	10326988	21	1.5"			

Sprockets with Square Bores

KUS1005-18T_40MM_S_PA	10148130	18	40 mm	146.3	145.3	38
KUS1005-21T_40MM_S_PA	10332228	21	40 mm	170.4	169.7	
KUS1005-18T_1-1/2IN_S_PA	10148131	18	1.5"	146.3	145.3	
KUS1005-21T_1-1/2IN_S_PA	10326943	21	1.5"	170.4	169.7	

Split sprockets with keyways are 'tight fit' onto the shaft and can be used for belt widths up to 680 mm and temperature differences of max. 30°C. For wider belts or bigger temperature differences, square bores have to be used.

Square sprockets can be used on the drive- and on the idler shaft. They 'float' freely on the shaft.

Split Sprockets and Idlers Moulded

Sprockets

NSH1005-13T_40MM_1KW_PA	10298197	13	40 mm	106,1	104,2	38
NSH1005-14T_40MM_1KW_PA	10298200	14	40 mm	114,1	112,5	
NSH1005-15T_40MM_1KW_PA	10298198	15	40 mm	122,1	120,7	
NSH1005-16T_40MM_1KW_PA	10349723	16	40 mm	130,2	128,9	
NSH1005-18T_40MM_1KW_PA	10298199	18	40 mm	146,3	145,3	
NSH1005-21T_40MM_1KW_PA	10292134	21	40 mm	170,4	169,7	

Idlers

NSH1005-13T_40MM_I_PA_GN	10678781	13	40 mm	106,1	104,2	38
NSH1005-14T_40MM_I_PA_GN	10678785	14	40 mm	114,1	112,5	
NSH1005-15T_40MM_I_PA_GN	10678782	15	40 mm	122,1	120,7	
NSH1005-16T_40MM_I_PA_GN	10678796	16	40 mm	130,2	128,9	
NSH1005-18T_40MM_I_PA_GN	10678783	18	40 mm	146,3	145,3	
NSH1005-21T_40MM_I_PA_GN	10678783	21	40 mm	170,4	169,7	

Le aziende di trasformazione di prodotti alimentari richiedono dei sistemi di trasporto personalizzati in grado di soddisfare i particolari requisiti del settore e le applicazioni individuali. Troppo spesso, i produttori di nastri trasportatori sviluppano prodotti utilizzati dai settori più svariati, obbligando le aziende di trasformazione di prodotti alimentari ad accettare dei piccoli compromessi che potrebbero influenzare le operazioni e la qualità dei prodotti. Considerando queste sfide, Rexnord ha creato il nastro KleanTop™ Serie 1090. A differenza dei nastri simili presenti sul mercato, la Serie 1090 è stata progettata per l'industria alimentare, offrendo la combinazione ottimale di resistenza e facilità di pulizia.

Conservare la qualità dei prodotti

Le caratteristiche principali della Serie 1090 fanno sì che i prodotti vengano lavorati in modo costante e sicuro. Il fondo dentato del nastro gli consente di scorrere su un rullo anziché su un pignone. Questa caratteristica è ottimale per quelle applicazioni che richiedono un raffreddamento efficiente, promuovendo un'ottima circolazione dell'aria ed evitando che vi siano delle zone morte, solitamente presenti attorno alle guide di scorrimento. Con un rullo si riducono anche i costi di magazzino e di manutenzione dei pignoni.

Pulizia efficace

Le zone delle cerniere spesso sono difficili da vedere e da pulire. La Serie 1090 presenta un design a cerniere aperte, garantendo così una buona facilità di accesso al perno e consentendo così di effettuare degli interventi igienici regolari che manterranno sempre pulita la zona attorno alla cerniera. La cerniera aperta offre anche il vantaggio di resistenza all'abrasione, il che consente all'asta di durare il più lungo possibile.

Prestazioni superiori nel settore

Data la combinazione di caratteristiche e vantaggi, la Serie 1090 garantisce delle prestazioni superiori per le applicazioni di trasporto di alimenti per le seguenti attività di trasformazione di prodotti alimentari:

- Prodotti da forno
- Snack Food
- Frutta e verdura
- Prodotti ittici



Sistema trasportatore dotato di Catena KleanTop Rexnord Serie 1096.

Informazioni sul prodotto

- Nastro modulare in plastica disponibile con una larghezza minima di quattro pollici, con incrementi di mezzo pollice.
- Versione con griglia a filo disponibile con il 45 per cento di area aperta.
- Pignoni lavorati disponibili in versione da 12, 18 e 20 denti, sia nei modelli a pezzo unico (KU) che diviso (KUS).
- Disponibile nei materiali bianco e blu omologati FDA per contrasto visivo e identificazione.
- Facchini da uno e due pollici di altezza con nervature antiaderenti.
- Sponde da uno e due pollici di altezza.

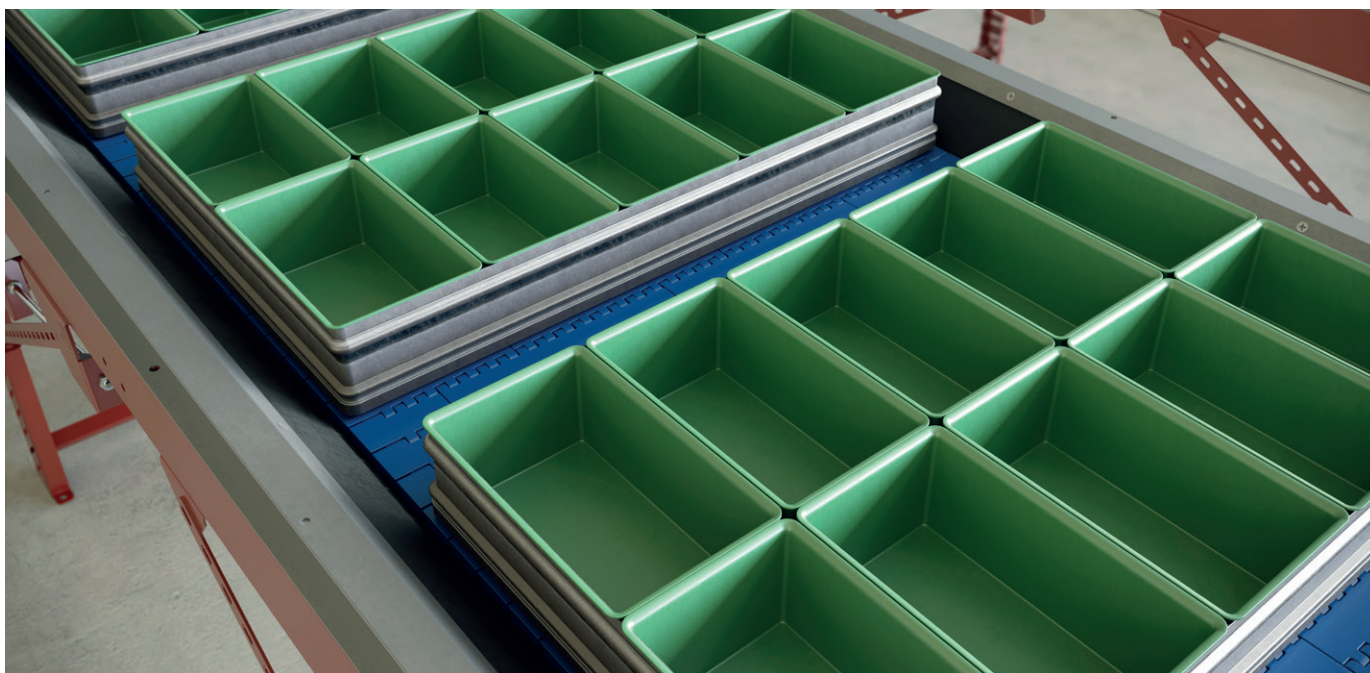

Sistema trasportatore dotato di Catena KleanTop Rexnord Serie 1095.

Flat Top 1095

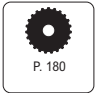
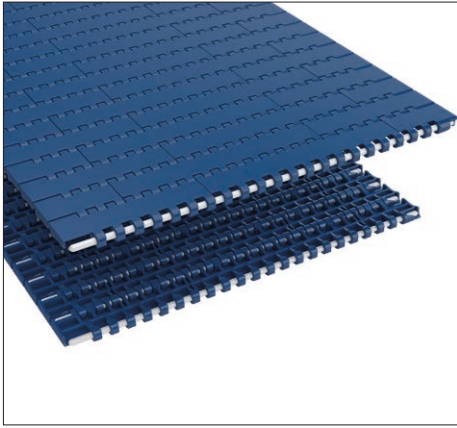

Rexnord 1095 Series KleanTop Belt Overview

Chain Type	Material	Standard Pin Material	Working Load (max)	Weight	Backflex Radius (min)	Temperature Range °C	
			N/m / lbs/ft	lbs/ft / kg/m		mm / in	Dry
FlatTop 1095	SMB (Blue)	PBT	1.500 / 21.884	1.48 / 7.23	0.680 / 17.2	-40 / 82	-40 / 66
FlatTop 1095	WHT (White)	PBT	900 / 13.130	0.95 / 4.64		4 / 104	4 / 100
FlatTop 1095	BHT (Blue)	PBT	900 / 13.130	0.95 / 4.64		4 / 104	4 / 100

General information:

- Plastic modular belt available in minimum width of four inches and increments of a half-inch

Flat Top 1096

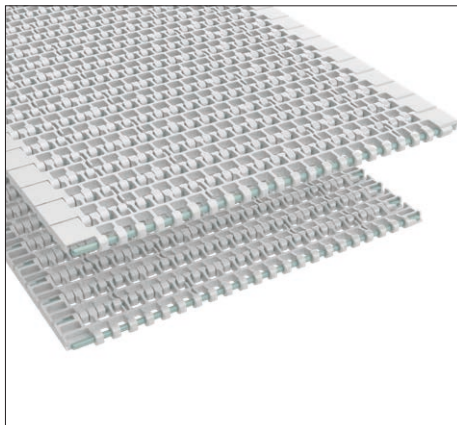

Rexnord 1096 Series KleanTop Belt Material Overview

Chain Type	Material	Standard Pin Material	Working Load (max)	Weight	Backflex Radius (min)	Temperature Range °C	
			N/m / lbs/ft	lbs/ft / kg/m		mm / in	Dry
Flush Grid 1096	SMB (Blue)	PBT	1.500 / 21.884	1.12 / 5.47	0.680 / 17.2	-40 / 82	-40 / 66
Flush Grid 1096	WHT (White)	PBT	900 / 13.130	0.72 / 3.52		4 / 104	4 / 100
Flush Grid 1096	BHT (Blue)	PBT	900 / 13.130	0.72 / 3.52		4 / 104	4 / 100

KU1090 Thermoplastic Sprocket

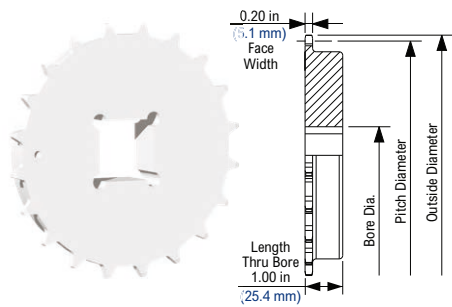

KUS1090 Thermoplastic Split Sprocket

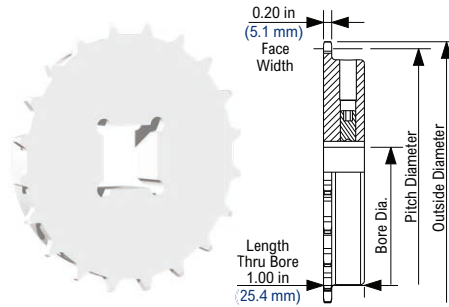

KU1090 Thermoplastic Sprocket Information

Number of Teeth		Pitch Diameter		Outside Diameter		Bore Diameter (Shaft-Ready)								Bore Diameter (Idler)				Approximate Weight	
						Round				Square				in		mm			
						in		mm		in		mm		in		mm			
actual	effect	min	max	min	max	min	max	min	max	min	max	min	max	min	max	min	max	lbs	kg
12T	12T	3.9	98.2	3.9	98	1	1-3/4	25	45	1	1-19/32	25	40	1	2-1/2	25	65	0.26	0.12
18T	18T	5.8	146.3	5.8	147.3	1	3-19/64	25	80	1	3	25	75	1	4-1/2	25	115	0.77	0.35
20T	20T	6.4	162.4	6.5	163.9	1	3-1/2	25	85	1	3-19/64	25	80	1	5	25	127	0.95	0.43

KUS1090 Thermoplastic Split Sprocket Information

Number of Teeth		Pitch Diameter		Outside Diameter		Bore Diameter (Shaft-Ready)								Bore Diameter (Idler)				Approximate Weight	
						Round				Square				in		mm			
						in		mm		in		mm		in		mm			
actual	effect	min	max	min	max	min	max	min	max	min	max	min	max	min	max	min	max	lbs	kg
12T	12T	3.9	98.2	3.9	98	-	-	-	-	1	1.5	25	35	-	-	-	-	0.24	0.11
18T	18T	5.8	146.3	5.8	147.3	1	2-3/4	25	70	1	2.8	25	70	1	3-19/64	25	80	0.82	0.37
20T	20T	6.4	162.4	6.5	163.9	1	3	25	75	1	3.3	25	80	1	3-1/2	25	85	1.00	0.45

Il nastro serie 7700 con passo da 1 pollice per carichi pesanti è utilizzato per un'ampia gamma di applicazioni. Grazie alla loro struttura robusta, questi nastri sono utilizzati comunemente per l'industria del vetro e automobilistica. I nastri della serie 7700 sono disponibili nella versione chiusa, con due aperture, superficie gommata e LBP. Per il trasporto su singola via, sono disponibili varie versioni stampate in base alla larghezza con guide Tab. Per le applicazioni nell'industria del vetro e delle bevande, il sistema di trasferimento dinamico è la soluzione ideale. Di serie, i nastri vengono forniti in acetaleica e polipropilene ad elevate prestazioni

Caratteristiche

- La struttura a modulo robusto con spessore da ½ pollice è estremamente resistente.
- L'acetaleica HP riduce l'attrito, offre un'ottima resistenza all'usura e crea possibilità per l'utilizzo a secco.
- Bordi esterni arrotondati per un miglioramento dei trasferimenti laterali e migliore movimentazione dei prodotti.
- La ritenzione dei perni Twist-lock™ mediante un tappo incernierato evita la perdita del tappo e consente un agevole accesso ai perni per le operazioni di installazione e manutenzione.
- Il sistema di trasferimento dinamico (DTS) consente trasferimenti senza problemi di 90°.
- La struttura dei nastri e delle ruote di rinvio garantisce un innesto ottimale e un trasporto affidabile.
- I nastri serie 7700 sono abbinati ai nastri a catena FTM 1055, o FT 1050, in modo da creare un abbinamento perfetto tra corsa rettilinea e trasportatori curvilinei; i nastri 7700 possono essere trasportati anche da ruote di traino NS 7700.

Programma	
7705 Solid Top	Superficie chiusa; per applicazioni nel settore del vetro e dei materiali in PET per carichi pesanti, la versione metrica può essere munita anche di Positrack
7706 Perforated Top	Area aperta all'8%; per la movimentazione di lattine per bevande
7708 Perforated Top	Area aperta all'20%; per i riscaldatori e i refrigeratori
7705 Rubber Top	Per trasportatori inclinati e in discesa fino a 20°; disponibili su richiesta
Positrack	Guide per l'inserimento preciso del nastro nel trasportatore (solo versione metrica e DTS)
DTS®	Sistema di trasferimento dinamico a modulo singolo per i trasferimenti a spostamento automatico verso sinistra o verso destra per evitare piastre morte con trasferimenti a 90°; di serie, viene fornito il sistema di guida Positrack



Trasferimento di bottiglie con nastro 7705



Trasportatore con nastro TCF7705

Solid Top 7705

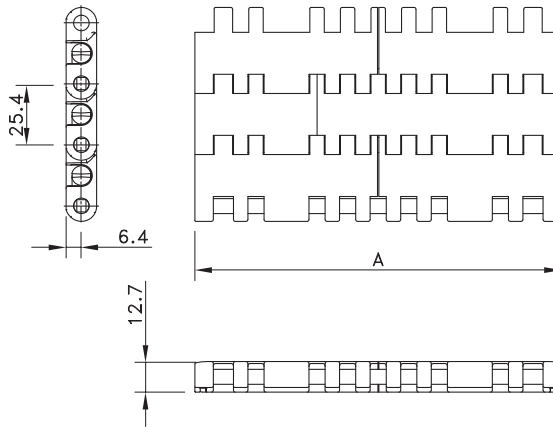
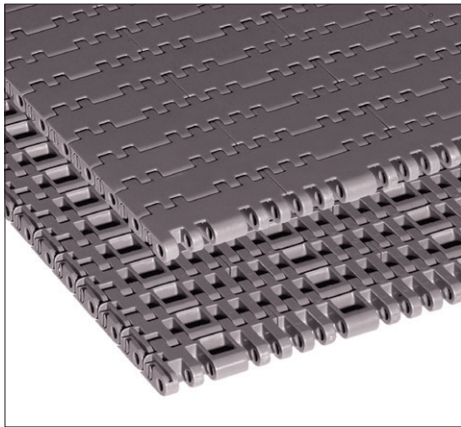

Assembly	Belt Type	Code Number*	Temperature range °C		Working Load (max.) N/m (21°C)	Weight kg/m ²	Backflex Radius (min.) mm
			Dry	Wet			

HP-Acetal with PBT Pins

Standard	HP 7705	I7705HPKxx	-40 to +80	-40 to +65	43000 N/m	13.47 kg/m ²	25
DTS Left Positrack	HP7705DTS-4.5IN_MTW_PT_LH	10028409					
	HP7705DTS-7.5IN_MTW_PT_LH	10374619					
DTS right Positrack	HP7705DTS-4.5IN_MTW_PT_RH	10028410					
	HP7705DTS-7.5IN_MTW_PT_RH	10028415					
Mould to width positrack	HP7705-3.25IN_MTW_PT	10028408			3047 N	1.03 kg/m	
	HP7705-4.5IN_MTW_PT	10028412			4559 N	1.39 kg/m	
	HP7705-7.5IN_MTW_PT	10285507			7784 N	2.58 kg/m	

BWX-Polyamide with Polyacetal Pins

Standard	BWX7705	BWX7705-xx	-40 to +80	Not recommended	43000 N/m	13.47 kg/m ²	25
Mould to width positrack	BWX7705-3.25IN_MTW_PT	10146200					
	BWX7705-4.5IN_MTW_PT	10146012					
	BWX7705-7.5IN MTW PT	10282299					

* In code numbers xx corresponds with the belt width (A). Standard widths of these belts begin at 6" with 3" increments up to 120". Special widths start from 5" with 1/2" increments. see also page 208. Upon request 7705 belts can be supplied in metric versions. 7705 belts are also available with rubber top in HTF and TCF versions. Please contact Customer Service for more details.

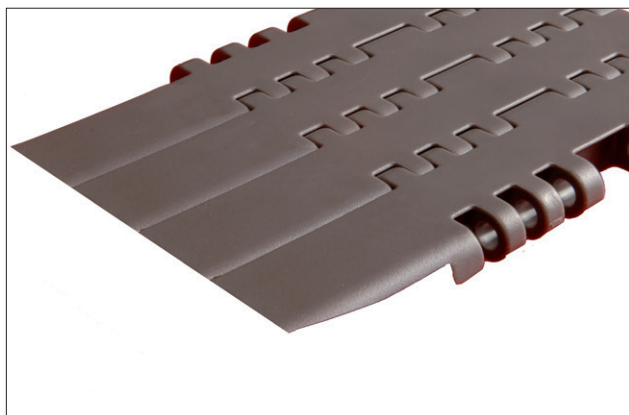

Dynamic Transfer System (DTS®)

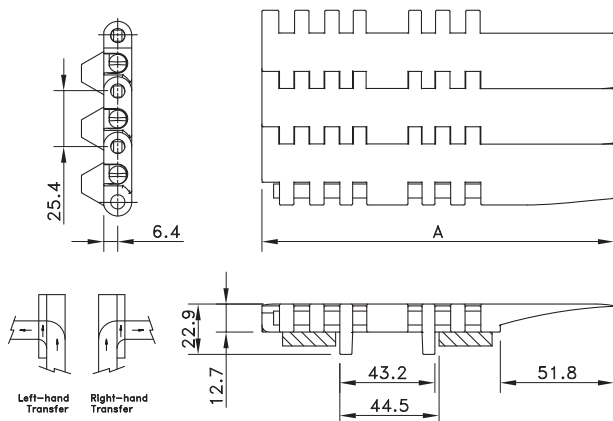

Rubber Top 7705

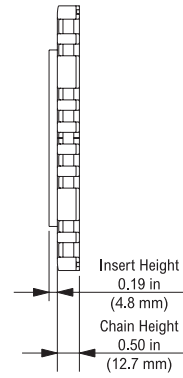
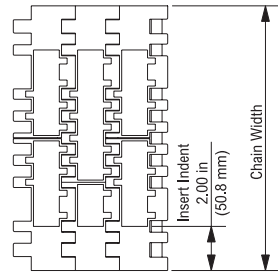
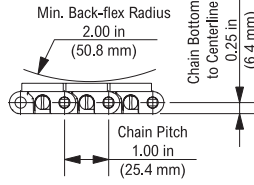
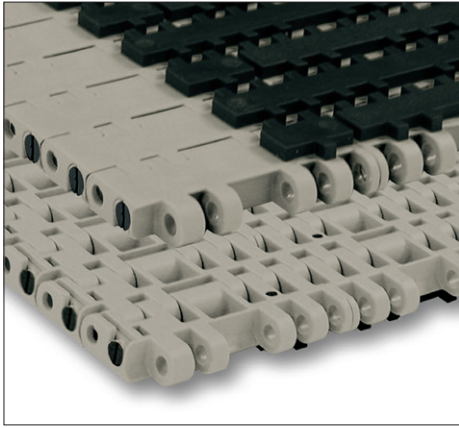

Assembly	Belt Type	Code Number*	Temperature range °C		Working Load (max.) N/m (21°C)	Weight kg/m ²	Backflex Radius (min.) mm
			Dry	Wet			
TCF-Tough Composite Friction Top							
Standard	TCF 7705	TCF7705-xx	-40 to +80	-40 to +65	32000 N/m	12.84 kg/m ²	25
HTF-High Temperature Friction Top							
Standard	HTF 7705	HTF7705-xx	+4 to +104	+4 to +104	26000 N/m	10.59 kg/m ²	25

HTX7748

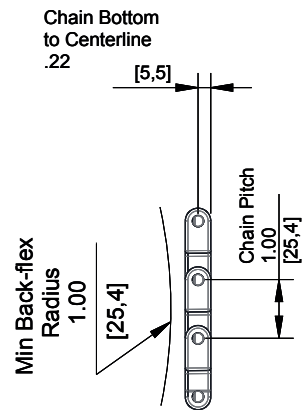
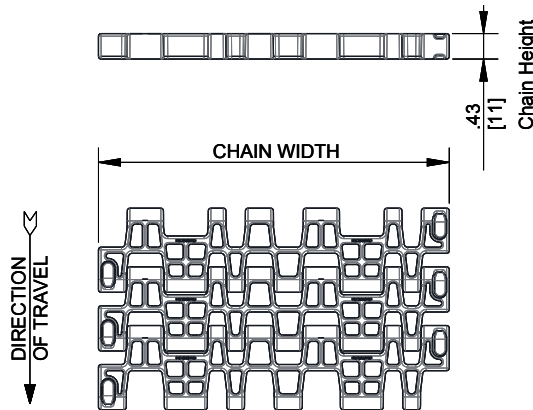

Assembly	Belt Type	Code Number*	Temperature range °C		Working Load (max.) N/m (21°C)	Weight kg/m ²	Backflex Radius (min.) mm
			Dry	Wet			
HTX-Advanced Performance Polymer Alloy with stainless steel pins							
Standard	HTX7748	I7748HTXKxx	Dry: max -40 to +135 min	Wet: max -40 to NR	29.180	10.36	25

* In code numbers xx corresponds with the belt width (A). Standard nominal widths of these belts begin at 225 mm with 75 mm increments up to 2475 mm. Other sizes upon request. See also page 208.

Perforated Top 7706

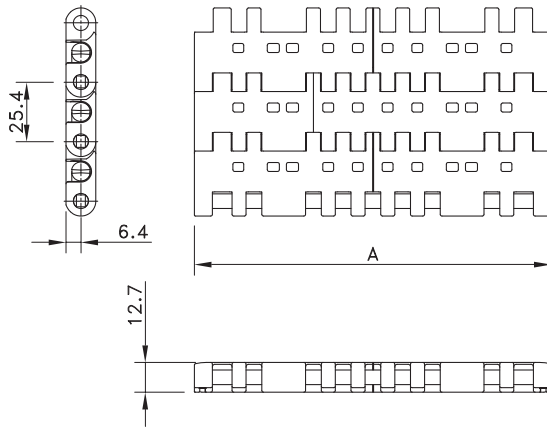
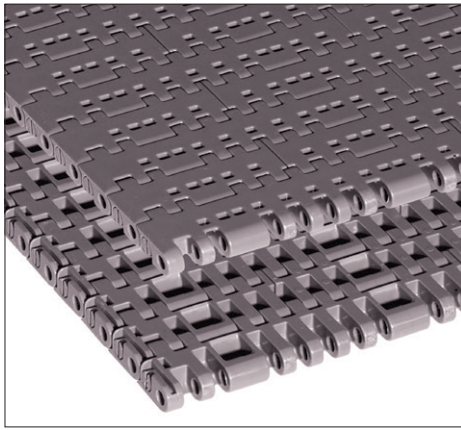

Assembly	Belt Type	Code Number*	Temperature range °C		Working Load (max.) N/m (21°C)	Weight kg/m ²	Backflex Radius (min.) mm
			Dry	Wet			
HP-Acetal with Polypropylene Pins							
Standard	HP 7706	I7706HPKxx	-40 to +80	-40 to +65	43000	13.18	25

* In code numbers xx corresponds with the belt width (A). Standard widths of these belts begin at 6" with 3" increments up to 120". Special widths start from 5" with 1/2" increments. See also page 208.

For DTS, modules from page 172 are used.

7706 belts can be supplied in metric versions upon request.

Perforated Top 7708

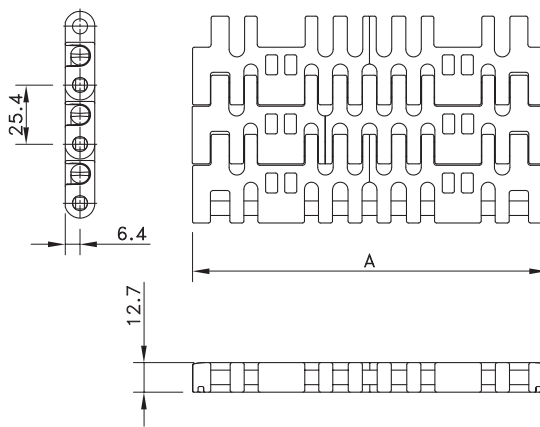
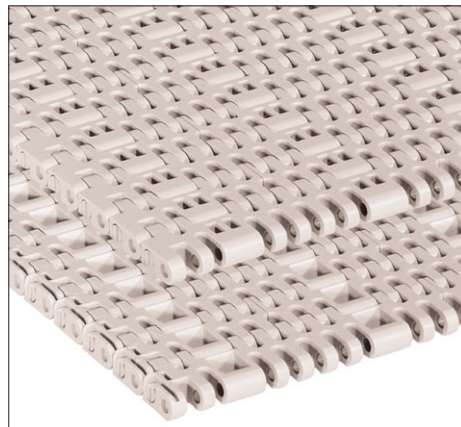

Assembly	Belt Type	Code Number*	Temperature range °C		Working Load (max.) N/m (21°C)	Weight kg/m ²	Backflex Radius (min.) mm
			Dry	Wet			
HT-Polypropylene with Polypropylene Pins							
Standard	HT 7708	I7708HTKxx	4 to 100	4 to 100	26000	7.81	25
USP-Polypropylene with Polypropylene Pins							
Standard	USP 7708	USP7708Kxx	4 to 100	4 to 100	26000	7.81	25

* In code numbers xx corresponds with the belt width (A). Standard widths of these belts begin at 9" with 3" increments up to 120". Special widths start from 5" with 1/2" increments. See also page 208.

Split Sprockets Injection Moulded

Split Sprockets Machined

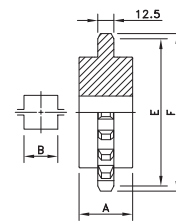
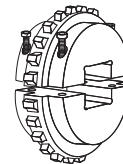
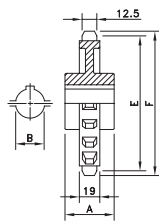

Sprocket Type	Code Number	Number of Teeth	Bore	Pitch Diameter	Outside Diameter	Hub Width
			B	E	F	A
Round Bores						
mm/inch						
NS7700-16T_25MM_1KW_PA	10028572	16	25	130.2	130.6	51
NS7700-16T_30MM_1KW_PA	10019897	16	30			
NS7700-16T_35MM_1KW_PA	10331967	16	35			
NS7700-16T_40MM_1KW_PA	10028573	16	40			
NS7700-18T_25MM_1KW_PA	10028579	18	25	146.3	146.9	
NS7700-18T_30MM_1KW_PA	10019875	18	30			
NS7700-18T_35MM_1KW_PA	10028581	18	35			
NS7700-18T_40MM_1KW_PA	10028583	18	40			
NS7700-21T_25MM_1KW_PA	10028594	21	25	170.4	170.7	
NS7700-21T_30MM_1KW_PA	10331629	21	30			
NS7700-21T_35MM_1KW_PA	10331966	21	35			
NS7700-21T_40MM_1KW_PA	10028595	21	40			
Square Bores						
KUS7700-16T_40MM_S_PA	10332278	16	40	130.2	130.6	51
KUS7700-18T_40MM_S_PA	10332294	18	40	146.3	146.9	
KUS7700-18T_50MM_S_PA	10332896	18	50			
KUS7700-21T_40MM_S_PA	10332282	21	40	170.3	170.7	
KUS7700-21T_50MM_S_PA	10332884	21	50			
KUS7700-21T_60MM_S_PA	10333321	21	60			

Classic Sprockets Machined

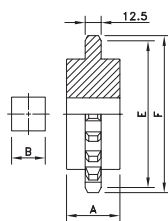

Sprocket Type	Code Number	Number of Teeth	Bore	Pitch Diameter	Outside Diameter	Hub Width
			B	E	F	A
mm/inch						
Square Bores						
KU7700-18T_50MM_S_PA	10332774	18	50	146.3	146.9	51
KU7700-18T_60MM_S_PA	10072754	18	60			
KU7700-21T_50MM_S_PA	10332777	21	50	170.3	170.7	
KU7700-21T_60MM_S_PA	10333240	21	60			
KU7700-21T_65MM_S_PA	10333456	21	65			
KU7700-25T_50MM_S_PA	10332778	25	50	202.7	204.2	

Round bores are available upon request.

Il nastro Serie 2000 con passo da 2 pollici è tipicamente utilizzato nelle applicazioni per carichi pesanti, come ad esempio i pastorizzatori, i pallettizzatori e i tavoli di accumulo. I moduli sono progettati con nervature trasversali rigide e le ruote di traino multiangolari supportano i moduli in modo ottimale. Di serie, i nastri vengono forniti in polipropilene resistente alle elevate temperature e ai prodotti chimici.

Caratteristiche

- Ritenzione dei perni mediante clips per una facile installazione e manutenzione.
- Struttura Raised Rib per creare un'elevata rigidità dei moduli e consentire la movimentazione di grandi carichi di prodotti e fornire una superficie piana per una movimentazione ottimale dei prodotti.
- Eccezionale facilità nella movimentazione dei prodotti dal o verso il nastro mediante il sistema di trasferimento DTS-C® utilizzato insieme al nastro raised rib 2000.

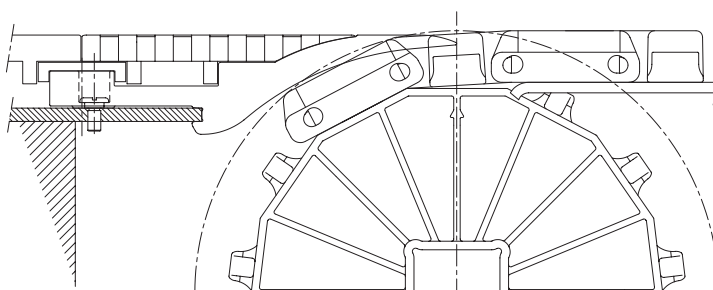
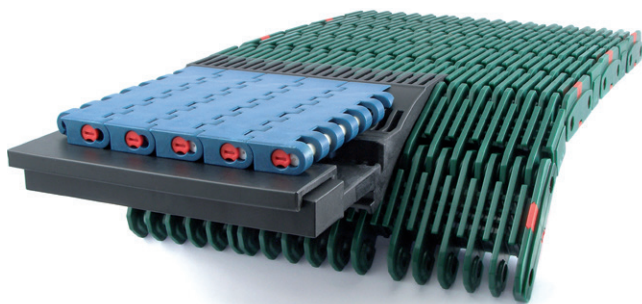

Questo sistema consiste in un pettine statico unito a un DTS® in movimento o a un nastro FreeFlow. Il nastro è posizionato sulla superficie del pettine di trasferimento DTS-C®, consentendo i trasferimenti a spostamento automatico; questo è importante se si passa da una serie di prodotti all'altra in una linea di riempimento/trattamento e se i prodotti "riempiti a caldo" non devono restare sul trasferimento di entrata del refrigeratore.

Il trasferimento DTS-C® non richiede spazzatrici e garantisce una maggiore efficienza delle linee. Il nastro DTS® nel sistema e la catena o il nastro nel trasportatore di entrata o uscita principale sono supportati dalla stessa guida di scorrimento centrale pettine di trasferimento, consentendo di risparmiare tempo per l'installazione ed evitando regolazioni dell'altezza del trasportatore.

Programma	
2000 Flat Top (FT)	Superficie chiusa per prodotti di grandi dimensioni e pesanti
2000 Flush Grid (FG)	Area aperta al 31%; garantisce un flusso ottimale di acqua e aria e consente il passaggio dello sporco; ideale per l'industria alimentare e automobilistica
2000 Raised Rib Heavy Duty (RRHD)	Area aperta al 27%; rinforzata per affrontare le condizioni difficili nei pastorizzatori di vetro (una direzione) e nelle applicazioni a doppio uso (lattine e bottiglie)
2000 Super Rib (SR)	Area aperta 27%; La nervatura centrale completamente rinforzata produce un design estremamente rigido. Progettata per ottimizzare le prestazioni dei pastorizzatori in condizioni estreme e ottimizzato l'utilizzo in combinazione con le applicazioni per lattine e vetro. La Serie Rexnord SR 2000 MatTop è appositamente progettata per trasporto PET.
Positrack	Guide nelle versioni Raised Rib per una movimentazione accurata e precisa del nastro nei tunnel del pastorizzatore, consentendo un utilizzo ottimale della superficie del nastro
Pettini di trasferimento	Sistema DTS® per i trasferimenti a automatici, Click-Comb standard per lattine e Click-Comb per l'industria del vetro; trasferimenti estremamente precisi



Riscaldatore di bottiglie di vetro con nastro a nervatura sollevata 2000 e trasferimento DTS-C®

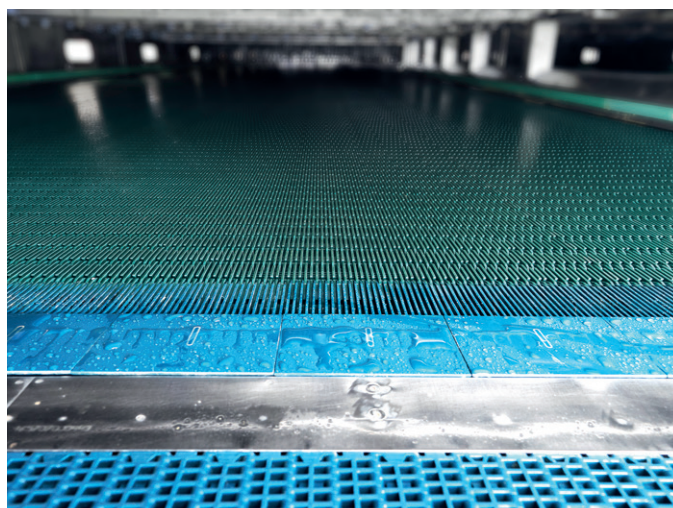

Accumulo Di Bottiglie Su Nastro 2000

Flat Top 2000

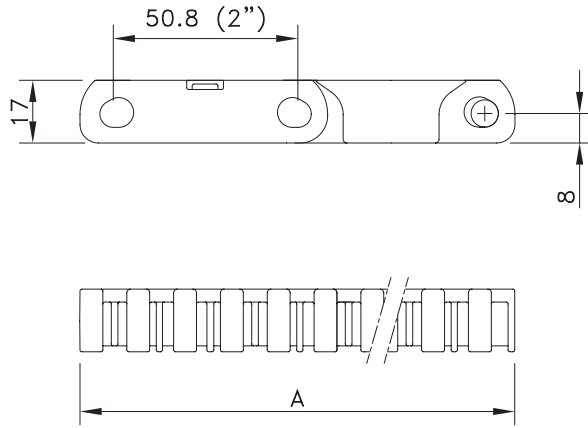
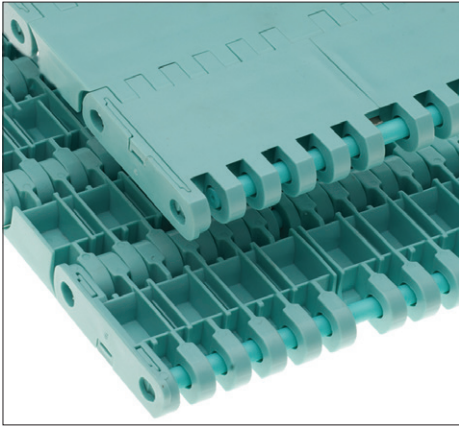

Assembly	Belt Type	Code Number*	Temperature range °C		Working Load (max.) N/m (21°C)	Weight kg/m ²	Backflex Radius (min.) mm
			Dry	Wet			
XP-Polypropylene with Polypropylene Pins							
Standard	XP 2000 FT	838.30.xx	4 to 104	4 to 104	29500	8.20	45

* In code numbers xx corresponds with the belt width (A), starting with 10 for 3", 11 for 6" and so on in steps of 3". See also page 223.

Flush Grid 2000

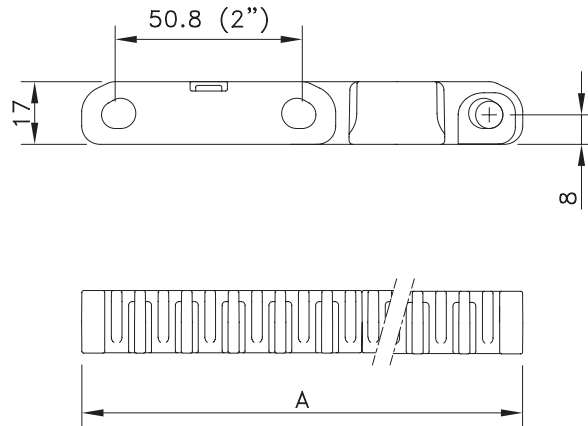
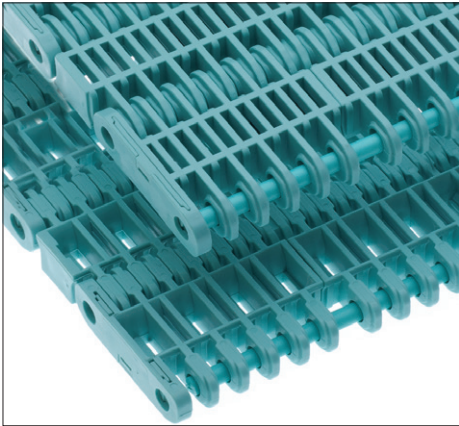

Assembly	Belt Type	Code Number*	Temperature range °C		Working Load (max.) N/m (21°C)	Weight kg/m ²	Backflex Radius (min.) mm
			Dry	Wet			
XP-Polypropylene with Polypropylene Pins							
Standard	XP2000FG	838.40.xx	4 to 104	4 to 104	29500	7.55	35

* In code numbers xx corresponds with the belt width (A), starting with 10 for 3", 11 for 6" and so on in steps of 3". See also page 223.

Raised Rib 2000 Heavy Duty

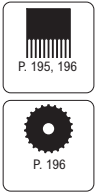
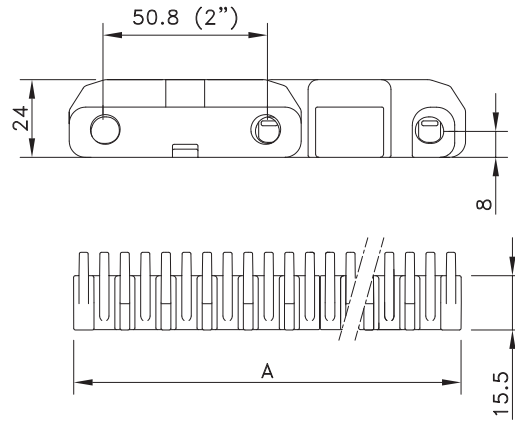
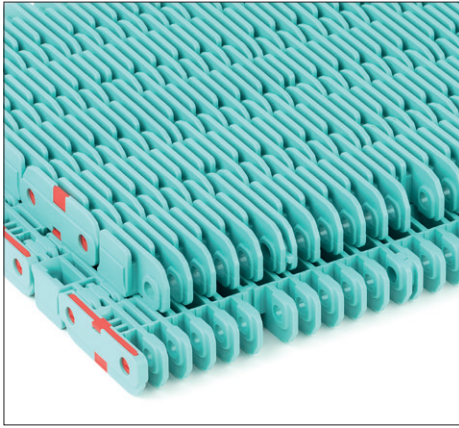

Assembly	Belt Type	Code Number*	Temperature range °C		Working Load (max.) N/m (21°C)	Weight kg/m ²	Backflex Radius (min.) mm
			Dry	Wet			
XP-Polypropylene with Polypropylene Pins							
Standard	RRHD 2000 XP	838.10.xx	4 to 104	4 to 104	29500	10.60	75
Positrack	RRHDP 2000 XP	838.90.xx					

* In code numbers xx corresponds with the belt width (A), starting with 10 for 3", 11 for 6" and so on in steps of 3". 2000 Belts with Positrack start with 12 for 9". See also page 223.

Chain assembly tool (chain tensioner) code 10361333.

Raised Rib 2000 Heavy Duty

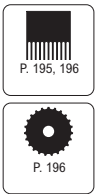
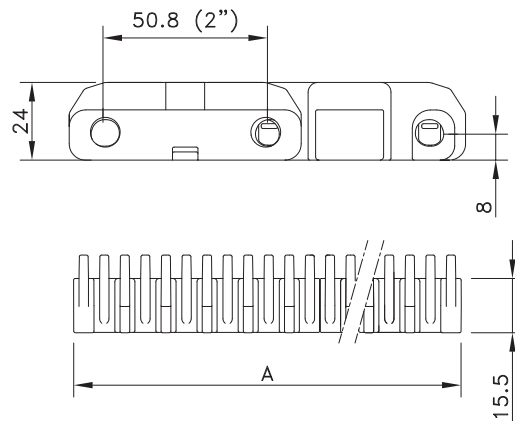
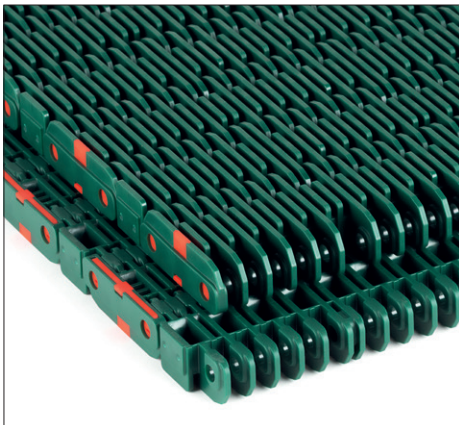

Assembly	Belt Type	Code Number*	Temperature range °C		Working Load (max.) N/m (21°C)	Weight kg/m ²	Backflex Radius (min.) mm
			Dry	Wet			
USP-Polypropylene with Polypropylene Pins							
Standard	RRHD 2000 USP	881.60.xx	4 to 104	4 to 104	29500	11.20	75
Positrack	RRHDP 2000 USP	881.90.xx					

* In code numbers xx corresponds with the belt width (A), starting with 10 for 3", 11 for 6" and so on in steps of 3". 2000 Belts with Positrack start with 12 for 9". See also page 223.

Chain assembly tool (chain tensioner) code 10361333.

Super Rib 2000

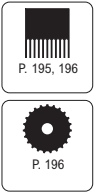
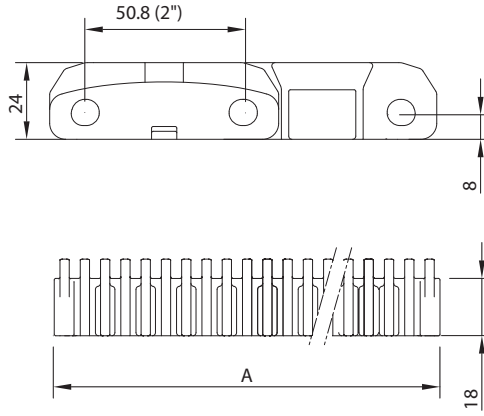
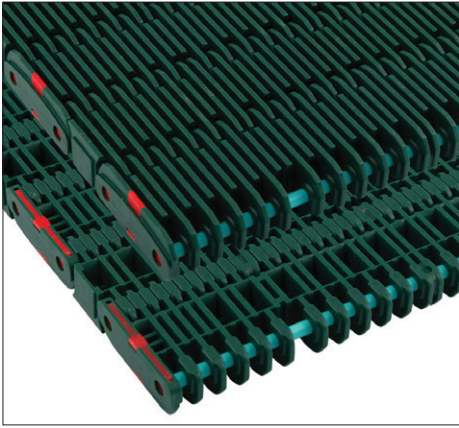

Assembly	Belt Type	Code Number*	Temperature range °C		Working Load (max.) N/m (21°C)	Weight kg/m ²	Backflex Radius (min.) mm
			Dry	Wet			
USP-Polypropylene with Polypropylene Pins							
Standard	SR 2000 USP	881.50.xx	4 to 104	4 to 104	29500	11.20	75
Positrack	SRP 2000 USP	881.80.xx					

* In code numbers xx corresponds with the belt width (A), starting with 10 for 3", 11 for 6" and so on in steps of 3". 2000 Belts with Positrack start with 12 for 9". See also page 208.

Chain assembly tool (chain tensioner) code 10361333.

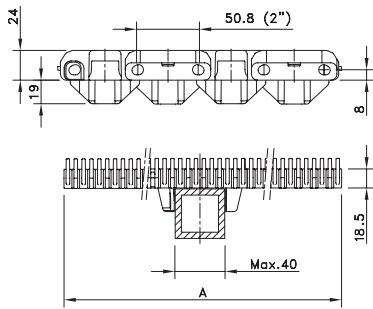

Super rib 2000 belt with positrack in the center of the belt or 1.5" Offset, depending on the width

Click-Comb Fingerplates Standard

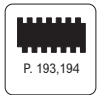
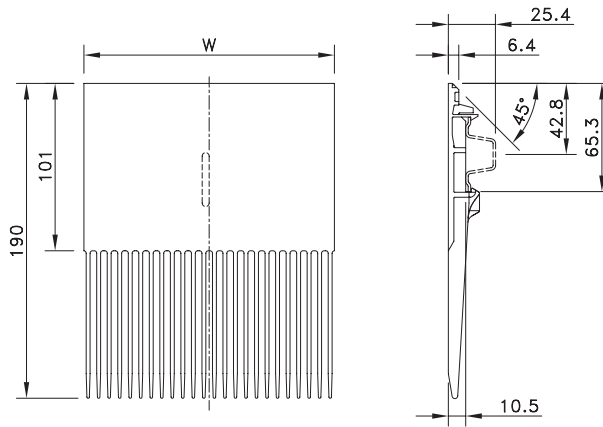
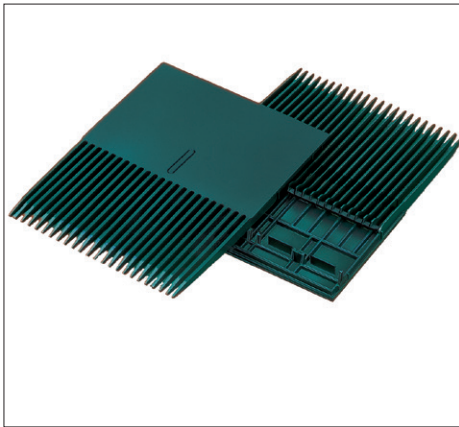

'Click-Comb' Fingerplate type	Code Number	Length	Width W	Weight ≈
		mm	mm	kg
XLG-Acetal				
TRAN PLT COMB XLG2000 190X152MM_OMEGA	10147612	190	151	0.16
TRAN PLT COMB XLG2000-190X74MM_HIGH	10362004	190	74	0.08

Click-Comb Fingerplates for Glass Handling

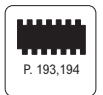
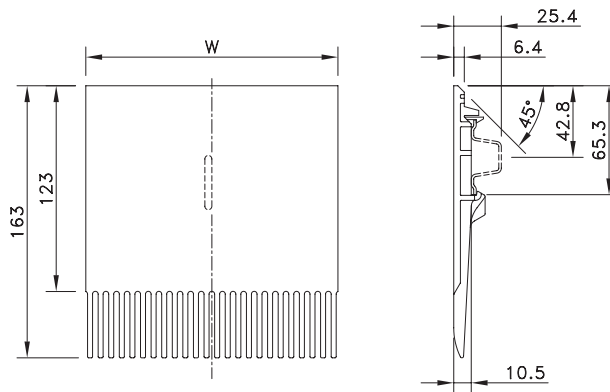
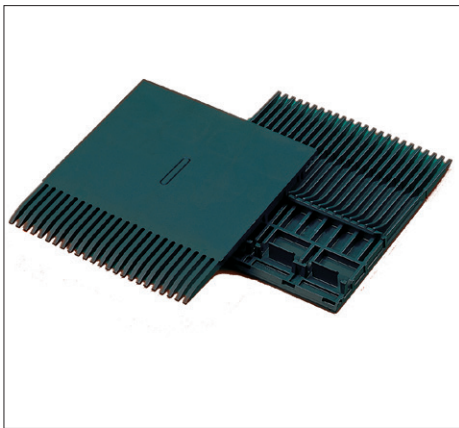

'Click-Comb' Fingerplate type	Code Number	Length	Width W	Weight ≈
		mm	mm	kg
XLG-Acetal				
TRAN PLT COMB XLG2000 163X152MM_GLASS	10147614	163.1	151	0.16
TRAN PLT COMB XLG2000-163X74MM_GLASS	10362005	163.1	74	0.08



Code Number	Length L	Type	Weight	Pitch X		Number of Pitches	Height H
	mm		kg	mm	inch		mm
Profiles for Fingerplates							
Stainless Steel							
10724982	3040	Prof. For comb H=15 mm L=3040 mm	2.44	76.2	3.00	39.9	15

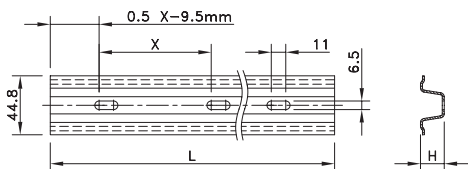

DTS-C® Transfer System for Pasteurizers

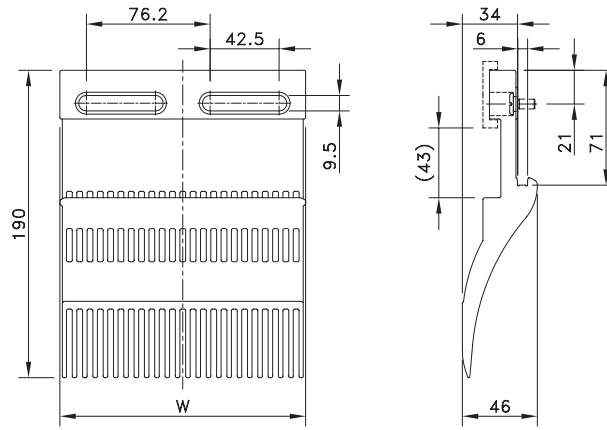
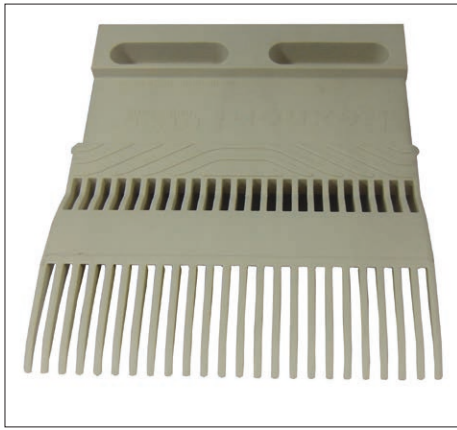

Product	Code Number	Length	Width W	Weight ≈
		mm	mm	kg
Reinforced Polyamide				
TRAN PLT DTS-C 2000-1005 190X152MM WH	10296369	190	152	0.25
*DTS-C is optimized for 16 tooth sprocket size				
Wearstrip DTS-C 2000				
CHN GUIDE 362 C-PROF W41XT4MM BK 3.05M	10350021	3		
CHN GUIDE 362 C-PROF W41XT4MM BK 6.05M	10324496	6		

Split Sprockets

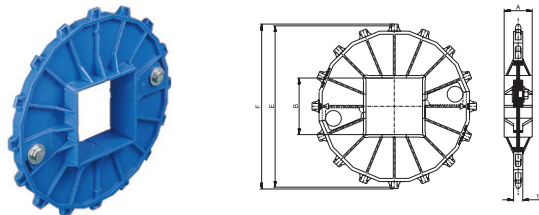

Classic Sprockets

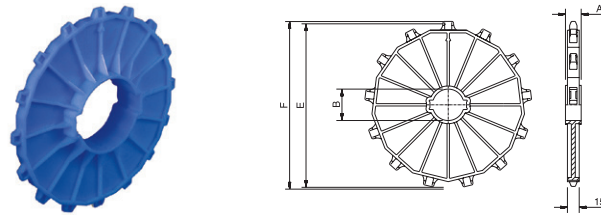

Sprocket Type	Code Number	Number of Teeth	Bore	Pitch Diameter	Outside Diameter	Hub Diameter
			B	E	F	A
			mm/inch	mm	mm	mm

Split Sprockets

Square bores

NS2000-13T_90MM_S_POM	10291188	13	90	212.3	209.0	45
NS2000-16T_65MM_S_POM	10298195	16	65	260.4	262.0	
NS2000-16T_90MM_S_POM	10298196	16	90			
NS2000-16T_120MM_S_POM	10334389	16	120			

Classic Sprockets

Round bores

N2000-10T_40MM_2KW_POM	10334294	10	40	164.4	163.1	20
N2000-10T_50MM_2KW_POM	10334295	10	50	164.4	163.1	
N2000-12T_40MM_2KW_POM	10334299	12	40	196.3	196.3	
N2000-13T_65MM_2KW_POM	10334305	13	65	212.3	209.0	30
N2000-13T_90MM_2KW_POM	10334306	13	90	212.2	209.0	45
N2000-16T_90MM_2KW_POM	10148122	16	90	260.4	262.0	45
N2000-16T_2-1/2IN_2KW_POM	10327972	16	2.5"	260.4	262.0	30

Square bores

N2000-10T_40MM_S_POM	10334296	10	40	164.4	163.1	20
N2000-10T_60MM_S_POM	10334297	10	60	164.4	163.1	30
N2000-10T_65MM_S_POM	10334298	10	65	164.4	163.1	
N2000-12T_40MM_S_POM	10334301	12	40	196.3	196.3	
N2000-12T_60MM_S_POM	10334302	12	60	196.3	196.3	30
N2000-12T_65MM_S_POM	10334303	12	65	196.3	196.3	
N2000-13T_90MM_S_POM	10334310	13	90	212.3	209.0	
N2000-16T_65MM_S_POM	10334314	16	65	260.4	262.0	30
N2000-16T_90MM_S_POM	10334315	16	90	260.4	262.0	45
N2000-16T_120MM_S_POM	10297110	16	120	260.4	262.0	

Il nastro Serie 2010 con passo da 2 pollici può essere usato per un'ampia gamma di applicazioni nell'industria alimentare. Questi nastri sono utilizzati nelle linee di disossamento e taglio e negli elevatori per carichi medio-pesanti. Grazie alle varie versioni e all'ampia gamma di accessori, per ciascuna applicazione di movimentazione degli alimenti è disponibile una soluzione personalizzata.

Caratteristiche

- I moduli sono completamente lisci e non dispongono di ricettacoli chiusi o nascosti. Soprattutto la grande area aperta tra le cerniere sotto alla catena offrono un'ottima accessibilità per le operazioni di pulizia. L'area di ritenzione dei perni è molto facile da pulire e grazie all'assenza di bordi o aree nascoste non vi è il rischio di accumulo di sporco e residui.
- Questo nastro è molto facile da installare e smontare, grazie al sistema di bloccaggio integrato. Servendosi di un cacciavite, l'asta di ritenzione del perno può essere posizionata nella posizione di «bloccaggio» o di «sbloccaggio».
- Le ampie cerniere sotto al nastro hanno un alloggiamento adeguato, che ne riduce la pressione di contatto e l'usura. Il collegamento delle cerniere con la piastra superiore è molto rigido e in tal modo fornisce un'ottima resistenza agli impatti. L'ampio diametro riduce la pressione e l'usura delle cerniere.
- La struttura della ruota di traino e quella del nastro sono state ottimizzate per garantire un'ottima trazione, fino al carico di lavoro massimo del nastro per tutta la sua durata. Le ruote di traino lavorate hanno un'ottima resistenza e consentono un'agevole pulizia.

Programma

2015 Solid Top	Superficie chiusa; consente le operazioni di taglio e disossamento sulla superficie del nastro; offre il miglior supporto per i prodotti delicati ed evita la perdita dei piccoli prodotti
2016 Perforated Top	Area aperta al 20%; consente un drenaggio e un flusso d'aria ottimale insieme a un buon supporto del prodotto, grazie agli alloggiamenti rettangolari
2011 Textured Top	Le piccole sporgenze evitano che i prodotti di piccole dimensioni e congelati aderiscano e scivolino sulla superficie del nastro
Accessori per i nastri	Facchini e sponde laterali rettilinee, "buckets" e curvilinee per elevatori e discensori e altre applicazioni nell'industria alimentare



Nastro serie 2015 FTR



Dolci elevati su nastro 2015



Linea di disossamento polli con nastro 2015



Nastro serie 2015 ISR6



Nastro serie 2015

Solid Top 2015

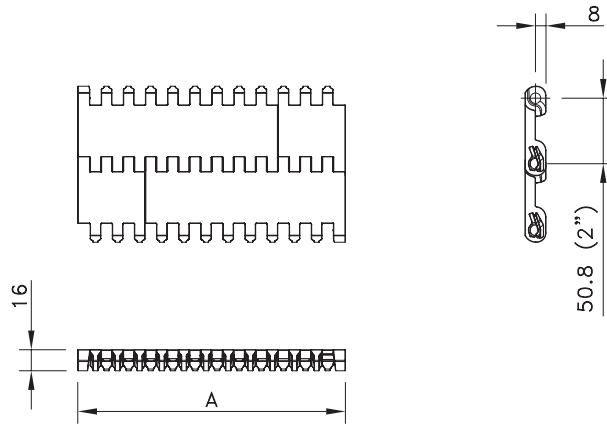
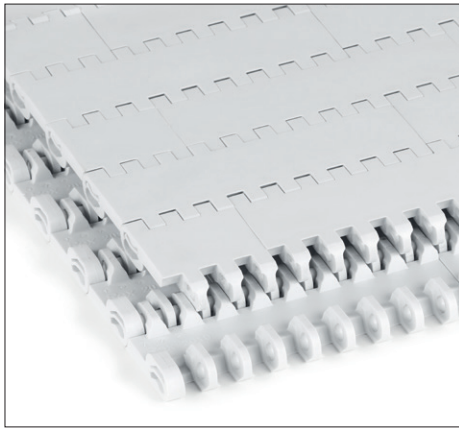

Assembly	Belt Type	Code Number*	Temperature range °C		Working Load (max.) N/m (21°C)	Weight kg/m ²	Backflex Radius (min.) mm
			Dry	Wet			
Polyethylene with Polyethylene Pins							
Standard	WLT 2015	846.04.xx	-70 to +35	-70 to +35	7500	9.50	87
Standard	BLT 2015	846.05.xx	-70 to +35	-70 to +35	7500	9.50	87
Polypropylene with Polypropylene Pins							
Standard	WHT 2015	849.04.xx	4 to 104	4 to 104	15000	8.90	87
Standard	BHT 2015	849.03.6xx	4 to 104	4 to 104	15000	8.90	87
Acetal with Polypropylene Pins							
Standard	WSM 2015	844.03.xx	4 to 80	4 to 65	20000	13.60	87
Standard	SMB 2015	844.02.5xx	4 to 80	4 to 65	20000	13.60	87

Perforated Top 2016

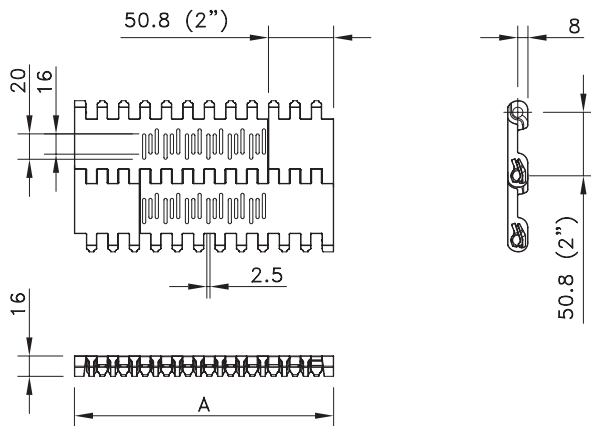
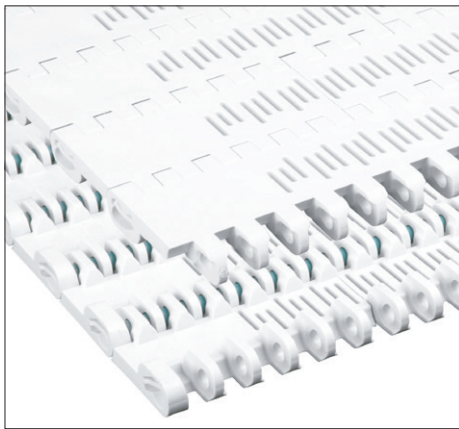

Assembly	Belt Type	Code Number*	Temperature range °C		Working Load (max.) N/m (21°C)	Weight kg/m ²	Backflex Radius (min.) mm
			Dry	Wet			
Polyethylene with Polyethylene Pins							
Mould To Order	WLT 2016	846.07.xx	-70 to +35	-70 to +35	7500	9.50	87
Mould To Order	BLT 2016	846.09.xx	-70 to +35	-70 to +35	7500	9.50	87
Polypropylene with Polypropylene Pins							
Mould To Order	WHT 2016	849.06.xx	4 to 104	4 to 104	15000	8.90	87
Mould To Order	BHT 2016	849.04.xx	4 to 104	4 to 104	15000	8.90	87
Acetal with Polypropylene Pins							
Mould To Order	WSM 2016	844.03.xx	4 to 80	4 to 65	20000	13.60	87
Mould To Order	SMB 2016	844.04.1xx	4 to 80	4 to 65	20000	13.60	87

* Code numbers in the table correspond with 6" wide belts. Code numbers go up with 1 (e.g. 846.07.01, 846.07.02 etc.) for each standard 2" increment (8", 10" etc.) up to 120". Optionally 3/8" increments possible. See also page 208. If you require flights, sideguards or integrated siderail (ISR), please describe the belt by choosing from the options listed in the selection table on page 187.

Textured Top 2011

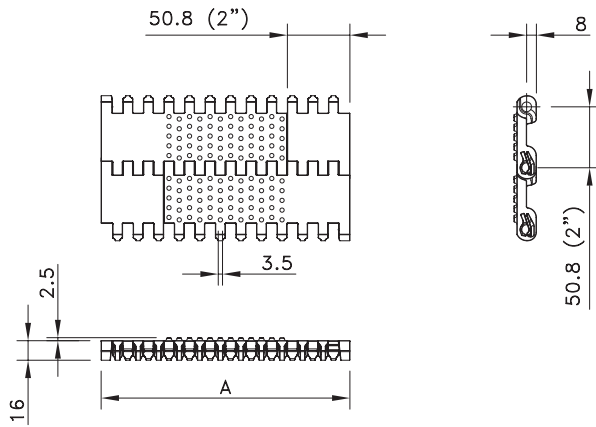
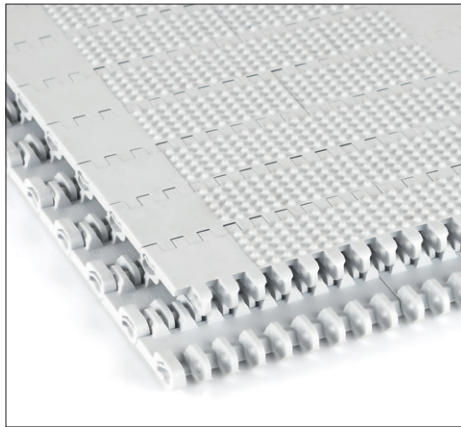

Assembly	Belt Type	Code Number*	Temperature range °C		Working Load (max.) N/m (21°C)	Weight kg/m ²	Backflex Radius (min.) mm
			Dry	Wet			
Polyethylene with Polyethylene Pins							
Mould To Order	WLT 2011	846.07.xx	-70 to +35	-70 to +35	7500	9.50	87
Mould To Order	BLT 2011	846.09.xx	-70 to +35	-70 to +35	7500	9.50	87
Polypropylene with Polypropylene Pins							
Mould to order	WHT 2011	849.06.xx	4 to 104	4 to 104	15000	8.90	87
Mould to order	BHT 2011	849.02.xx	4 to 104	4 to 104	15000	8.90	87
Acetal with Polypropylene Pins							
Mould to order	WSM 2011	844.04.xx	4 to 80	4 to 65	20000	13.60	87
Mould to order	SMB 2011	844.05.xx	4 to 80	4 to 65	20000	13.60	87

* Code numbers in the table correspond with 6" wide belts. Code numbers go up with 1 (e.g. 846.07.52, 846.07.53 etc.) for each standard 2" increment (8", 10" etc.) up to 120". Optionally 1/8" increments possible. See also page 208.

If you require flights or sideguards, please describe the belt by choosing from the options listed in the 2nd column of the table:

Material	WLT, BLT, WHT, BHT, WSM or SMB	
Belt type	2011, 2015 or 2016	
Width (A)	K - in inches	Belts with flights have a minimal width of 8"; smaller upon request
Flights	F1 or F2 or F3 or F4 F5 or F6 C4 or C6 DRF2 or DRF3 or DRF4 or RH.. DRC4 or DRC6 IN B4 or B6	Straight; standard height 1" to 4" or special in mm; all materials available Straight; standard height 5" or 6" Curved; height 4" or 6" Ribbed straight; height 2", 3" or 4" or special in mm Ribbed curved; height 4" or 6" Bucket flight; height 4" or 6"
Pitch between flights	T..P	Flights on every .. th row
Flight side-indent	N.. (in inches)	Minimal 1 1/3" with 2/3" increments; sideguards are situated at 1/3" from the flight, reducing the indent by 2/3"; if side-indent is 1 1/3", sideguards are directly besides the flight, reducing the indent by 1/3"
Sideguards	SG3, SG4 or S2IN	Standard height of 2", 3" or 4"
Integrated Siderail	ISR4 or ISR6	Standard height of 4" or 6" Other sizes up on request. Side Indent in combination with ISR is always 2 2/3" to the flight. Flights are positioned directly against the Integrated Siderail (ISR).

* Flight materials can differ from the belt material in some flight / belt combinations. F5 and F6 are heavy duty flights. Ribbed flights can be double ribbed (both sides) or single rib depending on material and execution.

Example: BLT 2016 K10 SG4 is a 2016 Perforated Top belt, made of blue polyethylene, width 10", no flights and 4" high sideguards.

Example: BHT2015 K24 C6 T4P ISR6, is a SolidTop belt, made of blue Polypropylene, width 24", with 6" high curved pushers every 6th row and 6" high Integrated Siderail (and therefore a side indent of 2 2/3")

Classic Sprockets

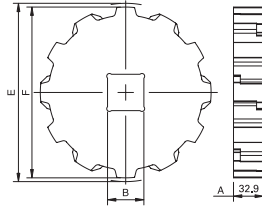

Type	Code Number	Number of Teeth	Bore	Pitch Diameter	Outside Diameter	Hub Width
			B	E	F	A
			mm/inch	mm	mm	mm

Classic Sprockets

Square Bores

Type	Code Number	Number of Teeth	Bore	Pitch Diameter	Outside Diameter	Hub Width
KU2010-6T_40MM_S_UH	10362467	6*	40	101.6	87.0	33
KU2010-8T_40MM_S_UH	10332105	8	40	132.8	121.0	
KU2010-10T_40MM_S_UH	10332108	10	40	164.4	154.0	
KU2010-10T_60MM_S_UH	10333216	10	60			
KU2010-12T_40MM_S_UH	10332111	12	40	196.3	188.0	
KU2010-12T_60MM_S_UH	10333219	12	60			

* 6 teeth sprockets are not recommended as drive sprockets.

Accessory Information:

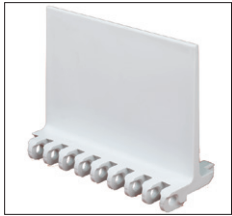

Straight Flight for 2010-Series

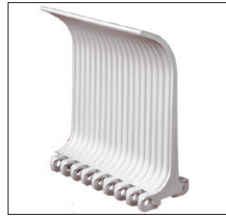
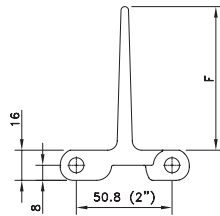

Curved Ribbed Flight for 2010-Series

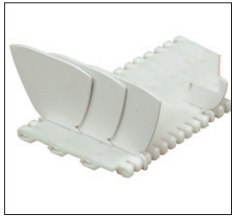
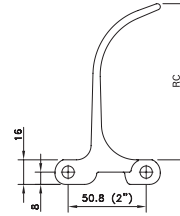

Sideguards for 2010-Series

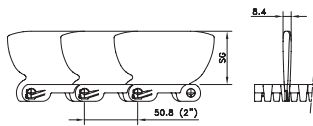

Bucket Flight for 2010-Series

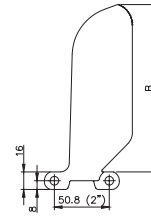

Le catene MatTop Serie 6990 con passo da 2¼ pollici sono destinate principalmente ai trasportatori lunghi e larghi nei settori dell'industria automobilistica, senza dover effettuare alcun tensionamento. La tecnologia 6990 è adatta per ridurre al minimo l'altezza totale della costruzione del nastro trasportatore, evitando quindi delle costruzioni con pozzetto profondo. L'elevata capacità di carico di questi nastri consente la movimentazione di persone e automobili nelle catene di montaggio, nelle applicazioni di collaudo di impermeabilità e perdite d'acqua, e negli autolavaggi. La serie 6990 è disponibile in plastica e nelle versioni definite ibride che aumentano il livello di prestazioni delle catene modulari in plastica. Si possono realizzare nastri trasportatori lunghi fino a 200 metri. Di serie, i nastri vengono forniti in acetilica ad elevate prestazioni, con una superficie chiusa o con una superficie superiore sicura (antiscivolo).

Caratteristiche

- Elevata capacità di carico fino a 50.000 N/m con perni standard e oltre 70.000 N/M con perni in PBT.
- Cerniere equamente spaziate per una maggiore rigidità della catena.
- Catena progettata per durare a lungo, grazie a un perno con diametro maggiorato, a una larghezza ottimale della cerniera e a un design resistente collaudato per la parte sotto della catena.
- Semplicità d'installazione e manutenzione grazie al sistema di ritenzione del perno Twist-Lock® su entrambi i lati, facile da operare con un semplice cacciavite ed evitare la perdita di spinotti; auto-chiudente grazie al peso della catena.
- Disponibile di serie in acetilica BSM e BYSM con lati in colore giallo ad indicare chiaramente il bordo della catena in movimento, per una maggiore sicurezza; su richiesta, è disponibile anche una versione con i bordi rossi.
- Tecnologia di trasmissione di alta qualità anche in condizioni di carico elevato, grazie a un design specifico delle sedi di ingranamento e della ruota di traino.
- Facchinetti a resistenza elevata disponibili per l'utilizzo in autolavaggi e nel settore automobilistico.

Caratteristiche	Serie 6990 Rexnord Catena MatTop	Serie 6990 Rexnord Catena MatTop ibrida
Elevata capacità di carico	Una distribuzione elevata del carico fino a 50.000 N/m con perni standard in polipropilene, oltre 70.000 N/m con perni in PBT.	Maggiore livello di prestazioni per carichi elevati, variazioni frequenti del carico (sistemi trasportatori per persone). Distribuzione del carico su N/m con piastre di tensionamento in acciaio e perni in acciaio.
Maggiore rigidità della catena	Cerniere equamente spaziate per un design robusto.	Struttura in acciaio integrata in grado di creare rigidità e resistenza elevate. Funzionamento corretto della catena che elimina l'effetto scivolamento-incollamento o pulsazione. Realizzazione di nastri trasportatori di oltre 200 mt in applicazioni per lo spostamento di persone, veicoli o combinazioni.
Design della catena resistente all'abrasione	Perno con diametro maggiorato Larghezza della cerniera ottimale e design resistente collaudato della parte inferiore della catena.	Perno in acciaio e piastre di usura garantiscono una resistenza estrema all'usura
Semplicità di installazione e manutenzione	Sistema di ritenzione del perno Twist-Lock® per evitare la perdita dei tappi. Effetto auto chiudente grazie al peso della catena e facile da operare con un semplice cacciavite.	Nessun ingrassaggio o tensionamento della catena. Twist-Lock® in metallo per evitare la perdita dei perni in acciaio. Effetto auto chiudente grazie al peso della catena e facile da operare con un semplice cacciavite.
Sicurezza	Lati gialli o rossi per mostrare facilmente il bordo della catena in movimento e con indicazione della zona di contatto del nastro. Disponibile in materiale ignifugo.	Lati gialli o rossi per mostrare facilmente il bordo della catena in movimento, quindi migliorare la sicurezza, e con indicazione della zona di contatto del nastro. Lo standard ESD ha la più bassa resistività di superficie di tutte le catene modulari in plastica della concorrenza (< 10 ¹ Ohms/m ² , NEN-EN-IEC 61340-4-5). Disponibile in materiale ignifugo.
Tecnologia di traino di alta qualità	Funzionamento silenzioso grazie a un design specifico delle sedi di ingranamento e della ruota di traino.	Ruota dentata di traino modello H dove i denti della ruota dentata si trovano a sinistra e a destra della struttura ibrida in acciaio. Espansione della temperatura limitata (solo il 10% di un equivalente in plastica).
Facchinetti a resistenza elevata	Disponibili standard per autolavaggi e applicazioni del settore automobilistico.	Disponibili standard per autolavaggi e applicazioni del settore automobilistico.

Programme	
6995 Solid Top	Superficie chiusa; adatta per le applicazioni in campo automobilistico e per gli spostamenti delle persone.
6999 Safety Top	Superficie chiusa antiscivolo; contrasta la scivolosità in ambienti umidi, oleosi o bagnati.
Versione H4 ibrida 6990 H4 o H8	Con quattro (H4) o otto (H8) piastre di tensionamento per modulo. Il modello H4 è progettato per funzionare su fogli UHMWPE in profili a rullo ESD o Denirug®. Il modello H8 è progettato per applicazioni estreme (carichi elevati, maggiore rigidità della catena) che richiedono un funzionamento eccellente.
6990 ESD4	Questa catena è costruita interamente in plastica per nastri trasportatori che richiedono prestazioni ad alta dissipazione elettrostatica (ESD) con quattro piastre di tensionamento per modulo.
Materiali dei moduli	BSM Acetalica
	FR/FRES Ignifugo, soddisfa la norma DIN 4102-B1
Accessori per i nastri	Facchinetti per il settore automobilistico T1 e T2 con misure espresse in pollici. Questi facchinetti soddisfano i requisiti dello standard DIN24446. I facchinetti possono essere abbinati a protezioni laterali alte 40 mm. Le protezioni laterali sono disponibili esclusivamente attraverso canali dell'industria selezionati.
Ruote di traino	Le ruote di traino lavorate sono disponibili in diversi formati in plastica o acciaio inox; ruote di traino 6990-9 fino a 14 denti e ruote di traino ibride 6990 (da 9 fino a 20 denti). ; contattare ingegneria.

Solid Top 6995

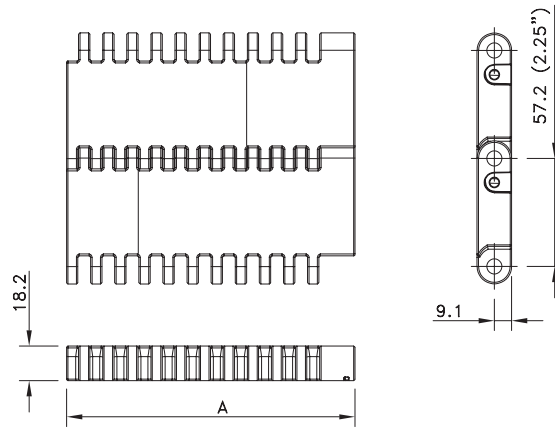
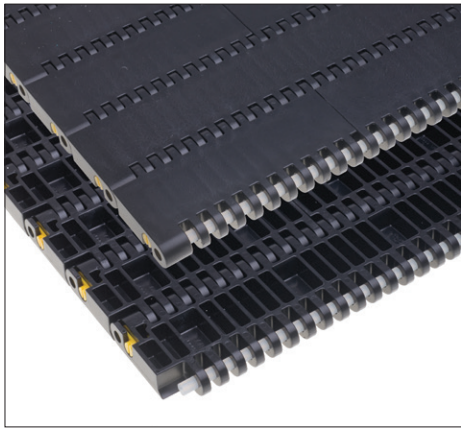

Assembly	Belt Type	Code Number*	Temperature range °C		Working Load (max.) N/m (21°C)	Weight kg/m ²	Backflex Radius (min.) mm
			Dry	Wet			
BSM-Acetal With Polypropylene Pins							
Standard	BSM 6995	I6995BSMKxx	4 to +80	4 to +65	51000	14.65	63.5
BYSM-Acetal With Polypropylene Pins							
Standard	BYSM 6995	I6995BYSMKxx	4 to +80	4 to +65	51000	14.65	63.5

Safety Top 6999

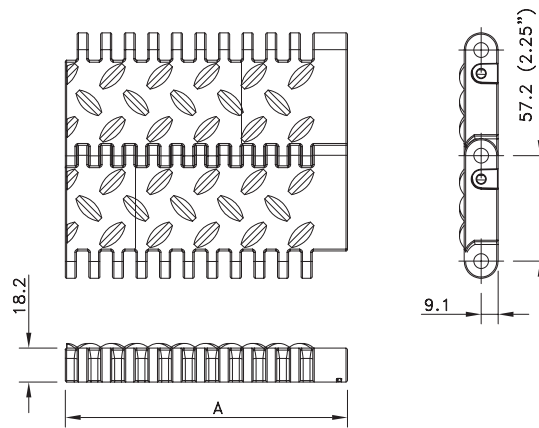
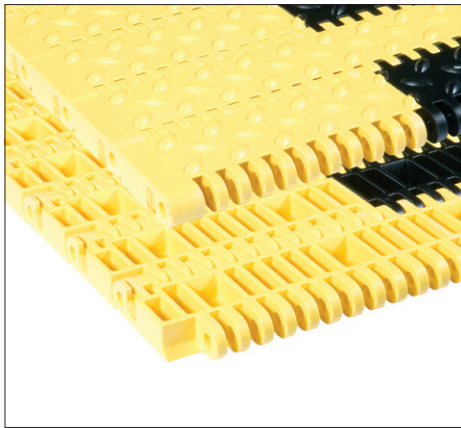

Assembly	Belt Type	Code Number*	Temperature range °C		Working Load (max.) N/m (21°C)	Weight kg/m ²	Backflex Radius (min.) mm
			Dry	Wet			
BSM-Acetal With Polypropylene Pins							
Standard	BSM 6999	I6999BSMKxx	4 to +80	4 to +65	51000	14.65	63.5
BYSM-Acetal with Polypropylene Pins							
Standard	BYSM 6999	I6999BYSMKxx	4 to +80	4 to +65	51000	14.65	63.5

* In code numbers xx corresponds with the belt width (A). Standard widths of these belts begin at 9" with 6" increments up to 190"; special widths begin at 5" with 1/2" increments. See also page 223.

Split Sprockets



Classic Sprockets

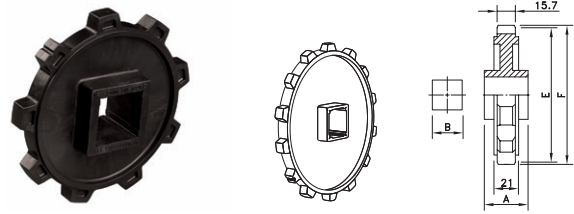

Sprocket Type	Code Number	Number of Teeth	Bore	Pitch Diameter	Outside Diameter	Hub Width
			B	E	F	A
			mm/inch	mm	mm	mm

Split Sprockets

Square Bores

Sprocket Type	Code Number	Number of Teeth	Bore	Pitch Diameter	Outside Diameter	Hub Width
NS5996-9T_90MM_S_PA	10027448	9	90	167.1	164.1	48
NS5996-12T_90MM_S_PA	10027449	12	90	220.8	221.0	
NS5996-14T_90MM_S_PA	10028558	14	90	256.8	256.5	
NS5996-14T_120MM_S_PA	10131451	14	120			

Classic Sprockets

Square Bores

Sprocket Type	Code Number	Number of Teeth	Bore	Pitch Diameter	Outside Diameter	Hub Width
N5996-7T_40MM_S_POM	10013574	7	40	167.1	164.1	48
N5996-9T_40MM_S_HS	10012700	9	40			
N5996-9T_50MM_S_HS	10071980	9	50			
N5996-9T_65MM_S_HS	10070046	9	65	256.8	256.5	
N5996-14T_40MM_S_HS	10070601	14	40			
N5996-14T_50MM_S_HS	10070602	14	50			
N5996-14T_65MM_S_HS	10069276	14	65			
N5996-14T_90MM_S_HS	10012489	14	90			

HS suitable for hot and humid applications.

Accessory:



DIN Style Pusher 6990

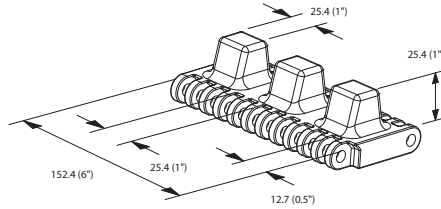

T1 Dimensions

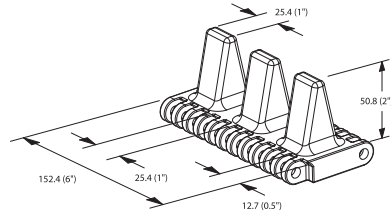

T2 Dimensions



DIN Style Sideguard 6990

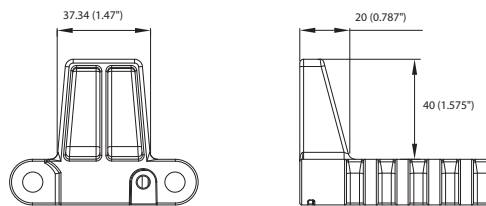

H40 Dimensions

Solid Top 6995 H4

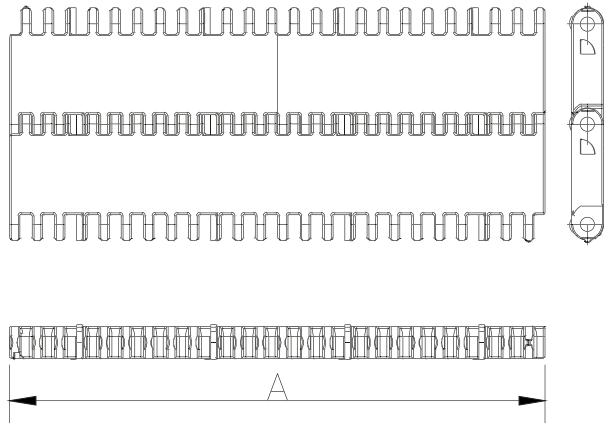
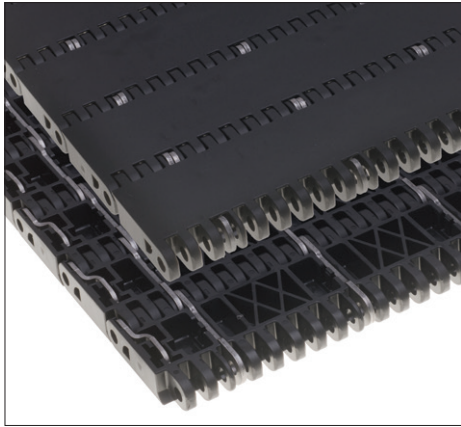

Chain Type	Code Number	Working Load (max)		Weight		Backflex Radius (min)		Certification
		lbs/ft / N/m		Lbs/ft ² / kg/m ²		in / mm		
BM - With Stainless Steel Pins								
BM6995H4	I6995H4BMKxx	6.850 / 100.000		5.1 / 25		1.75 / 45		NEN-EN-IEC 61340-4-5
FR-PA - With Stainless Steel Pins								
FR-PA6995H4	I6999H4FRKxx	6.850 / 100.000		4.7 / 23.2		1.75 / 45		NEN-EN-IEC 61340-4-5 DIN4102-B1 (Bfl -s1)

Kxx indicated the chain width (K12, K14,.....K228). BM Chain width available starting at 12-inches (306 mm) up to 234,9 inch (5967 mm) actual width with increments of 3 inches (76,5 mm).

Kxx indicated the chain width (K12, K14,..... K228). FR-PA Chain width available starting at 12,1- inches (308 mm) up to 236,5 inch (6006 mm) actual width with increments of 3,1 inches (77 mm).

Safety Top 6999 H4

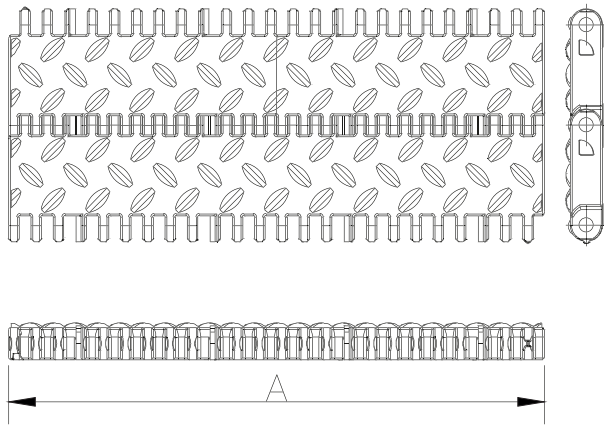
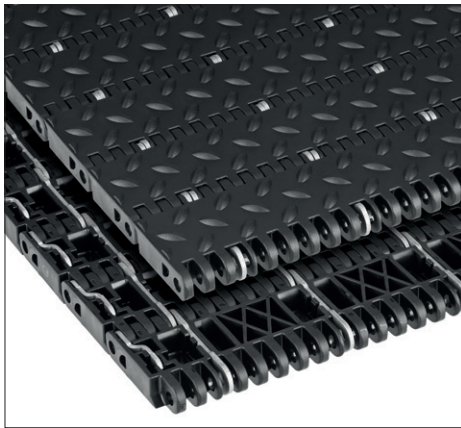

Chain Type	Code Number	Working Load (max)		Weight		Backflex Radius (min)		Certification
		lbs/ft	N/m	Lbs/ft ²	kg/m ²	in	mm	
BM - With Stainless Steel Pins								
BM6999H4	I6999H4BMKxx	6.850	100.000	5.2	25.4	1.75	45	NEN-EN-IEC 61340-4-5
FR-PA - With Stainless Steel Pins								
FR-PA6999H4	I6999H4FRKxx	6.850	100.000	4.7	23.6	1.75	45	NEN-EN-IEC 61340-4-5 DIN4102-B1 (Bfl-s1)

Kxx indicated the chain width (K12, K14,.....K228). BM Chain width available starting at 12-inches (306 mm) up to 234,9 inch (5967 mm) actual width with increments of 3 inches (76,5 mm).

Kxx indicated the chain width (K12, K14,..... K228). FR-PA Chain width available starting at 12,1- inches (308 mm) up to 236,5 inch (6006 mm) actual width with increments of 3,1 inches (77 mm).

Solid Top 6995 H8

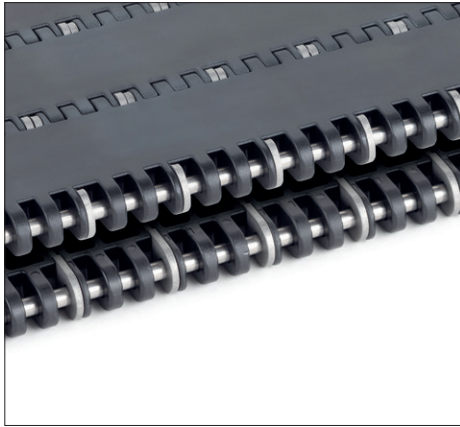

Chain Type	Code Number	Working Load (max)		Weight		Backflex Radius (min)		Certification
		lbs/ft / N/m		Lbs/ft2 / kg/m2		in / mm		
BM								
BSM6995H8	I6995H8BMKxx	11.645 / 170.000		6.2 / 30.2		1.75 / 45		NEN-EN-IEC 61340-4-5
FR-PA - With Stainless Steel Pins								
FR-PA6995H8	I6999H8FRKxx	11.645 / 170.000		5.8 / 28.2		1.75 / 45		NEN-EN-IEC 61340-4-5 DIN4102-B1 (Bfl-s1)

Kxx indicated the chain width (K12, K14,.....K228). BM Chain width available starting at 12-inches (306 mm) up to 234,9 inch (5967 mm) actual width with increments of 3 inches (76,5 mm).

Kxx indicated the chain width (K12, K14,..... K228). FR-PA Chain width available starting at 12,1- inches (308 mm) up to 236,5 inch (6006 mm) actual width with increments of 3,1 inches (77 mm).

Safety Top 6999 H8

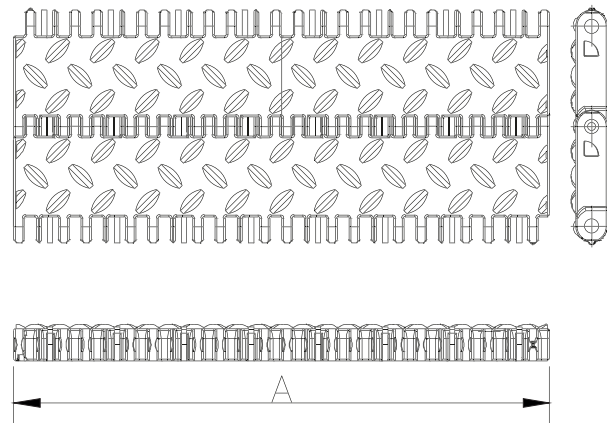

Chain Type	Code Number	Working Load (max)		Weight		Backflex Radius (min)		Certification
		lbs/ft	N/m	Lbs/ft2	kg/m2	in	mm	
BM								
BSM6999H8	I6999H8BMKxx	11.645	170.000	6.3	30.6	1.75	45	NEN-EN-IEC 61340-4-5
FR-PA - With Stainless Steel Pins								
FR-PA6999H8	I6999H8FRKxx	11.645	170.000	5.9	28.8	1.75	45	NEN-EN-IEC 61340-4-5 DIN4102-B1 (Bfl-s1)

Kxx indicated the chain width (K12, K14,.....K228). BM Chain width available starting at 12-inches (306 mm) up to 234,9 inch (5967 mm) actual width with increments of 3 inches (76,5 mm).

Kxx indicated the chain width (K12, K14,..... K228). FR-PA Chain width available starting at 12,1- inches (308 mm) up to 236,5 inch (6006 mm) actual width with increments of 3,1 inches (77 mm).

Perforated Top 6992 HYB H4

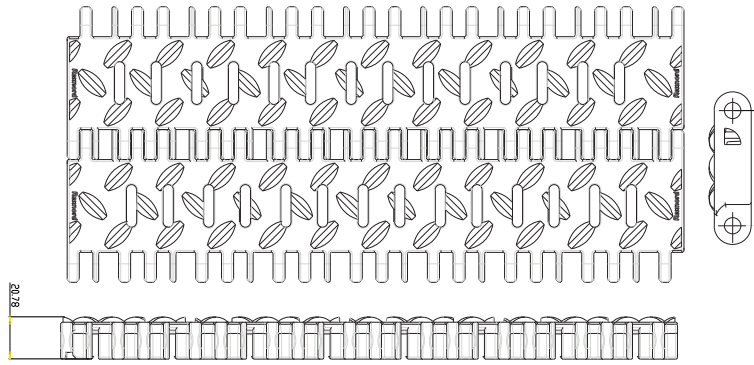

Chain Type	Code Number	Working Load (max)		Weight		Backflex Radius (min)		Certification
		lbs/ft / N/m		Lbs/ft ² / kg/m ²		in / mm		
BM - With Stainless Steel Pins								
BM6992H4	I6992BMKXX	3.427 / 50.000		3.40 / 16.76		3.00 / 76.2		NEN-EN-IEC 61340-4-5
BM6992ESD4	I6992ESD4BMKXX	6.850 / 100.000		5.20 / 25.00		3.00 / 76.2		NEN-EN-IEC 61340-4-5

Kxx indicated the chain width (K12, K14,.....K228). BM Chain width available starting at 12-inches (306 mm) up to 234,9 inch (5967 mm) actual width with increments of 3 inches (76,5 mm).

Perforated Top 6992 HYB H8

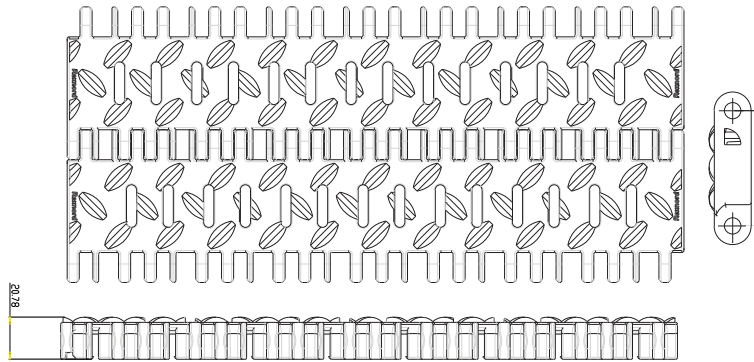

Chain Type	Code Number	Working Load (max)		Weight		Backflex Radius (min)		Certification
		lbs/ft	N/m	Lbs/ft ²	kg/m ²	in	mm	
BM - With Stainless Steel Pins								
BSM6999H8	I6999H8BMKxx	6.850	100.000	5.2	25.4	3.00	76.2	NEN-EN-IEC 61340-4-5

Kxx indicated the chain width (K12, K14,.....K228). BM Chain width available starting at 12-inches (306 mm) up to 234,9 inch (5967 mm) actual width with increments of 3 inches (76,5 mm).

Solid Top 6995 ESD4

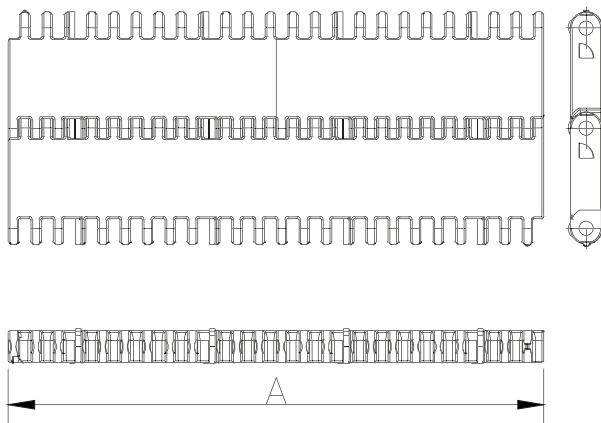

Chain Type	Code Number	Working Load (max)	Weight	Backfl ex Radius (min)	Certification
		lbs/ft / N/m	Lbs/ft2 / kg/m2	in / mm	
BM - With PP Pins					
BM6995ESD4	I6995ESD4BMKxx	3.427 / 50.000	3.40 / 16.76	3.00 / 76.2	NEN-EN-IEC 61340-4-5
FR-PA - With PP Pins					
FR-PA6995ESD4	I6995ESD4FRPAKxx	2.937 / 42.857	2.82 / 13.89	3.00 / 76.2	NEN-EN-IEC 61340-4-5 DIN4102-B1 (Bfl -s1)

Kxx indicated the chain width (K12, K14,.....K228). BM Chain width available starting at 12-inches (306 mm) up to 234,9 inch (5967 mm) actual width with increments of 3 inches (76,5 mm).

Kxx indicated the chain width (K12, K14,..... K228). FR-PA Chain width available starting at 12,1- inches (308 mm) up to 236,5 inch (6006 mm) actual width with increments of 3,1 inches (77 mm).

Safety Top 6999 ESD4

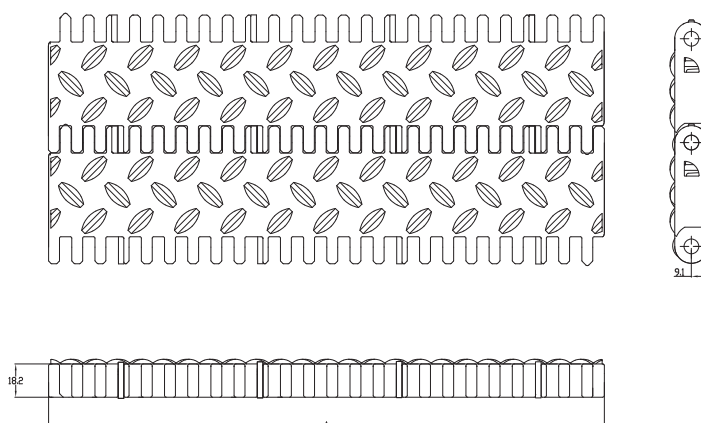

Chain Type	Code Number	Working Load (max)	Weight	Backfl ex Radius (min)	Certification
		lbs/ft / N/m	Lbs/ft2 / kg/m2	in / mm	
BM - With PP Pins					
BM6999ESD4	I6999ESD4BMKxx	3.427 / 50.000	3.49 / 17.20	3.00 / 76.2	NEN-EN-IEC 61340-4-5
FR-PA - With PP Pins					
FR-PA6999ESD4	I6999ESD4FRPAKxx	2.937 / 42.857	2.89 / 14.26	3.00 / 76.2	NEN-EN-IEC 61340-4-5 DIN4102-B1 (Bfl -s1)

Kxx indicated the chain width (K12, K14,.....K228). BM Chain width available starting at 12-inches (306 mm) up to 234,9 inch (5967 mm) actual width with increments of 3 inches (76,5 mm).

Kxx indicated the chain width (K12, K14,..... K228). FR-PA Chain width available starting at 12,1- inches (308 mm) up to 236,5 inch (6006 mm) actual width with increments of 3,1 inches (77 mm).

KU6990 Hybrid

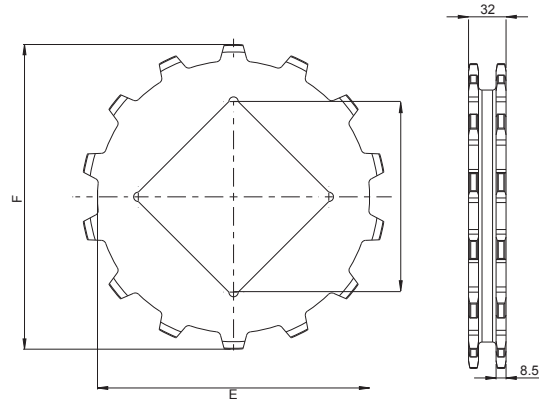
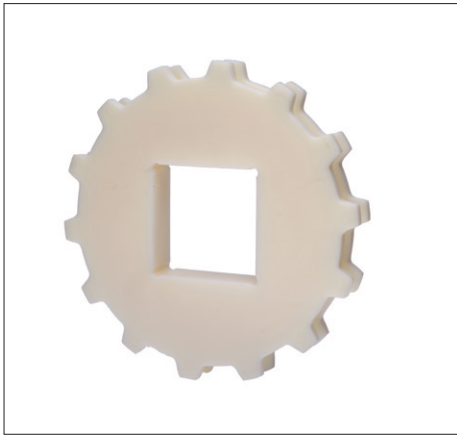

Sprocket Description	Number Of Teeth	Pitch Circle Diameter	Maximum Square Bore Size	Hub Width
		inch / mm	inch / mm	inch / mm
Solid				
KU6990 Hybrid T09	9	168,85	60	32
KU6990 Hybrid T12	12	223,13	110	32
KU6990 Hybrid T14	14	259,53	140	32
KU6990 Hybrid T16	16	296,02	160	32
KU6990 Hybrid T17	17	314,29	170	32
KU6990 Hybrid T19	19	350,86	200	32
Split				
KUS6990 Hybrid T09	9	168,85	60	32
KUS6990 Hybrid T12	12	223,13	110	32
KUS6990 Hybrid T14	14	259,53	140	32
KUS6990 Hybrid T16	16	296,02	160	32
KUS6990 Hybrid T17	17	314,29	170	32
KUS6990 Hybrid T19	19	350,86	200	32

Other bore sizes, teeth and round bores are available on request. Please consult our technical support department for more information.

Il nastro con passo da 3 pollici Serie 3120 è la catena modulare di plastica più resistente di Rexnord, utilizzata principalmente per applicazioni di tipo industriale, compresi i trasportatori per il cambio dell'olio, i trasportatori finali della catena di montaggio a 2 corsie, il trasporto su pattini e bancali, i trasportatori di prova su acqua a 2 corsie e i trasportatori per il trasporto di componenti per auto. La catena è stata inoltre testata in applicazioni di autolavaggio su corsia singola, sostituendo la tecnologia convenzionale. Il nastro è stampato in acetilica e utilizza tappi brevettati TwistLock® e perni in poliestere con diametro da ½ pollice. Questa catena è disponibile anche con un facchinetto T2 (2 pollici), e garantisce il trasporto controllato di veicoli di qualsiasi dimensione su una catena larga 12 pollici. La ruota di traino disponibile ha una struttura ad H (2 file di denti per ciascuna ruota di traino) per carichi di grandi dimensioni.

Caratteristiche

- Capacità di carico ultra elevata di 115,000 N/m (è disponibile la catena in plastica MatTop più resistente). Non è necessario che i perni in acciaio (inossidabile) raggiungano il carico di lavoro massimo riducendo il peso globale della catena e i consumi elettrici.
- La combinazione di cerniere suddivise in modo uniforme con perni da ½ pollice di diametro fornisce una rigidità estremamente elevata.
- Design a lunga durata grazie ai perni di grande diametro, occhiello della cerniera ottimale e struttura collaudata resistente all'usura del lato inferiore della catena (grande superficie di contatto).
- Agevole installazione e manutenzione in combinazione con ritenzione a perni Twist-Lock a entrambi i lati, facilmente utilizzabili mediante un semplice cacciavite, senza perdere i tappi; chiusura automatica sotto il peso della catena.
- Tecnologia di trasporto di alta qualità, anche sotto carichi e cicli di lavoro pesanti, grazie a un ricettacolo del nastro specifico e alla struttura della ruota di traino.
- Sono disponibili dei facchinetti ad elevata resistenza per uso in campo automobilistico e industriale.
- Disponibili in SolidTop (3125), SafetyTop (3129) e RubberTop 3125 per soddisfare qualsiasi tipo di applicazione.
- Disponibili in BSM e BYSM con i lati di color giallo. A richiesta disponibili anche con lati di colore diverso.
- Facchini T1-pollice e T2-pollice ad alta resistenza e sponde alte H40 mm per uso industriale e settore automobilistico.
- Facchinetti e sponde soddisfano i criteri della norma DIN24446.
- La catena può essere fornita con T1 o T2 facchino o sponde laterali, si prega di indicare il passo dei facchini T1 o T2 (Esempio T18P si intende ogni 18° passo). Indent laterale SG40. L'indent laterale minimo con il facchino è ½" con incremento di 2"
- Catena standard fornita con perno in poliestere (PBT). A richiesta possibilità di montare altri tipi di perni in plastica oppure in acciaio inossidabile .

Programme	
3125 Solid Top	Superficie chiusa; adatto per le applicazioni in campo automobilistico e per gli spostamenti delle persone.
3129 SafetyTop	Superficie chiusa antiscivolo; contrasta la scivolosità in ambienti bagnati ed oleosi.
Accessori	Su richiesta, sono disponibili facchinetti T1 e T2, con unità di misura espresse in pollici.



3125 T2 mattop carwash



3125 T2 din facchino Mattop

Solid Top 3125

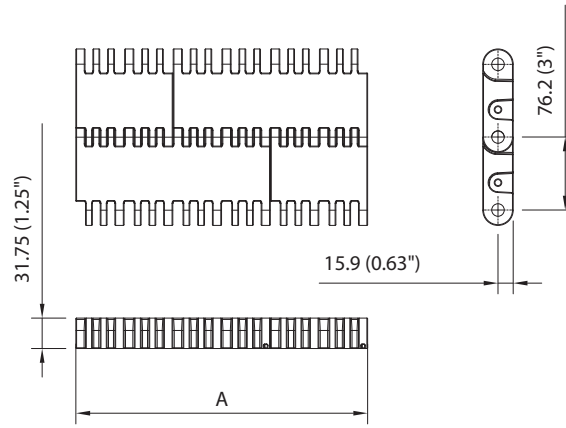
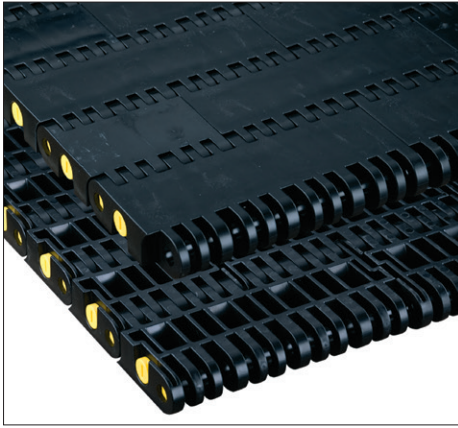

Assembly	Belt Type	Code Number*	Temperature range °C		Working Load (max.) N/m (21°C)	Weight kg/m ²	Backflex Radius (min.) mm
			Dry	Wet			
Acetal With Polyester Pins							
Standard	BSM 3125	I3125BSMKxx	-30 to +80	up to 65	115000	31.10	76.2
Standard	BYSM 3125	I3125BYSMK					

Safetytop 3129

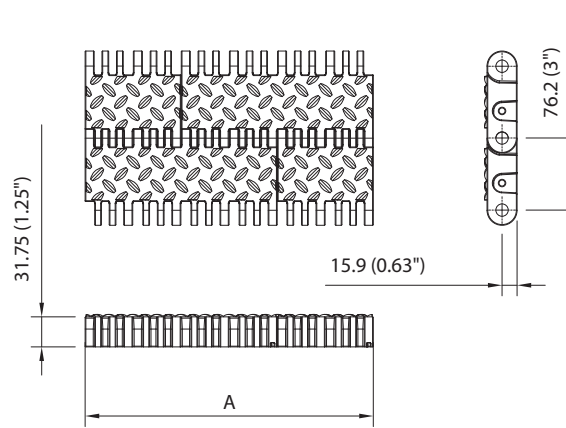
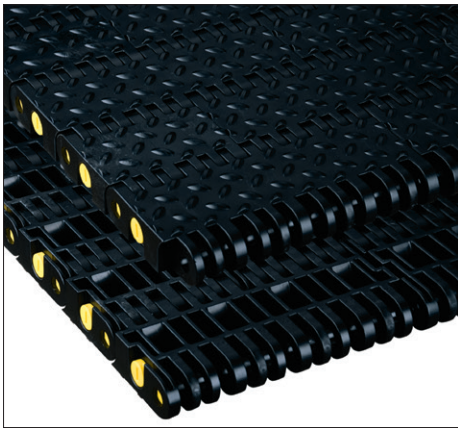

Assembly	Belt Type	Code Number*	Temperature range °C		Working Load (max.) N/m (21°C)	Weight kg/m ²	Backflex Radius (min.) mm
			Dry	Wet			
Acetal With Polyester Pins							
Standard	BSM 3129	I3129BSMKxx	-30 to +80	up to 65	115000	31.10	76.2
Standard	BYSM 3129	I3129BYSMKxx					

* In code numbers xx correspond with the belt width (A). Standard width of these belts begin at 4" with 2" increments up to 190"; 4" and 8" execution are mold-to-width executions. See page 223.

BSM3125-K4 MTW

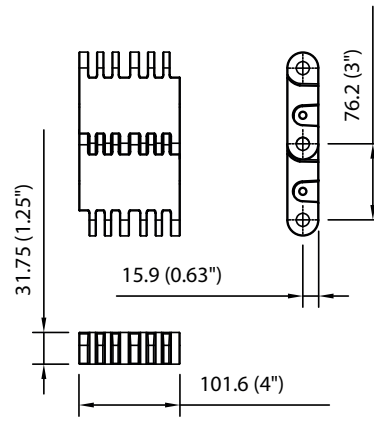
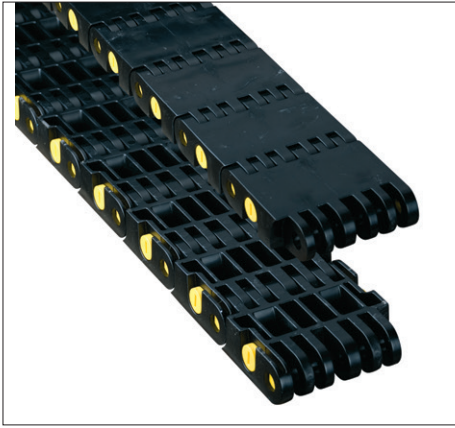

Assembly	Belt Type	Code Number*	Temperature range °C		Working Load (max.) N (21°C)	Weight kg/m ²	Backflex Radius (min.) mm
			Dry	Wet			
Acetal With Polyester Pins							
Standard	BSM 3125 K4	I3125BSMK004	-30 to +80	up to 65	115000	31,10	76,2

Rubber Top 3125-K4

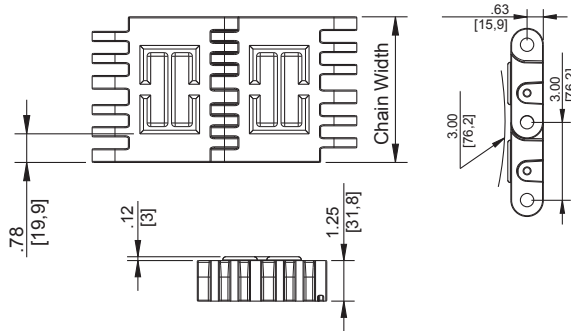

Assembly	Belt Type	Code Number*	Temperature range °C		Working Load (max.) N (21°C)	Weight kg/m ²	Backflex Radius (min.) mm
			Dry	Wet			
Acetal With Polyester Pins							
Standard	BSM 3125 RT-K4 MTW	876.29.10	-30 to +80	up to 65	115000	31,10	76,2
Standard	BSM 3185 RT-K3.2 MTW	I3185BSM3.2 -30	-30 to +80	up to 65	115000	31,10	76,2

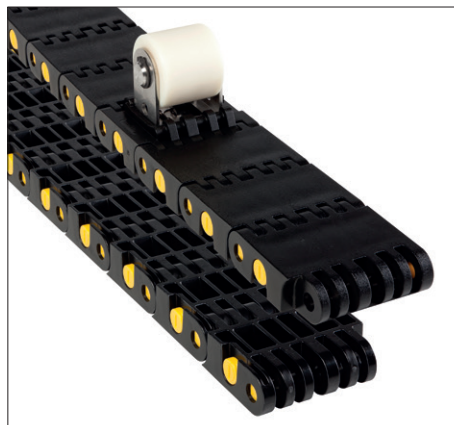
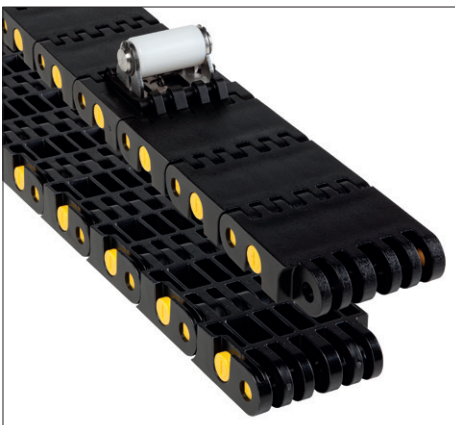

Rexnord BM3120 Universal Bracket Standard_30mm

Rexnord BM3120 Universal Bracket Standard_60mm

Solid Top 3185-K3.2 MTW

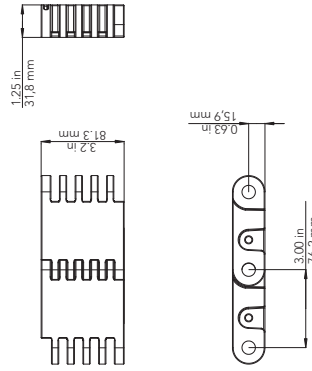

Assembly	Belt Type	Code Number*	Temperature range °C		Working Load (max.) N/m (21°C)	Weight kg/m ²	Backflex Radius (min.) mm
			Dry	Wet			
Acetal With Polyester Pins							
Standard	BSM 3185 K3.2	I3125BSMK004	-30 to +80	up to 65	115000	31.10	76.2

Safetytop 3185-K3.2 Rubber Top

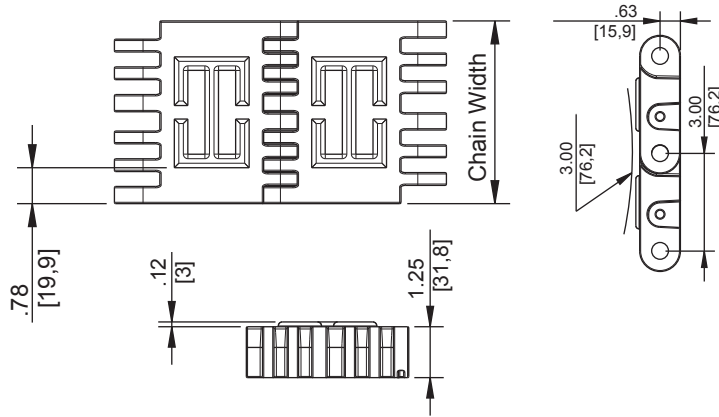

Assembly	Belt Type	Code Number*	Temperature range °C		Working Load (max.) N/m (21°C)	Weight kg/m ²	Backflex Radius (min.) mm
			Dry	Wet			
Acetal With Polyester Pins							
Standard	BSM 3185 RT-K3.2 MTW	I3185BSM3.2 -30	-30 to +80	up to 65	115000	31.10	76.2

Progettate per percorsi lunghi e carichi pesanti, le catene Rexnord 3125-4IN MTW HYB Serie MatTop e la Rexnord 3122 HYB MatTop sono la soluzione preferita. Il design include perni (aste) in solido acciaio inox e 12 piastre di tensionamento in acciaio inox per giunzione. La costruzione fornisce una rigidità superiore e una robustezza alla fatica che migliora le proprietà di scorrimento, mitiga la vibrazione e fornisce una maggiore durata di vita della catena.

Il nostro design di catena per funzioni gravose per nastri trasportatori con carichi pesanti

La catena Rexnord 3125-4IN MTW HYB Serie MatTop è progettata per i nastri trasportatori a pattino da 4 pollici (101 mm). La superficie del Rexnord 3125-4IN MTW SolidTop consente l'allineamento meccanico dei pattini prima del trasferimento al nastro trasportatore successivo. La caratteristica di RubberTop® garantisce il corretto posizionamento dei pattini nelle frequenti operazioni di avvio e arresto; ne sono un esempio i sistemi a tampone tra il reparto di verniciatura e il reparto di assemblaggio.

La catena Serie Rexnord 3122- HYB MatTop viene offerta nella versione con superficie superiore di sicurezza antiscivolo con perforazioni per il drenaggio in ambienti umidi e ventilazione nelle aree d'ispezione.



Sistema trasportatore dotato di Catena Rexnord 3125 HYB 12 Serie MatTop.

3122HYB (MTW)



Photo shows 3122HYB (MTW) MatTop Chain molded in Black (BM) material.

Chain Information

Chain Width			Number of Sprockets	Chain Strength	
desc	in	mm		lbs	N
4	4.0	101.6	1	6,000	26689

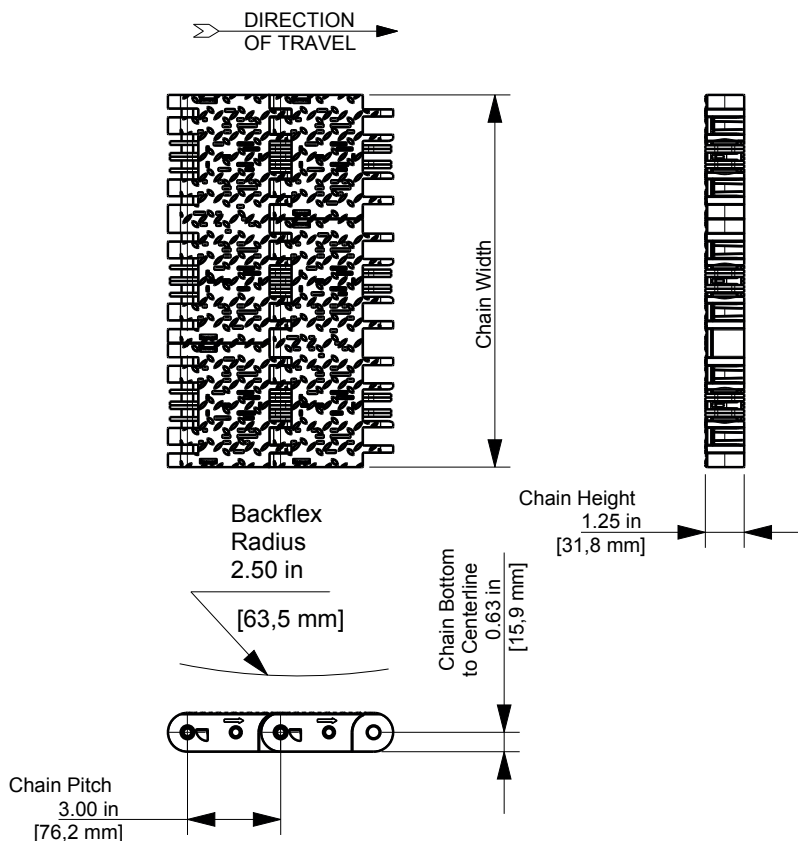

Available Materials

Prefix	Chain Material	Standard Pin Material	Temperature						Approximate Weight		FDA Approval
			Fahrenheit			Celsius					
			min	max		min	max		lbs/ft ²	Kg/m ²	
Standard Materials											
BM	Black Material	Stainless Steel	-40	+180	+150	-40	+82	+66	11.61	56.67	Yes
FR-PA	Flame retardant Nylon (Black)	Stainless Steel	-40	+220	NR	-40	+104	NR	11.33	55.32	No

3125-4IN MTW H12 RubberTop

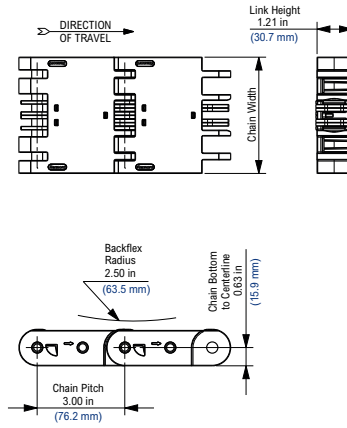
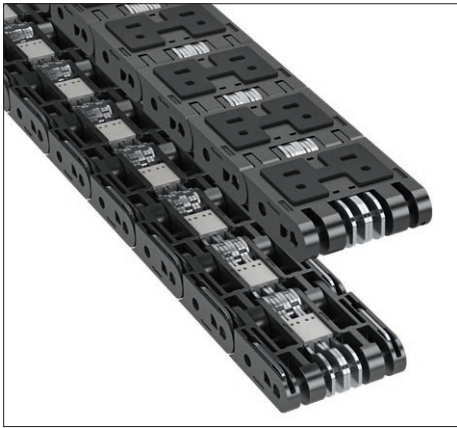

3125-4IN MTW HYB RubberTop Series MatTop Chain

Prefix	Chain Material	Standard Pin Material	Temperature						Chain Strength		Approximate Weight	
			Fahrenheit			Celsius						
			min	max		min	max		lbs/ft	N/m	lbs/ft ²	Kg/m ²
Standard Materials												
BM	Black Material	Stainless Steel	-40	+180	+150	-40	+82	+66	18,000	262,690	11.61	56.67
BYM	Yellow Material	Stainless Steel	-40	+180	+150	-40	+82	+66	18,000	262,690	11.61	56.67

3125-4IN MTW H12 FlatTop

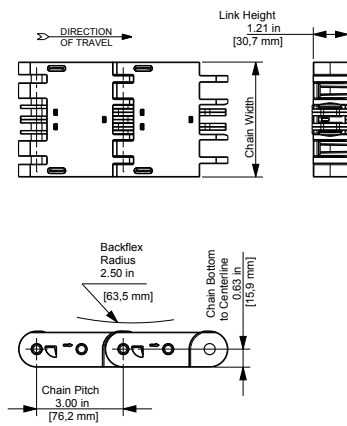
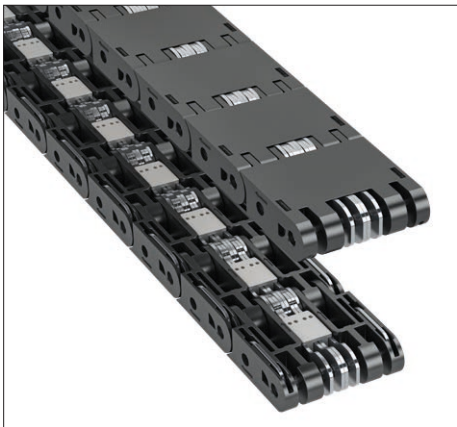

Rexnord 3125-4IN MTW H12 Series MatTop Chain

Prefix	Chain Material	Standard Pin Material	Temperature						Chain Strength		Approximate Weight	
			Fahrenheit			Celsius						
			min	max		min	max		lbs/ft	N/m	lbs/ft ²	Kg/m ²
Standard Materials												
BM	Black Material	Stainless Steel	-40	+180	+150	-40	+82	+66	18,000	262,690	11.61	56.67
BYM	Yellow Material	Stainless Steel	-40	+180	+150	-40	+82	+66	18,000	262,690	11.61	56.67

Classic Sprockets

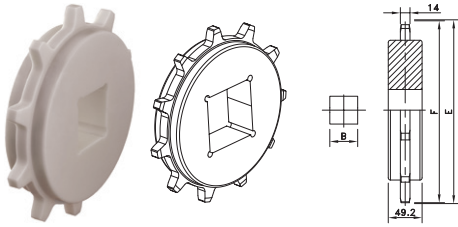

Sprocket Type	Code Number	Number of Teeth	Bore	Pitch Diameter	Outside Diameter	Hub Width
			B	E	F	A
Classic Sprocket						
Square Bore						

KU3120-9T_60MM_S_PA	10333226	9	60	222.8	218.9	47.8
KU3120-9T_90MM_S_PA	10334667	9	90			
KU3120-10T_60MM_S_PA	10333227	10	60	246.6	244.1	
KU3120-10T_90MM_S_PA	10334668	10	90			
KU3120-11T_60MM_S_PA	10333228	11	60	270.5	269.1	
KU3120-11T_90MM_S_PA	10334669	11	90			

Split Sprockets

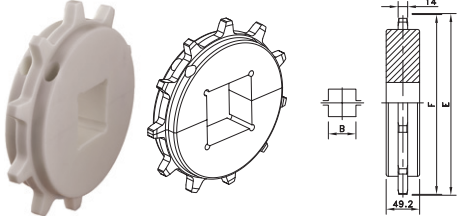

Split Sprockets

Square Bore						
KUS3120-9T_60MM_S_PA	10333329	9	60	222.8	218.9	47.8
KUS3120-9T_90MM_S_PA	10334701	9	90			
KUS3120-10T_60MM_S_PA	10333330	10	60	246.6	244.1	
KUS3120-10T_90MM_S_PA	10334702	10	90			
KUS3120-11T_60MM_S_PA	10333331	11	60	270.5	269.1	
KUS3120-11T_90MM_S_PA	10334703	11	90			

H-Style 3180 Sprockets

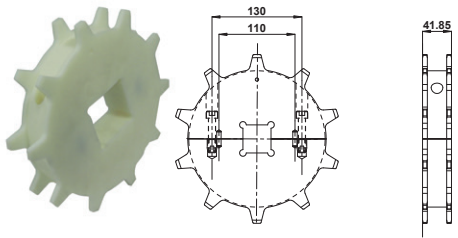

H-Style 3180 Sprockets

Square Bore						
KU3180-8T_60MM_S_PA_H	10328857	8	60	199	193.5	42
KU3180-9T_60MM_S_PA_H	10328851	9	90	223	218.9	
KU3180-10T_60MM_S_PA_H	10328845	10	60	246	244.1	
KU3180-11T_60MM_S_PA_H	10328839	11	90	270	269.1	

H-Style 3120 Sprockets

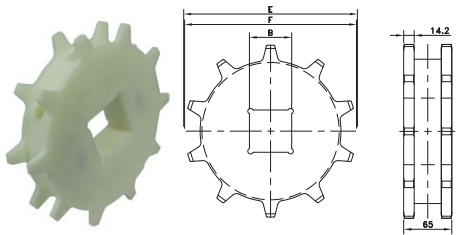

H-Style 3120 Sprocket

Square Bore						
KU3120-8T_60MM_S_PA_H-HUB	10334885	8	60	199.1	193.5	65
KU3120-9T_60MM_S_PA_H-HUB	10363526	9	60	222.8	218.9	
KU3120-10T_60MM_S_PA_H-HUB	10383669	10	60	246.6	244.1	
KU3120-11T_60MM_S_PA_H-HUB	10328782	11	60	270.5	269.1	

Other bores sizes (square and round) and number of teeth are available on request. Smallest possible sprocket has 8 teeth. Stainless steel sprockets available upon request.



Din style sideguard 3120

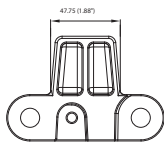

H40 dimensions

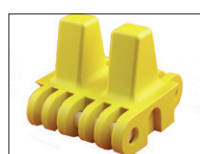
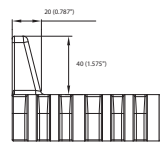

Din style pusher 3120

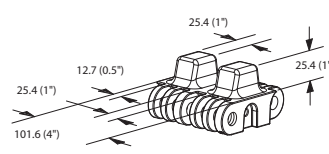

T1 dimensions

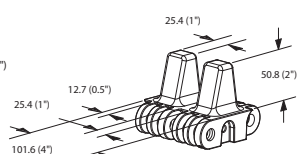

T2 dimensions



La gamma di nastri curvilinei è disponibile nella versione 505 con passo da ½ pollice, nella versione 1200 con passo da 1¼ di pollice e nella versione 7956 con passo da 1¼ pollice, con una soluzione per praticamente qualsiasi applicazione curva. Di serie, i nastri vengono forniti in acetilica a basso attrito per le bevande, in acetilica o polipropilene.

Caratteristiche

• Conformemente agli standard del settore, vengono offerti tre sistemi di curvatura:

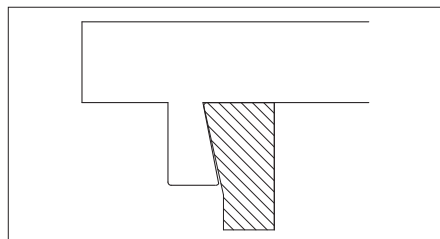

Il sistema RBP utilizza guide Positrack smussate sotto al nastro per guidarlo nella curva. Le anse scorrono contro un profilo smussato, mantenendo il nastro nella curva. Questo sistema consente l'agevole rimozione del nastro dal trasportatore per le operazioni di pulizia o manutenzione. Il prodotto trasportato può essere più ampio del nastro, in quanto sopra al nastro non è presente nessuna guida di scorrimento che lo trattenga verso il basso.

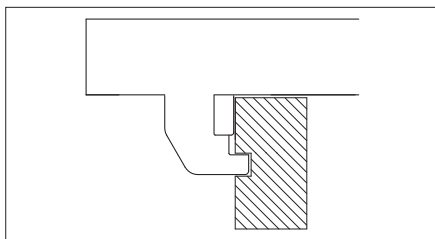

Il sistema di guida RBT utilizza delle guide TAB al di sotto del nastro, che consentono di tenerlo abbassato mentre scorre attraverso la curva. Spesso le guide TAB possono essere utilizzate per agganciare il nastro nella parte di ritorno del trasportatore. A seconda della struttura, le catene MatTop con guide TAB sono più difficili da rimuovere dal trasportatore per le operazioni di pulizia e manutenzione.

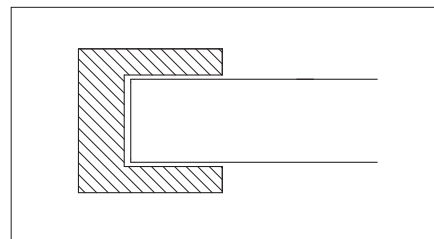

Il sistema RB (nastro piatto senza TAB e Positrack) è adatto per i tradizionali metodi di guida a sostegno del nastro sul suo raggio interno. Il nastro viene tenuto abbassato nella curva mediante una guida di scorrimento nella parte superiore del nastro oppure mediante scorrimento attraverso un canale a U. Questo metodo può essere applicato anche nella parte di ritorno. In questo modo è difficile rimuovere il nastro dal trasportatore. Le versioni RB sono adatte per le applicazioni a spirale a bassa tensione.

• I materiali dei nastri e delle guide curve hanno un limite PV (Pressione/Velocità) che determina la velocità o il carico massimo in un'applicazione specifica. Il software per i calcoli e i manuali tecnici Rexnord informeranno l'utente in merito alla fattibilità di un'applicazione specifica. Per le applicazioni a spirale, si consiglia di rivolgersi a un rivenditore qualificato, per evitare problemi di sovraccarico e guasti.

Programma	
505-Series	Per i piccoli prodotti impacchettati e gli alimenti sfusi; combina un raggio interno ridotto con trasferimenti in linea minimi e un'area aperta del 10%; disponibili in RBP e RB
1200-Series	Per l'industria alimentare, delle bevande, degli imballaggi e altri settori. Combina un'area aperta al 39% e la struttura che consente un'agevole pulizia con una superficie ottimizzata per il supporto del prodotto. Sono disponibili vari tipi: <ul style="list-style-type: none"> • Versione standard 1255; disponibile in RBP e RB; RBT su richiesta • 1255 SuperGrip con gomma per applicazioni inclinate e in discesa; disponibile RBP e RB • Il 1265 combina moduli interni 1255 con moduli esterni appositamente studiati muniti di TAB e blocchi di scorrimento speciali per carichi ingombranti, possibilità di alta velocità; disponibile in RBT sul raggio esterno, il raggio interno può essere munito di RBP, RBT e RB • Il 1275 combina moduli esterni 1255 standard con moduli interni appositamente studiati, creando una struttura a raggio compatto con rapporto 1.2 rispetto alla larghezza; disponibile in RBP, RBT e RB • Il 1285 combina il modulo esterno 1265 e il modulo interno 1275 per un'elevata resistenza, alta velocità e struttura compatta. Sistema di guida RBT sul raggio esterno; il raggio interno può essere munito di RBP, RBT e RB
7956-Series	Per i prodotti di grandi dimensioni e pesanti nel settore alimentare di bevande e per applicazioni di trasporto casse; il raggio interno minimo è pari a 2 volte la larghezza del nastro e la superficie ad area aperta del 16% offre il massimo supporto dei prodotti; la catena ha la stessa resistenza sia in rettilineo che in curva. Molte esecuzioni disponibili: <ul style="list-style-type: none"> • 7956 NT bordo liscio senza tabs • 7956 TAB con TAB di ritenzione • 7956 GT con TAB ad alte prestazioni di dimensioni simile alla versione con cuscinetti • 7956 B con cuscinetti a sfere ogni due passi per applicazioni ad alta velocità e carichi molto elevati
Accessori per i nastri	Facchini sul modello 1255 per applicazioni inclinate o in discesa nell'industria alimentare

Panoramica prodotti delle Serie 1285

Il design delle Serie 1285 comprende due versioni:

- Le versioni 1285 /B sono progettate appositamente per le guide angolari lavorate
- Le versioni 1285 /G sono progettate appositamente per le curve dotate di cuscinetto a sfera

Serie 1285 in curve lavorate

Le catene delle Serie 1285, adatte per le curve lavorate, sono riconoscibili da un blocchetto di riscontro di colore marrone inserito nell'aletta di guida.

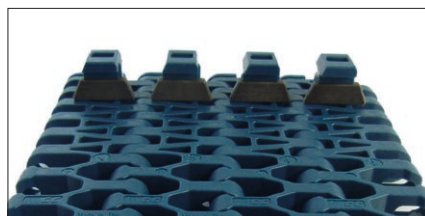

1265/1285/B

Serie 1285 in curve con cuscinetti a sfera

Le catene delle Serie 1285, adatte per le curve con cuscinetti a sfera, sono riconoscibili da un blocchetto di riscontro di colore grigio inserito nell'aletta di guida.

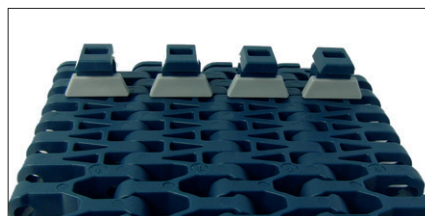

1265/1285/G

Radius 505

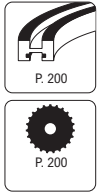
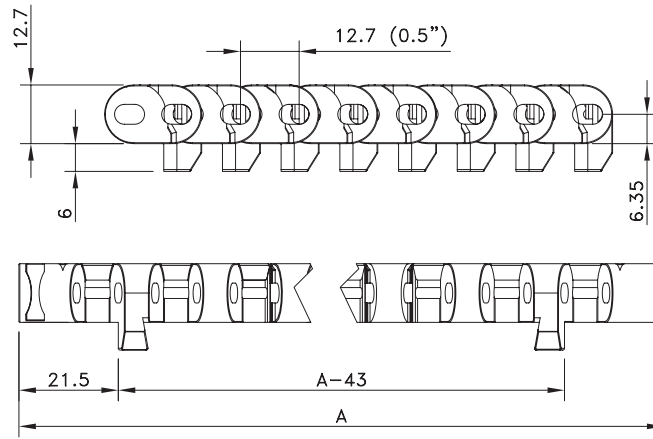
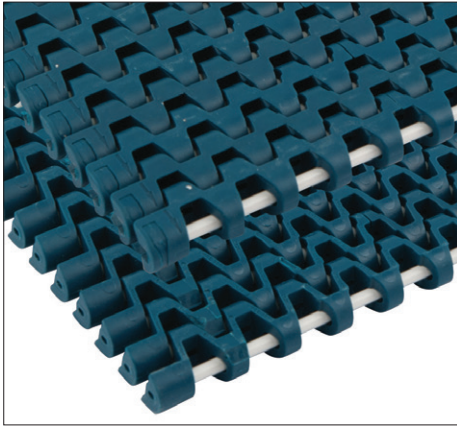

Assembly	Belt Type	Code Number*	Width A	Sideflex radius inside (min.)	Working Load (max.)		Temperature range °C		Weight	Backflex Radius (min.)
					Straight	in curve	Dry	Wet		
					N/m	N				
XLG-Acetal With Reinforced Plastic Pins										
	RBP 505 XLG 255	867.30.12	255	510	15000	1300	-40 TO +80	-40 TO +65	10.0	15
	RBP 505 XLG 340	867.30.13	340	680						
	RBP 505 XLG 425	867.30.14	425	850						
	RBP 505 XLG 510	867.30.15	510	1020						
	RBP 505 XLG 595	867.30.16	595	1190						
	RBP 505 XLG 680	867.30.17	680	1360						
WSM-Acetal With Reinforced Plastic Pins										
Positrack	WSM 505 RBP	868.30.xx	255 to 680	x belt width	15000	1300	-40 TO +80	-40 TO +65	10.0	15
SMB-Acetal With Reinforced Plastic Pins										
Positrack	SMB 505 RBP	868.50.xx	255 to 680	x belt	15000	1300	-40 TO +80	-40 TO +65	10.0	15

* In code numbers xx corresponds with the belt width (A), starting with 12 for 255 mm, 13 for 340 mm and so on with 85 mm increments up to 680 mm; wider belts available upon request. See also page 208.

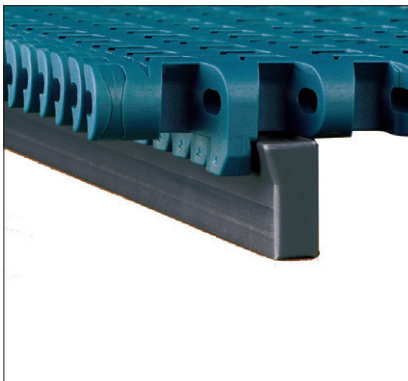

Curve guiding profile for 505

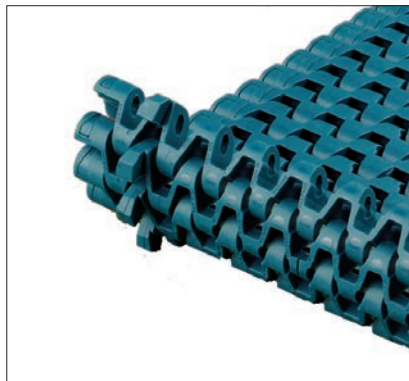

Standard positrack lugs on both sides

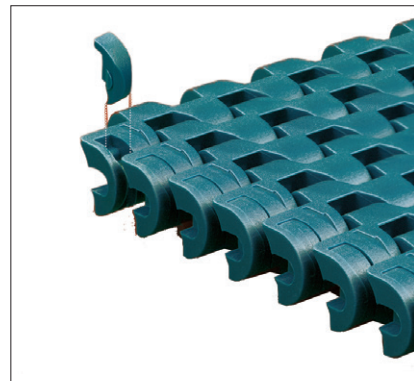

Pin retention clips for easy (dis)assembly

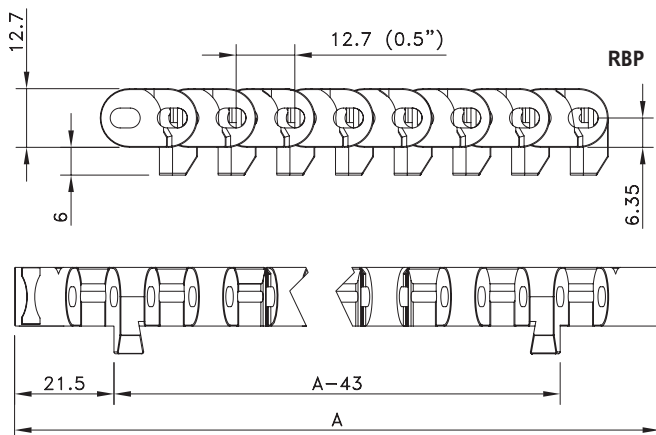

The curve guiding profile for the 505 has a standard length of 1.8 meters; it is made of MCC 3500 special polyamide, code nr. 800.00.01, or MCC 3600 polyester for direct food contact, code nr. 800.00.13, ULF-profile: 10383606

Split Sprockets Machined

Split Sprockets Injection Moulded

Classic Sprockets

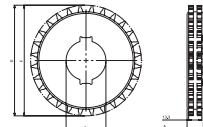
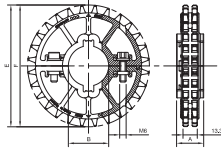
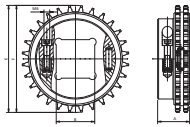

Sprocket Type	Code Number	Number of Teeth	Bore	Pitch Diameter	Outside Diameter	Hub Width
			B mm/inch	E mm	F mm	A mm

Split Sprockets Machined

Round Bores

KUS505-28T_25MM_2KW_PA	10331058	28	25 mm	113.4	113.4	33.5
KUS505-28T_30MM_2KW_PA	10331458	28	30 mm			
KUS505-28T_35MM_2KW_PA	10331811	28	35 mm			
KUS505-28T_1IN_2KW_PA	10326599	28	1.0"			

Square Bores

KUS505-28T_25MM_S_PA	10331057	28	25 mm	113.4	113.4	33.5
KUS505-28T_30MM_S_PA	10331457	28	30 mm			
KUS505-28T_1IN_S_PA	10326598	28	1.0"			

Split Sprockets Injection Moulded

Round Bores

NS505-28T_40MM_2KW_PA	10332337	28	40 mm	113.4	113.4	25.5
NS505-28T_1-1/2IN_1KW_PA	10328198	28	1.5"			

Square Bores

NS505-28T_40MM_S_PA	10148171	28	40 mm	113.4	113.4	25.5
NS505-28T_1-1/2IN_S_PA	10362458	28	1.5"			

Classic Sprockets

Round Bores

KU505-28T_25MM_2KW_PA	10330882	28	25 mm	113.4	113.4	16.5
KU505-28T_30MM_2KW_PA	10331285	28	30 mm			
KU505-28T_35MM_2KW_PA	10331678	28	35 mm			
KU505-28T_40MM_2KW_PA	10332008	28	40 mm			
KU505-28T_1IN_2KW_PA	10325158	28	1.0"			
KU505-28T_1-1/2IN_2KW_PA	10325583	28	1.5"			

Square Bores

KU505-28T_25MM_S_PA	10330883	28	25 mm	113.4	113.4	16.5
KU505-28T_30MM_S_PA	10331286	28	30 mm			
KU505-28T_40MM_S_PA	10148125	28	40 mm			
KU505-28T_1IN_S_PA	10325159	28	1.0"			
KU505-28T_1-1/2IN_S_PA	10325584	28	1.5"			

Positrack Curves

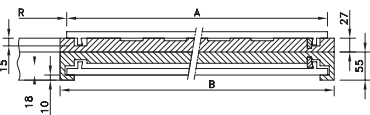

Code Number	Radius R mm	Belt Width A mm	Height mm	Curve Width B mm	Angle
-------------	----------------	--------------------	--------------	---------------------	-------

Positrack Curves

For 505

804.02.02	510	255	27 + 55	281	90°
804.02.03	680	340	27 + 55	366	
804.02.04	850	425	27 + 55	451	
804.02.05	1020	510	27 + 55	536	
804.02.06	1190	595	27 + 55	621	
804.02.07	1360	680	27 + 55	706	

Other angles and non-standard positrack curves on request; these curves include a curve guiding profile. Including 100 mm long straight sections at upper part.

Radius 1255

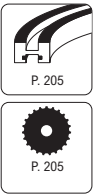
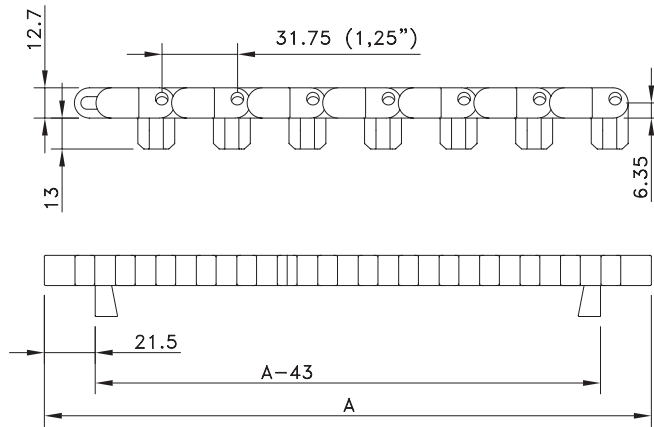
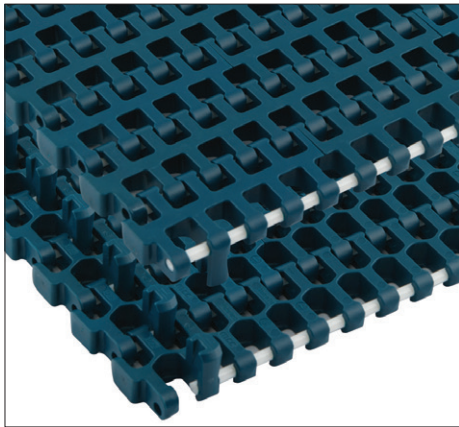

Assembly	Belt Type	Code Number*	Sideflex Radius (min.)	Temperature range °C		Working Load (max.)		Weight	Backflex Radius (min.)
				mm	Dry	Wet	Straight		
XLG-Acetal with PBT Pins									
Positrack Two Sides	RBP 1255 XLG	867.40.xx	2 x belt width	-40 to +80	-40 to +65	22000	2000	8.00	25
Flat	RB 1255 XLG	867.70.xx		-40 to +65					
Supergrip Positrack	SG 1255 XLG RBP	867.53.xx		-40 to +65					
WHT-Polypropylene with PBT Pins									
Positrack Two Sides	WHT 1255 RBP	869.40.xx	2 x belt width	4 to 80	4 to 65	11000	1200	5.20	25
Flat	WHT 1255 RB	869.90.xx		4 to 65					
Supergrip Positrack	SG 1255 WHT RBP	869.53.xx		4 to 65					
BHT-Polypropylene with PBT Pins									
Flat	BHT 1255 RB	869.80.xx	2x belt width	4 to 65	4 to 80	11000	1200	5.20	25
WSM-Acetal with PBT Pins									
Positrack Two Sides	WSM 1255 RBP	868.40.xx	2x belt width	-40 to +80	up to 65	22000	2000	8.00	25
Flat	WSM 1255 RB	869.00.xx		-40 to +65					
Supergrip Positrack	SG 1255 WSM RBP	868.63.xx		-40 to +65					
SMB-Acetal with PBT Pins									
Flat	SMB 1255 RB	869.10.xx	2x belt width	-40 to +80	up to 65	22000	2000	8.00	25

* In code numbers xx corresponds with the belt width (A), starting with 12 for 255 mm, 13 for 340 mm.

If you need flights, describe the belt by choosing from the required options listed in the 2nd column of the table:

Material	WHT or BHT or WSM or SMB	
Belt type	1255 RBP or 1255 RBT or 1255 RB	RBP for Positrack (only in WHT, WSM and SMB), RBT for Tabs (only in WSM and SMB), RB for Flat
Width (A)	KM - in mm	
Flights	F3	Standard height of 3" (76.2 mm) or special height in mm
Pitch between flights	T..P	Flights on every ..th row
Flight side-indent	N.. (in mm)	Minimal 51 mm with 17 mm increments

code nr. for special polyamide MCC3500 profile of 1.8 meters is 10609192, code for FDA approved MCC3600 polyester profile of 1.8 meters is 10361335.

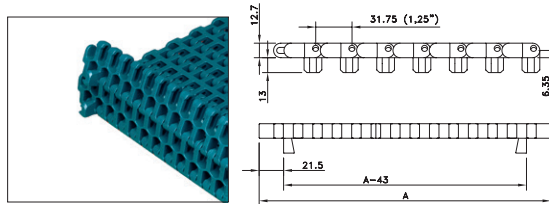

Positrack lugs on both sides

RBP

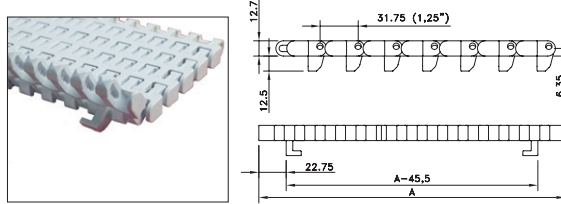

Tabs on both sides

RBT

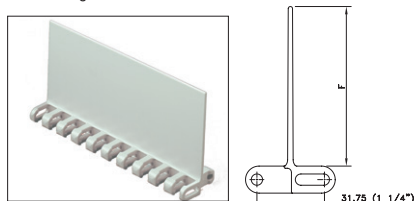

Flight for elevating Not for use in the U.S.A.

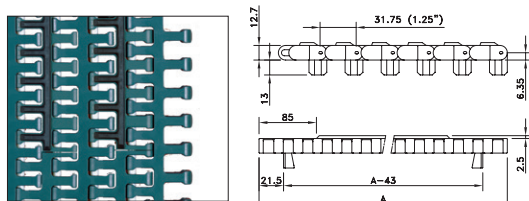

Supergrip for inclined conveying: Standard 100% rubber.

RBP

Radius 1265 Reinforced outer Modules

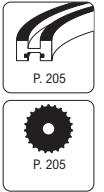
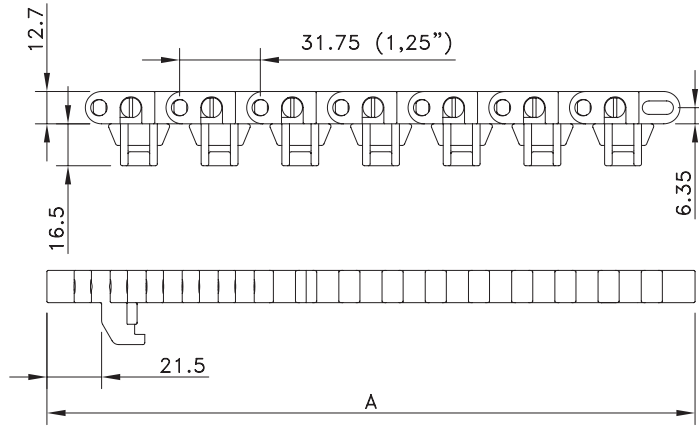
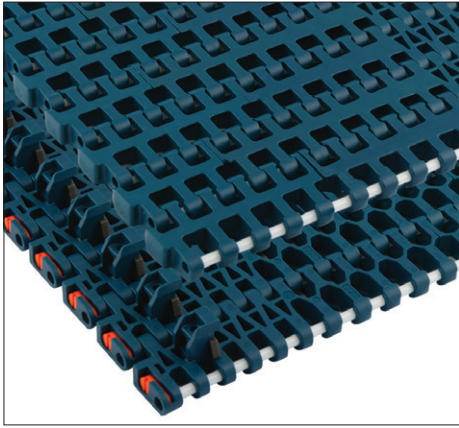

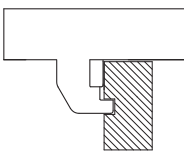
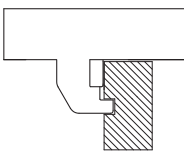
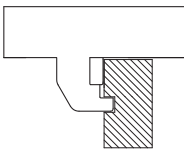
Assembly	Belt Type	Code Number*	Width A	Sideflex Radius (min)	Temperature range °C		Working Load (max.)		Weight	Backflex Radius (min.)
					Dry	Wet	Straight	In Curve		
			mm	mm			N/m (21°C)	N	kg/m ²	mm
XLG-Acetal with PBT Pins										
Tabs/Flat 	RBT 1265 RB XLG/B 255	864.60.12	255	510	-40 to 80	-40 to +65	22000	3000	8.00	25
	RBT 1265 RB XLG/B 340	864.60.13	340	680						
	RBT 1265 RB XLG/B 425	864.60.14	425	850						
	RBT 1265 RB XLG/B 510	864.60.15	510	1020						
	RBT 1265 RB XLG/B 595	864.60.16	595	1190						
	RBT 1265 RB XLG/B 680	864.60.17	680	1360						
	RBT 1265 RB XLG/B 765	864.60.18	765	1530						
	RBT 1265 RB XLG/B 850	864.60.19	850	1700						
	RBT 1265 RB XLG/B 935	864.60.20	935	1870						
	RBT 1265 RB XLG/B 1020	864.60.21	1020	2040						
Tabs/Positrack 	RBT 1265 RBP XLG/B255	864.00.12	255	510	-40 to +80	-40 to +65	22000	3000	8.00	25
	RBT 1265 RBP XLG/B340	864.00.13	340	680						
	RBT 1265 RBP XLG/B425	864.00.14	425	850						
	RBT 1265 RBP XLG/B510	864.00.15	510	1020						
	RBT 1265 RBP XLG/B595	864.00.16	595	1190						
	RBT 1265 RBP XLG/B680	864.00.17	680	1360						
	RBT 1265 RBP XLG/B765	864.00.18	765	1530						
	RBT 1265 RBP XLG/B850	864.00.19	850	1700						
	RBT 1265 RBP XLG/B935	864.00.20	935	1870						
	RBT 1265 RBP XLG/B1020	864.00.21	1020	2040						
WSM-Acetal with PBT Pins										
Tabs/Flat 	WSM/B 1265 RBT RB 255	864.90.12	255	510	-40 to +80	-40 to +65	22000	3000	8.00	25
	WSM/B 1265 RBT RB 340	864.90.13	340	680						
	WSM/B 1265 RBT RB 425	864.90.14	425	850						
	WSM/B 1265 RBT RB 510	864.90.15	510	1020						
	WSM/B 1265 RBT RB 595	864.90.16	595	1190						
	WSM/B 1265 RBT RB 680	864.90.17	680	1360						
	WSM/B 1265 RBT RB 765	864.90.18	765	1530						
	WSM/B 1265 RBT RB 850	864.90.19	850	1700						
	WSM/B 1265 RBT RB 935	864.90.20	935	1870						
	WSM/B 1265 RBT RB 1020	864.90.21	1020	2040						

Other widths (17 mm increments from standard) available upon request.

Code nr. for special polyamide profile of 1.8 meters is ULF-Profile 10383623.

Radius 1275 Tight Radius Inner Modules

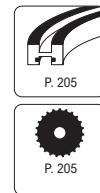
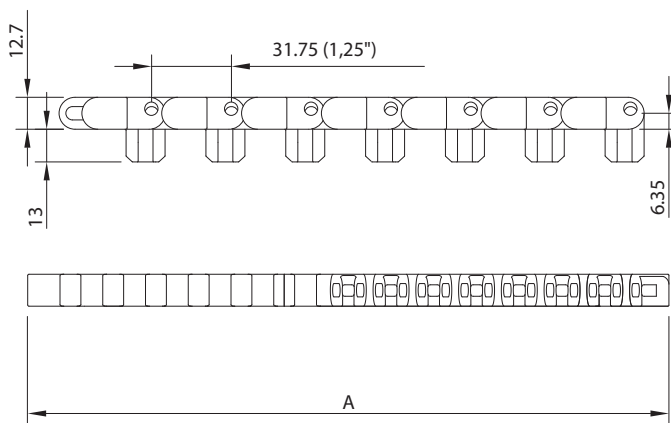
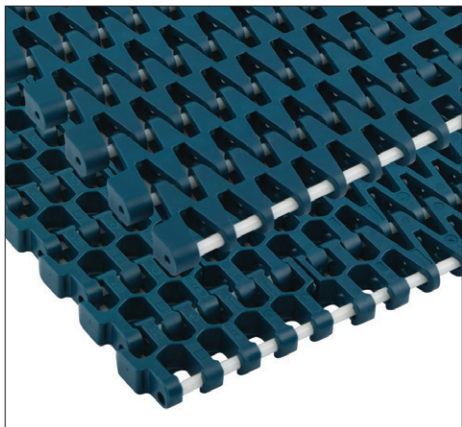

Assembly	Belt Type	Code Number*	Width A	Sideflex Radius (min)	Temperature range °C		Working Load (max.)		Weight	Backflex Radius (min.)
					Dry	Wet	Straight	In Curve		
			mm	mm			N/m (21°C)	N	kg/m ²	mm
XLG-Acetal with PBT Pins										
	XLG 1275 RB-RB 255	860.90.12	255	300	-40 to +80	-40 to +65	22000	2000	8.00	25
	XLG 1275 RB-RB 340	860.90.13	340	400						
	XLG 1275 RB-RB 425	860.90.14	425	500						
	XLG 1275 RB-RB 510	860.90.15	510	600						
	XLG 1275 RB-RB 595	860.90.16	595	720						
	XLG 1275 RB-RB 680	860.90.17	680	880						
	XLG 1275 RB-RB 765	860.90.18	765	1040						
XLG-Acetal with PBT Pins										
	XLG 1275 RBP-RB 255	864.70.12	255	300	-40 to +80	-40 to +65	22000	2000	8.00	25
	XLG 1275 RBP-RB 340	864.70.13	340	400						
	XLG 1275 RBP-RB 425	864.70.14	425	500						
	XLG 1275 RBP-RB 510	864.70.15	510	600						
	XLG 1275 RBP-RB 595	864.70.16	595	720						
	XLG 1275 RBP-RB 680	864.70.17	680	880						
	XLG 1275 RBP-RB 765	864.70.18	765	1040						
XLG-Acetal with PBT Pins										
	XLG 1275 RBT-RB 255	876.11.36	255	300	-40 to +80	-40 to +65	22000	2000	8.00	25
	XLG 1275 RBT-RB 340	876.15.31	340	400						
	XLG 1275 RBT-RB 425	876.13.59	425	500						
	XLG 1275 RBT-RB 510	876.20.20	510	600						
	XLG 1275 RBT-RB 595	876.38.49	595	720						
	XLG 1275 RBT-RB 680	876.17.92	680	880						
	XLG 1275 RBT-RB 765	876.38.50	765	1040						

Other widths (17 mm increments from standard) and materials available upon request.

Code for RBT profile: 10383613
Code for RBP profile: 10383610

Not for use in the U.S.A.

Radius 1285 Reinforced Outer and Tight Fit Inner Modules

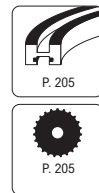
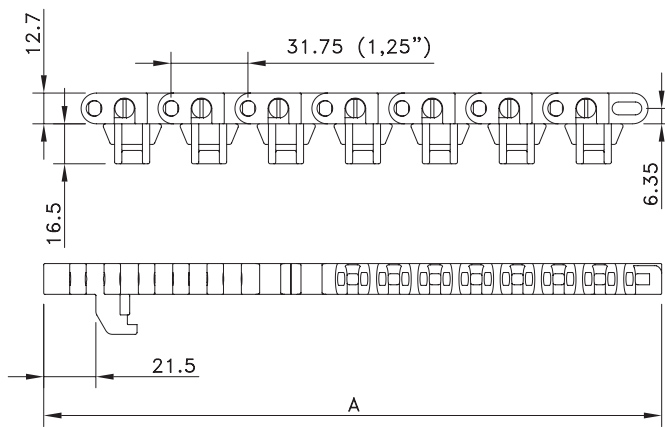

Assembly	Belt Type	Code Number*	Width A	Sideflex Radius (min)	Temperature range °C		Working Load (max.)		Weight	Backflex Radius (min.)
					Dry	Wet	Straight	In Curve		
			mm	mm			N/m (21°C)	N	kg/m ²	mm
XLG-Acetal with PBT Pins										
	RBT 1285 RB XLG/B 425	863.60.14	425	500	-40 to +80	-40 to +65	22000	3000	8.00	25
	RBT 1285 RB XLG/B 510	863.60.15	510	600						
	RBT 1285 RB XLG/B 595	863.60.16	595	720						
	RBT 1285 RB XLG/B 680	863.60.17	680	880						
	RBT 1285 RB XLG/B 765	863.60.18	765	1040						
	RBT 1285 RB XLG/B 850	863.60.19	850	1200						
	RBT 1285 RB XLG/B 935	863.60.20	935	1350						
	RBT 1285 RB XLG/B 1020	863.60.21	1020	1500						
WSM-Acetal with PBT Pins										
	WSM/B 1285 RBT RB 425	865.10.14	425	500	-40 to +80	-40 to +65	22000	3000	8.00	25
	WSM/B 1285 RBT RB 510	865.10.15	510	600						
	WSM/B 1285 RBT RB 595	865.10.16	595	720						
	WSM/B 1285 RBT RB 680	865.10.17	680	880						
	WSM/B 1285 RBT RB 765	865.10.18	765	1040						
	WSM/B 1285 RBT RB 850	865.10.19	850	1200						
	WSM/B 1285 RBT RB 935	865.10.20	935	1350						
	WSM/B 1285 RBT RB 1020	865.10.21	1020	1500						

Other widths (17 mm increments from standard) available upon request. Code nr. for special polyamide profile of 1.8 meters is ULF-Profile 10383623.

For 1285 belts with Positrack, please contact Customer Service.

Curves

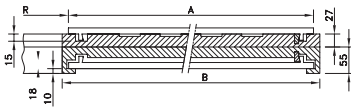

These curves include a curve guiding profile. Including 100 mm long straight sections at upper part. Other angles and non-standard tab curves on request.

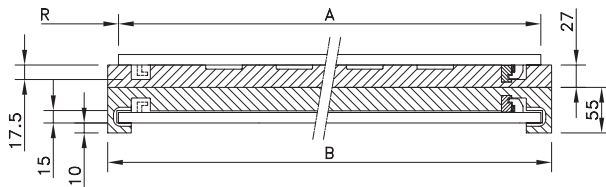

Code Number	Radius	Belt Width	Curve Width	Height	Angle
	R	A	B	mm	

Curves

For 1255 RBP

805.02.02	510	255	281	27 + 55	90°
805.02.03	680	340	366		
805.02.04	850	425	451		
805.02.05	1020	510	536		
805.02.06	1190	595	621		
805.02.07	1360	680	706		

For 1275 RBP

805.22.61	300	255	281	27+55	90°
805.22.62	400	340	366		
805.22.63	500	425	451		
805.22.64	600	510	536		
805.22.65	720	595	621		
805.22.66	880	680	706		

For 1265 RBT

806.40.13	510	255	281	27+55	90°
806.40.14	680	340	366		
806.40.15	850	425	451		
806.40.16	1020	510	536		
806.40.17	1190	595	621		
806.40.18	1360	680	706		

For 1285 RBT

806.40.19	500	425	451	27+55	90°
806.40.20	600	510	536		
806.40.21	720	595	621		
806.40.22	880	680	706		

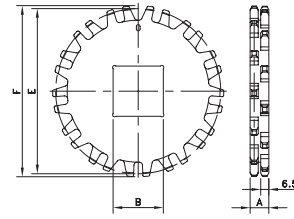
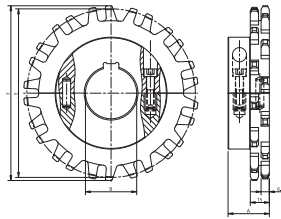

Sprocket Type	Code Number	Number of Teeth	Bore	Pitch Diameter	Outside Diameter	Hub Width
			B	E	F	A
			mm/inch	mm	mm	mm

Split Sprockets

Round Bores

KUS1200-10T_30MM_1KW_PA	10331532	10	30	102.8	106.6	32.5
KUS1200-13T_40MM_1KW_PA	10332246	13	40	132.7	137.5	
KUS1200-15T_40MM_1KW_PA	10362432	15	40	152.7	158.1	
KUS1200-16T_40MM_1KW_PA	10332249	16	40	162.8	168.3	

Square Bores

KUS1200-10T_30MM_S_PA	10331531	10	30	102.8	106.6	32.5
KUS1200-13T_40MM_S_PA	10332245	13	40	132.7	137.5	
KUS1200-15T_40MM_S_PA	10332248	15	40	152.7	158.1	
KUS1200-16T_40MM_S_PA	10362435	16	40	162.8	168.3	

Classic Sprockets

Round Bores

KU1200-8T_30MM_1KW_PA	10331344	8*	30	83.0	85.4	15.0
KU1200-10T_30MM_1KW_PA	10331347	10	30	102.8	106.6	
KU1200-13T_40MM_1KW_PA	10332071	13	40	132.7	137.5	
KU1200-15T_40MM_1KW_PA	10332074	15	40	152.7	158.1	
KU1200-16T_40MM_1KW_PA	10332077	16	40	162.8	168.3	

Square Bores

KU1200-8T_25MM_S_PA	10330943	8*	25	83.0	85.4	15.0
KU1200-10T_40MM_S_PA	10332070	10	40	102.8	106.6	
KU1200-13T_40MM_S_PA	10332073	13	40	132.7	137.5	
KU1200-15T_40MM_S_PA	10332076	15	40	152.7	158.1	
KU1200-16T_40MM_S_PA	10332079	16	40	162.8	168.3	

* 8-teeth sprockets are not applicable for 1265 and 1285.

Radius 7956

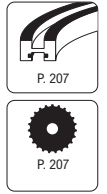
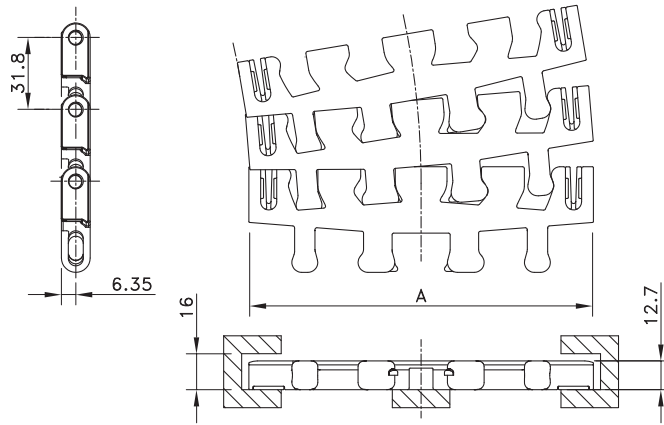
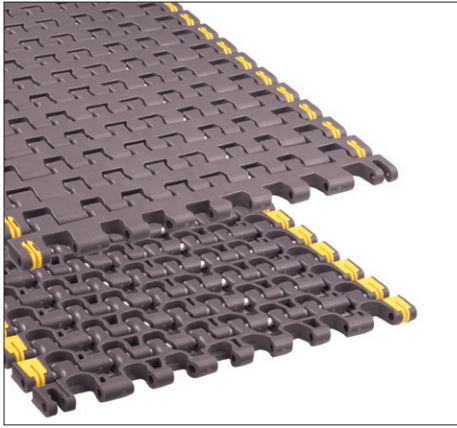

Assembly	Belt Type	Code Number*	Width A	Sideflex Radius (min)	Temperature range °C		Working Load (max.)		Weight	Backflex Radius (min.)	
					Dry	Wet	Straight	In Curve			
			inch	inch	N/m (21°C)	N	kg/m ²	mm			
HP-Acetal with Polypropylene Pins											
Flat	HP 7956 NT-K6	81417101	6	12	2000	2000	-40 to + 80	-40 to +65	11.7	152	
	HP 7956 NT-K12	81429711	12	24	3560	3560					
	HP 7956 NT-K15	81427901	15	30	4000	4000					
	HP 7956 NT-K18	81427911	18	36	4225	4225					
	HP 7956 NT-K24	81428241	24	48	5300	5300					
	HP 7956 NT-K30	81428631	30	60	5780	5780					
Tabs Two Sides (Hold-Down)	HP 7956 TAB-K6	81417091	6	12	2000	2000	-40 to + 80	-40 to +65	11.7	152	
	HP 7956 TAB-K12	81429671	12	24	3560	3560					
	HP 7956 TAB-K15	81415631	15	30	4000	4000					
	HP 7956 TAB-K18	81421801	18	36	4225	4225					
	HP 7956 TAB-K24	81419711	24	48	5300	5300					
	HP 7956 TAB-K30	81427261	30	60	5780	5780					
Tabs Two Sides (GT)	HP7956 GT-K6	81436441	6	12	2000	2000	-40 to + 80	-40 to +65	11.7	152	
	HP7956 GT-K12	81436471	12	24	3560	3560					
	HP7956 GT-K15	81436501	15	30	4000	4000					
	HP7956 GT-K18	81436531	18	36	4225	4225					
	HP7956 GT-K24	81436561	24	48	5300	5300					
	HP7956 GT-K30	81436591	30	60	5780	5780					
Bearing (Every 2 nd Row)	HP7956 B-K6	CCW	81437471	6	12	2000	2000	-40 to + 80	-40 to +65	11.7	152
		CW	81437461								
		STURN	81437481								
	HP7956 B-K12	CCW	81437491	12	24	3560	3560				
		CW	81433641								
		STURN	81437501								
	HP7956 B-K15	CCW	81437521	15	30	4000	4000				
		CW	81437511								
		STURN	81437531								
	HP7956 B-K18	CCW	81433441	18	36	4225	4225				
		CW	81433691								
		STURN	81437541								
	HP7956 B-K24	CCW	81433611	24	48	5300	5300				
		CW	81437551								
		STURN	81437561								
	HP7956 B-K30	CCW	81437581	30	60	5780	5780				
		CW	81437571								
		STURN	81437591								

Curves

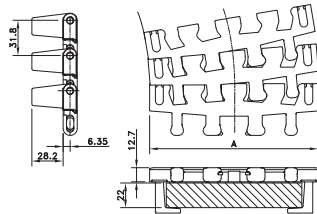
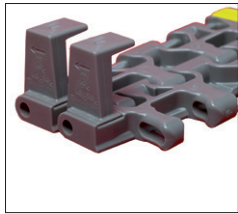

Hold-Down Tabs

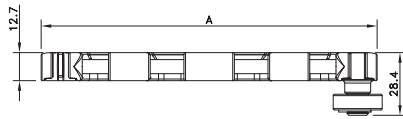
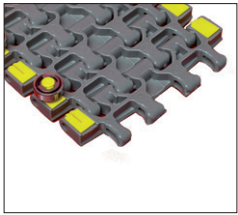

Bearings

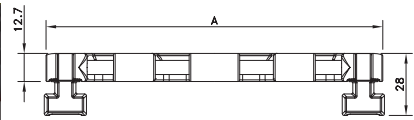
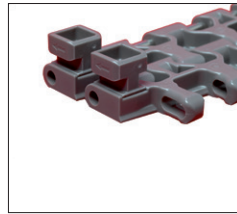

GT Tabs

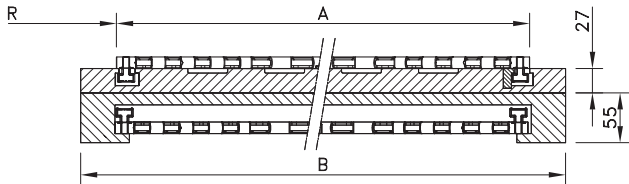

Curves for 7956 GT include a special curve guiding profile. Other angles and non-standard tab curves on request.

Code Number	Radius R	Belt Width A	Curve Width B	Height	Angle
	mm	mm	mm	mm	

Curves

For 7956 B

808.40.00	305	6	196	27+55	90°
808.40.01	610	12	366		
808.40.02	762	15	451		
808.40.03	915	18	536		
808.40.04	1220	24	706		
808.40.05	1524	30	791		

For 7956 GT

808.40.06	305	6	196	27+55	90°
808.40.07	610	12	366		
808.40.08	762	15	451		
808.40.09	915	18	536		
808.40.10	1220	24	706		
808.40.11	1524	30	791		

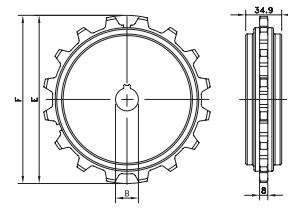
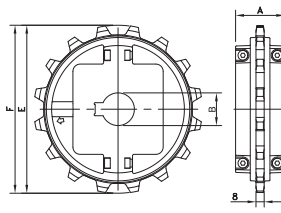

Sprocket Type	Code Number	Number of Teeth	Bore	Pitch Diameter	Outside Diameter	Hub Width
			B	E	F	A
			mm/inch	mm	mm	mm

Split Sprockets

Round Bores

NS7956-16T_25MM_1KW_PA	10334114	16	25	162.7	163.2	48
NS7956-16T_30MM_1KW_PA	10019770	16	30			
NS7956-16T_35MM_1KW_PA	10334116	16	35			
NS7956-16T_40MM_1KW_PA	10334117	16	40			

Square Bores

NS7956-16T_40MM_S_PA	10333885	16	40	162.7	163.2	48
NS7956-16T_50MM_S_PA	10333886	16	50			
NS7956-16T_60MM_S_PA	10333887	16	60			

Classic Sprockets

Round Bores

KU7956-14T_30MM_1KW_PA_SP	10331431	14	40	142.7	142.4	35
KU7956-14T_40MM_1KW_PA_SP	10332146	14	40			

KU 7956 T14 R40 Square Bores

KU7956-14T_40MM_S_PA_SP	10332148	14	40	142.7	142.4	35
-------------------------	----------	----	----	-------	-------	----

Belt Series	Standard (uncut)		Non-standard (cut)		MTW
	Minimum Belt Width	Belt width Increments	Minimum Belt Width	Belt width Increments	Moulded to Width Belts
500	85 mm	85 mm	85 mm	on request	-
515	4"	1"	2"	½"	-
1505 imperial	3"	3"	4½"	¾"	-
1505 metric	85 mm	85 mm	85 mm	on request	-
1506	3"	3"	4½"	¾"	-
1505 SG	85 mm	85 mm	85 mm	on request	-
8500	6"	6"	2½"	½"	2½" - 3¼" - 4½" - 7½" - 85 mm
5935	6"	3"	3"	¾"	-
5936	6"	3"	2¼"	¾"	-
1000	85 mm	85 mm	55 mm	5 mm	-
1000 SG	85 mm	85 mm	80 mm	10 mm	-
1015	4"	1"	4"	½" **	-
1005	85 mm	85 mm	85 mm	17 mm	-
1005 SG	170 mm	85 mm	85 mm	17 mm	-
7705	6"	3"	5"	½"	3¼" - 4½" - 7½"
7706	6"	3"	5"	½"	3¼" - 4½" - 7½"
7708	9"	3"	5"	½"	-
6300	255 mm	75 mm	225 mm	on request	-
2000	3"	3"	3"	1½"	-
2010	6"	2"	3⅓"	⅔"	-
6990	9"	3"	5"	½"	-
1800	6"	3"	4,67"	0,33"	3"(1805)
9200	9"	3"	-	-	-
2500	18"	3"	3"	1½"	-
3125	-	-	-	-	12"
505	255 mm	85 mm	153 mm	17 mm	-
1255	255 mm	85 mm	153 mm	17 mm	-
1255 SG	255 mm	85 mm	153 mm	17 mm	-
1265	255 mm	85 mm	255 mm	17 mm	-
1275	255 mm	85 mm	237 mm	17 mm	-
1285	425 mm	85 mm	357 mm	17 mm	-
7956	-	-	-	-	6" - 12" - 15" - 18" - 24" - 30"
390	6 inch - 152.4mm	2 inch - 50.8mm	6 inch - 152.4mm	2 inch - 50.8mm	-
590	4 inch - 101.6mm	0.5 inch - 12.7mm	4 inch - 101.6mm	0.5 inch - 12.7	-
1090	4 inch - 101.6mm	0.5 inch - 12.7mm	4 inch - 101.6mm	0.5 inch - 12.7	-
6990 HYB	12 inch - 305mm	3 inch - 76.2mm	12 inch - 305mm	3 inch - 76.2mm	-
3122HYB (MTW)	4 inch - 101.6mm	-	-	-	4 inch - 101.6mm
3125HYB (MTW)	4 inch - 101.6mm	-	-	-	4 inch - 101.6mm
3120HYB	12 inch - 305mm	4 inch - 101.6mm	8 inch - 203.2mm	4 inch - 101.6mm	-

*) after 12" belt width increments are 1" - **) after 24" belt width increments are 1" - ***) smaller sizes on request

Code nr. Ending on	Width mm	Code nr. Ending on	Width mm	Code nr. Ending on	Width mm	Code nr. Ending on	Width mm	Code nr. Ending on	Width mm	Code nr. Ending on	Width mm	Code nr. Ending on	Width mm
-----------------------	-------------	-----------------------	-------------	-----------------------	-------------	-----------------------	-------------	-----------------------	-------------	-----------------------	-------------	-----------------------	-------------

Code Numbers for 500, 1000, 1005, 1500, 505 and 1200-Series

10	85	21	1020	32	1955	43	2890	54	3825	65	4760	76	5695
11	170	22	1105	33	2040	44	2975	55	3910	66	4845	77	5780
12	255	23	1190	34	2125	45	3060	56	3995	67	4930	78	5865
13	340	24	1275	35	2210	46	3145	57	4080	68	5015	79	5950
14	425	25	1360	36	2295	47	3230	58	4165	69	5100	80	6035
15	510	26	1445	37	2380	48	3315	59	4250	70	5185	81	6120
16	595	27	1530	38	2465	49	3400	60	4335	71	5270		
17	680	28	1615	39	2550	50	3485	61	4420	72	5355		
18	765	29	1700	40	2635	51	3570	62	4505	73	5440		
19	850	30	1785	41	2720	52	3655	63	4590	74	5525		
20	935	31	1870	42	2805	53	3740	64	4675	75	5610		

Code nr. Ending on	Width		Code nr. Ending on	Width		Code nr. Ending on	Width		Code nr. Ending on	Width		Code nr. Ending on	Width	
	mm	inch		mm	inch		mm	inch		mm	inch		mm	inch

Code Numbers for 2000- and 2500-Series

10	76	3	22	991	39	34	1905	75	46	2819	111	58	3734	147	70	4648	183	82	5563	219
11	152	6	23	1067	42	35	1981	78	47	2896	114	59	3810	150	71	4724	186	83	5639	222
12	229	9	24	1143	45	36	2057	81	48	2972	117	60	3886	153	72	4801	189	84	5715	225
13	305	12	25	1219	48	37	2134	84	49	3048	120	61	3962	156	73	4877	192	85	5791	228
14	381	15	26	1295	51	38	2210	87	50	3124	123	62	4039	159	74	4953	195	86	5867	231
15	457	18	27	1372	54	39	2286	90	51	3200	126	63	4115	162	75	5029	198	87	5944	234
16	533	21	28	1448	57	40	2362	93	52	3277	129	64	4191	165	76	5105	201	88	6020	237
17	610	24	29	1524	60	41	2438	96	53	3353	132	65	4267	168	77	5182	204	89	6096	240
18	686	27	30	1600	63	42	2515	99	54	3429	135	66	4343	171	78	5258	207			
19	762	30	31	1676	66	43	2591	102	55	3505	138	67	4420	174	79	5334	210			
20	838	33	32	1753	69	44	2667	105	56	3581	141	68	4496	177	80	5410	213			
21	914	36	33	1829	72	45	2743	108	57	3657	144	69	4572	180	81	5486	216			

Prodotto	Materiale delle catene	Materiale dei perni
Catene a tapparella in acciaio		
Serie 10	AISI 430 (1.4016) acciaio inossidabile speciale, cromo al 17%, per una maggiore resistenza alla corrosione, maggiore durata e resistenza	AISI 431 (1.4057)
Serie 60	Acciaio inossidabile speciale al cromo-nickel per ottime proprietà di scorrimento, maggiore resistenza alla corrosione, durata ed elevata resistenza	AISI 431 (1.4057)
Serie 60 HB	Acciaio inossidabile speciale al cromo-nickel per ottime proprietà di scorrimento, maggiore resistenza alla corrosione, durata ed elevata resistenza	Queste catene dispongono di perni in materiale AISI 431(1.4057)
Serie 66 XHB	Acciaio inossidabile speciale al cromo-nickel per ottime proprietà di scorrimento, maggiore resistenza alla corrosione, durata ed elevata resistenza	Acciaio inossidabile estremamente resistente all'usura
SSC SSR	lega di acciaio inossidabile al nickel-cromo ferritico brevettata OPTI-Plus, per un'elevata resistenza e ottima resistenza all'usura.	AISI 431 (1.4057)
SS 805/815/881	Acciaio Austenitico inossidabile al nickel-cromo con proprietà simili al materiale 18/8, che offre una buona resistenza chimica.	Acciaio inossidabile Austenitico
SS 802/812	Acciaio inossidabile al cromo ferritico, che offre nel contempo una buona resistenza all'usura ed elevata robustezza.	AISI 431 (1.4057)
S SC	Acciaio al carbonio indurito, per il vetro e altre applicazioni asciutte e abrasive, che consente carichi di lavoro estremamente alti e ottima resistenza all'usura.	Acciaio al carbonio indurito
SSB 815	Acciaio Austenitico inossidabile con una resistenza chimica altissima per ambienti corrosivi in cui sono presenti acidi o basi forti. Poiché è praticamente non magnetico, viene utilizzato nelle applicazioni in cui il magnetismo della catena può provocare il cattivo funzionamento del sistema.	Acciaio inossidabile Austenitico
Superficie gommata	Elastomero speciale con una durezza pari a 70 Shore A	
Catene A Tapparella In Plastica		
LF	Acetalica a basso attrito (POM) e miscela speciale di lubrificanti per una minore usura fino al 15% su acetalica normale; destinato alle applicazioni per elevata produttività a velocità medio-alte. Colore: marrone chiaro	Acciaio inossidabile
HP	Elevate prestazioni, acetalica a lubrificazione interna (POM), in grado di ridurre l'usura fino al 40% rispetto all'acetalica standard; studiate per le applicazioni a secco o la lubrificazione ridotta e le applicazioni ad alta velocità. Colore: Braun	
	Poliacetalica lubrificata internamente per applicazioni ad alta velocità, per un'ottima resistenza. Colore: grigio	
BWX	Composto di poliammide per una maggiore resistenza all'usura in condizioni di abrasività fino a cinque volte rispetto all'acetalica standard; da usare nelle applicazioni di movimentazione asciutta del vetro e nei casi in cui la catena è esposta a polvere e sporco. Colore: verde chiaro	
LBP	Resistente all'usura, XLA-acetalica ad attrito bassissimo con additivi autolubrificanti speciali. Colore: antracite I rulli sono in plastica speciale resistente all'usura e fonoassorbente; colore: aubergine. Alberi dei rulli: acciaio inossidabile AISI 304 (1.4301)	
DRY-PT	Lega di polimeri a prestazioni avanzate progettata specificamente per applicazioni con funzionamento a secco. Colore: Verde lime	
SuperGrip	Wear resistant polyester. Colour: anthracite. Rubber top material: special elastomere with a hardness of 70 Shore A. Colour: aubergine	
XLG	Internally lubricated, extra low friction acetal for improved wearlife and high strength; FDA approved. Colour: green-blue	
DKA	Aramide reinforced acetal (POM) for wet or dry abrasive conditions, offering enhanced wear properties over plain acetals in combination with the low friction of a lubricated material. This material is available on request for a selected range of TableTop products.	
MR	Melt resistant nylon PA. Formulated to be used in applications where conveying hot products may cause chain top surface to melt. Colour: black	
CRS	Polyester formulated to reduce or eliminate material degradation in application where chemicals such as chlorine and phosphorous are present at moderate concentrations. Colour: grey	
PLATE TOP CHAINS		
Catena di base Top Plate	Standard: Acciaio al carbonio	
	SS: Acciaio inossidabile	
	Acetalica a basso attrito (POM) e miscela speciale di lubrificanti per ridurre l'usura fino al 15% su acetalica normale. Colore: marrone chiaro	
	Acetalica lubrificato internamente HP (POM), per un'usura ridotta fino al 40% rispetto all'acetalica standard. Colore: grigio	
	Composto di poliammide WX per una maggiore durata in condizioni di abrasività fino a cinque volte superiori rispetto all'acetalica standard. Colore: verde chiaro	
	Policarbonato WPC che offre resistenza al prodotto caduto sulla catena. Colore: bianco	

Prodotto	Materiale del nastro	
Nastri trasportatori modulari in plastica		
AS	Acetalica con proprietà conduttive elettriche migliorate, con riduzione della formazione di elettricità statica. Colore: nero	
WHT*	Polipropilene per applicazioni ad alta temperatura. Colore: bianco. approvato da FDA.	
BHT*	Polipropilene per applicazioni ad alta temperatura. Colore: blu	
BLT*	Polietilene per applicazioni a bassa temperatura; elevata resistenza agli impatti. Colore: blu.	
SMB*	Acetalica per alta pressione ed alta velocità, dovuta alla superficie rigida; buona resistenza all'abrasione. Colore: blu.	
BSM*	Acetalica con resistenza elevata contro usura e danni superficiali. Colore: nero	
BYSM	Acetalica con resistenza elevata contro usura e danni superficiali. Colore: nero con moduli finali gialli.	
HP	Elevate prestazioni, acetalica a lubrificazione interna (POM) in grado di ridurre l'usura fino al 40% rispetto all'acetalica standard; studiate per le applicazioni a secco o a lubrificazione ridotta e per applicazioni ad alta velocità. Colore: Marrone	
HT	Polipropilene per applicazioni con temperature elevate; buona resistenza chimica. Colore: beige	
LF	Acetalica a basso attrito (POM) e miscela speciale di lubrificanti per ridurre l'usura fino al 15% su acetalica standard. Colore: marrone chiaro	
FSX	Acetalica lubrificata internamente per applicazioni ad alta velocità, per un'ottima resistenza. Colore: grigio	
TCF	(Tough Composite Friction), materiale ad elevata resistenza, ottimo impatto e resistenza chimica per trasportatori inclinati in salita o in discesa ad alta velocità. Colore: grigio chiaro	
USP	(Ultra Stabilized Polypropylene), consente di aumentare l'affidabilità e prolungare la resistenza all'usura nelle applicazioni ad elevate temperature, con pastorizzatore chimicamente aggressivo, più caldo e più freddo. Colore: verde	
WLT*	Polietilene per applicazioni a bassa temperatura; elevata resistenza agli impatti. Colore: bianco. approvato da FDA.	
WSM	Acetalica per alta pressione ed alta velocità, dovuta alla superficie rigida; buona resistenza all'abrasione. Colore: bianco.	
BWX	Composto di poliammide per prolungare fino a 5 volte la resistenza all'usura rispetto ai materiali in acetalica; da usare nelle applicazioni per le movimentazioni asciutte di vetro in cui scarti di vetro abrasivi possono logorare rapidamente gli altri materiali; è utilizzabile anche nei casi in cui il nastro viene esposto a polvere e sporcizia. Colore: nero.	
DKA	Acetalica rinforzata con fibre aramidiche idonea per applicazione a secco o bagnate, che offre una migliore resistenza all'usura rispetto all'acetalica standard in combinazione con il basso coefficiente di attrito di un materiale lubrificato. Questo materiale è disponibile a richiesta per una gamma selezionata di prodotti TableTop.	
XLA	Lubrificato internamente, acetalica ad attrito bassissimo per una maggiore resistenza all'usura e resistenza elevata. Colore: antracite	
XLG	Lubrificato internamente, acetalica ad attrito bassissimo per una maggiore resistenza all'usura e resistenza elevata; munito di approvazione FDA. Colore: verde-blu	
XP	Polipropilene resistente all'usura con ottima stabilità al calore a lungo termine – fino a 104°C – e un'ottima resistenza chimica; approvato dall'FDA. Colore: verde chiaro	
Dry-PT	Materiali anti-statici e resistenti alle sostanze chimiche possono essere forniti per un numero di catene limitato. Per maggiori dettagli, chiedere al Servizio Clienti	
CRS	Poliestere formulato per ridurre la degradazione del materiale dove agenti chimici come cloro e fosforo sono presenti in moderate concentrazioni. Colore: grigio	
DTS-C Trasferimento	Poliammide rinforzato super rigido; resistenza all'usura e all'abrasione, resistenza ultra elevata. Colore: nero	
Trasferimento aste 2500	Blocco di montaggio: MCC 1001; miscela e grado elevato di UHMWPE. Colore: nero Perni: Polipropilene BPR rinforzato. Colore: verde-blu	
Piastre ad aste profilo 1000/2000	Acciaio inossidabile AISI 304	
HTX	L'HTX è un polimero di ultimissima tecnologia sviluppato specificamente per tunnel di termoretrazione. Colore: Grigio	
FRPLUS	Ritardante di fiamma a basso attrito (argento metallico)	
FR-PA	Poliammide ritardante di fiamma	
Catene multiflex e catene trasporto casse		
HP	Acetalica lubrificata internamente ad alte prestazioni (POM) per un'usura ridotta fino al 40% rispetto all'acetalica standard. Colore: marrone	Acciaio inossidabile
LF	Acetalica a basso attrito (POM) e miscela speciale di lubrificanti per ridurre l'usura fino al 15% su acetalica standard. Colore: marrone chiaro	Acciaio inossidabile 1700 K: acciaio inossidabile zincato
WLF	Acetalica a basso attrito (POM) e miscela speciale di lubrificanti per ridurre l'usura fino al 15% su acetalica normale. Colore: bianco	Acciaio inossidabile 1700 K: zinc plated stainless steel
AC	Acetalica Armor Clad con piastre in acciaio indurito	Zinc plated
BWX	Composto di poliammide WX per una maggiore durata in condizioni di abrasività fino a cinque volte superiori rispetto all'acetalica standard. Colore: nero	Acciaio inossidabile 1700 K: zinc plated stainless steel
Ruota di curvatura Mozzo	Poliammide rinforzato Acetalica a basso attrito HP (ND 1700 FL/TR): ottone (880)	
BL	Acetalica. Colore: blu, RAL 5005	AISI 301 (1.4310)
WPP	Polipropilene resistente ai prodotti chimici e all'acqua ad alta temperatura con fibre di vetro. Colore: bianco	

* Comply with the relevant requirements as laid down in: Framework Regulation (EC) 1935/2004 (dated 27-10-2004). EU Commission Regulation (EU) 10/2011 relating to plastic materials (tested according to EC Directive 97/48/EC; Migration testing (2nd amendment of 82/711/EEC) and EC Directive 85/572/EC; List of simulants).

Parte	Materiali
Curve	
Curve Combi-X	Le curve Combi-X sono realizzate con una struttura ibrida utilizzando una base in plastica rigida e speciali inserti ram-estrusi in ULF (ultra low-friction) in polietilene con speciali lubrificanti solidi. Questa costruzione permette minore attrito maggiore durata di curve e catene con minore consumo di energia e minori costi di manutenzione. Il disegno è Patent Pending.
Parte superiore delle curve Combi-A e CIP	MCC 1200, polietilene a peso molecolare ultra elevato, per una resistenza ottimale all'usura e all'abrasione. Colore: aubergine.
Parte superiore delle curve Combi-S	MCC 3500, poliammide speciale per una resistenza ottimale all'abrasione nelle linee a secco, in cui le catene di plastica scorrono a velocità elevata. Colore: grigio solfito
Parte superiore delle curve Combi-L	MCC 3000, polietilene a peso molecolare ultra elevato, per la riduzione del rumore e limiti PV elevati. Colore: blu chiaro
Tutte le parti di ritorno	MCC 1002, miscela di grado elevato di polietilene a peso molecolare ultra elevato, per una buona resistenza all'usura e all'abrasione. Colore: nero
Piastre di copertura	Acciaio inossidabile AISI 430 (1.4016)
Viti	Acciaio inossidabile
Inserti (opzionali)	Ottone
Pattino	MCC 1200, polietilene a peso molecolare ultra elevato, per una buona resistenza all'usura e all'abrasione
Tubi nelle curve CIP	Acciaio inossidabile AISI 303 (1.4305) Colore: nero
Ugelli nelle curve CIP	Acciaio inossidabile AISI 303 (1.4305)
Curve TAB - Inserti (opzionali)	MCC 1003, polietilene a peso molecolare ultra elevato, per una buona resistenza all'usura e all'abrasione
Parte superiore delle curve Combi-G	MCC 2000, polietilene a peso molecolare ultra elevato, con additivi in ceramica appositamente integrati; per un'elevata resistenza all'abrasione. Colore: verde-giallo.

Ruota di traino	Materiali
Ruote di traino e di rinvio per catene a piastre	
N/NS/NSH	Poliammide rinforzato super rigido; resistenza all'usura e all'abrasione
KU(S)/KT/NS(T)/N(T)/SD	Poliammide
ST	Acciaio al carbonio
Bolts	Acciaio inossidabile AISI 304 (1.4301)
Inserts	Ottone
Ruote di traino e di rinvio per catene Multiflex	
KU/KUS/N/NT	Poliammide
ZN	Zincato
CI	Ghisa
Ruote di traino per catene trasporto casse	
KU	Poliammide
SR	Poliammide rinforzato super rigido; resistenza all'usura e all'abrasione
Hub	Acciaio al carbonio con finiture nere o acciaio inossidabile
Ruote di traino per nastri modulari	
NS 500/1000/ NSH1500/1005 NS 1500/5996/5700/7700/8500/7956 N 1500 NS 2500 RPA	Poliammide rinforzato; resistenza ultra elevata, resistente all'usura e all'abrasione
KU/KUS 500/1000/505/1255 KU 1500/3125/5936/7700/8500/7956 KUS 1500/7700/3125	Poliammide, super resistente, resistente all'usura e all'abrasione
KUS 1005/505/1255	Plastica speciale; super resistente, resistente all'usura e all'abrasione
KU 1010 KU 2010	Polietilene
N 5996/4700/5936 N/NS 2000	Acetalica; resistente all'usura POM Acetalica; resistente all'usura
Bolts and nuts	Acciaio inossidabile AISI 304 (1.4301)
Inserts	Ottone

Catena	Pagina	Nastro	Pagina	Ruota di traino	Pagina	Ruota di traino	Pagina
10 M	16	390	132	CH CC	88	ZN1700	81
10 S	10	500 FG	135	N 500	135	KU 1775	81
10 T	18	500 FGP	135	KUS 505	215	KUS 1775	82
60 M	16, 19	505 RBP	214	KU 1255	216	KUS 1785	82
60 S	10, 11, 12, 14	590		N 2000	192		
66 M	16, 19, 24, 25	136		KU 2010	196	Curve/straight track	pagina
66 S	11, 12, 21, 22, 23	905 Nosebar		CI 1757	82		
66 ST	23	1000 CLICK-COMB	145	KU 600	88	505 TAB CURVE	215
66 T	25	1000 FFGP	158	KU 815	55	1200 TAB CURVE	220
512	14	1000 FFTP	157	KU 821	61	C1	103
661 S	15	1000 FG	158	KU 1010	173	C2	103
661 M	20	1000 FGDP	158	KU 1500	146	C3	104
800/802/805	12	1000 FINGER	160	KU 3120	212	C4	104
810	14	1000 FT	157	KU 5936	185	C5A	105
812 TAB	13, 21	1000 FTDP	157	KU 7700	185	C5C	105
815	11	1000 LBP	162	KU 7956	222	C6/CX6	106
815 TAB	13	1000 RR	160, 161	KU 8500	150	C7/CX7	107
820	28	1000 RRR	161	KUS 815	54	C14	108
820 RT	40	1000 SG	159	KUS 821	62	C21A	109
820 Vacuum	38	1000 SGDP	159	KUS 661	64	C22A	109
821	30	1005 FFTP	165	KUS 1500	146	C42	110
821 RT	40	1005 FT	165	KUS 2500	82	C43	110
831	29	1005 FTDP	165	KUS 3120	212	C61/C6T	111
843	92	1005 XLBP	168	KUS 7700	185	C65	112
879	33	1005 SG	166	KT 800	62	C66	112
879 TAB	35	1005 SGDP	166	N 800	60	C81	113
879 TAB BO	36	1005 SGS	166	N 820	56	C86	113
879 BO RT	46	1005 SGSDP	167	N 1108	70	C91	114
879 TAB BO LBP	48	1015	165	NSH 880	65	C96	114
880	32	1255 RB	216	N 5936	154	CB6/CXB6	117
880 TAB	34, 38	1255 RBP	216	N 5996	199	CC6/CXC6	118
880 TAB BO	36, 39	1255 SG	216	NS 815	53	CC21	119
880 TAB BO RT	44	1265 RBT	217	NS 820	56	CF6	108
880 TAB RT	43	1275 RB	218	NS 821	60	CIP4	105
880 TAB Vacuum	38	1285 RBT	204	NS 831	65	KSU	124
881	16, 17	1505	141	NS 880	69	KSU 200	125
881 TAB	17	1505 DTS	141	NS 881	59	KTU	120
882 TAB	37	1505 FT	143	NS 882	68	KTU 200	121
883 TAB LBP	48	1505 FTDP	143	NS 1500	146	KTU 300	122
963	91	1505 SG	144	NSH 815	53	KTU 500	123
1055 FT/FTM	51, 52	1505 SGDP	144	NSH 820/831	65	LBP2	115
1060 FTM	51	1505 SGS	144	NSH 880	67	LBP91	116
1700	77	1505 SGSDP	144	NSH 1005	169	LBP96	116
1720	78	1506	142	NSH1500	146	LBP861	115
1757	76	2000 CLICK-COMB	191	NS 5936	154	N 880 BO	71
1765 ZeroGap	74	2000 DTS-C	192	NS 5996	199	ND 1700	83
1775 ZeroGap	74	2000 FG	188	NS 7700	185	ND 1700BC	83
1843 TAB	92, 96	2000 FT	188	NS 7956	222	ND 1700BO	83
1864	91	2000 RR	189	NS 8500	150	ND 1700FL	83
1873 TAB	94, 97, 98	2000 RRHD	189	NS 821	60, 67	NX 880 BO	71
1873 TAB SG	95	2000 RRHDP	189	NS 880	69	NXT 880 BO	71
1874	93	2000 RRP	189	NS 881	59	STU	126
2565	75	2000 SR	190	NS 882	68	SSU	127
2755 BSM	87	2011	195	NST 820	57	D384 PA	83
3873 TAB	95	2015	194	N 800	60		
8811 TAB	18, 25	2016	194	N 881	59		
CC 600	84	3125/3129	207	N 1108	70		
CC 631 TAB	85	3125RT	208	N 1700	81		
CC 1400	85	3180	208	NT 820	57		
CC 1431 TAB	86	5935	152	NS 821	67		
HDF LBP	51	5935 Vacuum	153	NT 1757	82		
HDFM	32	5936	152	KU 75	58		
HDFM LBP	49	6995	198	KU RH	67		
HDFM SG	42	6999	198	KUS 75	58		
HDS	30	7705	182	KUS 1005	169		
HDS LBP	46	7705 DTS	182	KUS 882	68		
HDS SG	44	7706	184	KUS 880	69		
RH/RHD	34, 35	7708	184	NS 1050	70		
RHM/RHMD	31	7956	221	SR CC 600/1400	88		
RHMD LBP	47	8505	148	KUS 75	58		
RHMP/RHMDP	31	8505 DTS	148	KUS 505	215		
SH/SHD/SHP	28, 29	8506	149	KUS 661	64		
SHD LBP	45	6995 Hybrid H4	200	KUS 1005	169		
SWH	30	6999 Hybrid H4	200	KUS 1255	220		
SWH LBP	46	6995 Hybrid H8	201	NS 2000	192		
SWH SG	41	6999 Hybrid H8	201	KUS 882	68		
				KUS MINI	62		
				KUS 880	69		
				KUS 820	66		
				NS 500	135		
				NS 1000	163		
				NS 1050	70		
				KUS 2755	88		

Perché scegliere Rexnord?

In quanto a prodotti ad alto contenuto ingegneristico che migliorino la produttività e l'efficienza, Rexnord è l'azienda più affidabile nel mondo dell'industria. L'impegno a soddisfare i clienti e il valore superiore dei nostri prodotti si estendono trasversalmente a ogni ramo aziendale.

Prodotti forniti a minimi costi totali di proprietà (TCO)

I nostri prodotti, di altissima qualità, sono destinati a prevenire i tempi di fermo nonché a migliorare la produttività e a determinare un'operatività affidabile.

Una competenza che vale

La vasta offerta di prodotti è supportata dalla consulenza di specialisti di vendita a livello mondiale nonché dai team addetti all'assistenza clienti e alla manutenzione, disponibili in qualsiasi momento.

Soluzioni che facilitano il business

L'impegno a operare in modo eccellente assicura la fornitura dei prodotti giusti al posto giusto e al momento giusto.

REXNORD

Rexnord Corporation

Rexnord è un'azienda orientata alla crescita leader nelle quote di mercato e ha brand affermati di grande credibilità che servono una molteplice gamma di consumatori finali globali.

Process & Motion Control

I progetti del comparto Rexnord che fornisce sistemi di movimentazione e dispositivi di controllo di processo: manufatti, richieste e servizi forniti su diretta specifica del cliente, componenti meccanici a elevato contenuto ingegneristico [Country]ti all'interno di complessi sistemi in cui i requisiti di affidabilità richiesti dalla clientela e i costi dei guasti nonché dei tempi di fermo sono estremamente elevati.

Water Management

Il comparto Rexnord per la gestione delle acque: progetti, sistemi di approvvigionamento, manufatti e prodotti di mercato che garantiscono e migliorano la qualità dell'acqua nonché ne controllano il flusso e la conservazione.